

PROFESSIONAL CAKE DESIGN 2025

Crea
**Special
Moments**



con

deKora

Special moments

dekora.es





DISCOS Y PLACASDiscs and plaques · Disques et plaques · Discos e placas · Dischi e placche **3****Discos y placas comestibles**Edible discs and plaques · Disques et plaques comestibles · Discos e placas comestíveis · Dischi e placche commestibili **4****Discos y placas de oblea**Wafer discs and plaques · Disques et plaques en azyme · Discos e placas de obreia · Dischi e placche in cialda **29****OBLEA**Wafer · Azyme · Obreia · Cialda **57****AZÚCAR**Sugar · Sucre · Açucar · Zucchero **83****TOPPING**Topping decoration · Décoration topping · Decoração topping Decorazione topping **113****CHOCOLATE**Chocolate decoration · Décoration chocolat Decoração chocolate Cioccolato **123****MATERIA PRIMA Y TEXTURIZANTES**Raw materials and texturizers · Matière première et épaississants · Matéria prima e texturas · Materia prima e testurizzanti **153****COLORANTES**Colourings · Colorants · Colorantes · Coloranti **177****DECORACIÓN NO COMESTIBLE**Non edible decoration · Décoration non comestible · Decoração não comestível · Decorazione non commestibile **199****CAKE TOPPERS****229****VELAS + BENGALAS**Candles + Sparkles · Bougies + Bougies fontaines · Velas + foguetes · Candele + Bengala **245****EVENTOS**Events · Évènements · Eventos · Eventi **289****Boda**Weddings · Mariage · Boda · Nozze **290****Bautizo**Christening · Baptême · Baptizado · Battesimo **312****Comunión**Holy Communion · Communion · Comunhão · Comunione **323****UTILLAJE**Tools · Outillage · Utensílios · Utensili **333**

**¡Un cambio
de Packaging
está en el
horno!**

Estos nuevos diseños llegarán gradualmente a lo largo del año.

EN/ A new packaging is in the oven! These new designs will roll out gradually throughout the year. **FR/** Un changement de packaging est au four! Ces nouveaux designs arriveront progressivement tout au long de l'année. **PT/** Uma mudança de embalagem está no forno! Esses novos designs chegarão gradualmente ao longo do ano. **IT/** Un cambiamento di packaging è in forno! Questi nuovi design arriveranno gradualmente nel corso dell'anno.



Nuestros indicadores

Our indicators / Nos indicateurs / Nossos indicadores / I nostri indicatori



Sin gluten · Gluten free · Sans gluten
Sem glúten · Senza glutine.



Colorantes naturales · Natural colors
Colorants naturels · Corantes naturais
Coloranti naturali.



Aroma y color natural
Natural flavour - natural colour
Arôme naturel - couleur naturelle
Aroma natural - cor natural
Aroma naturale - colore naturale



Producto apto para vegetarianos
Product suitable for vegetarians
Produit adapté aux végétariens
Produto adequado para vegetarianos
Prodotto adatto ai vegetariani



Sin proteínas de la leche
Without milk proteins
Sans protéines de lait
Sem proteínas do leite
Senza proteine del latte



Sin lactosa · Lactose free · Sans
lactose · Sem lactose · Senza lattosio



Incluye receta · Includes recipe
Inclut la recette · Inclui receita
Include la ricetta



Sin azúcares añadidos
No added sugar
Sans sucre ajouté
Sem adição de açúcar
Senza zuccheri aggiunti



Producto que incluye Vídeo · Product
that includes Video · Produit qui inclut
la vidéo · Produto que inclui Vídeo
Prodotto che include Vídeo



Producto reutilizable · Product
reusable · Produit réutilisable
Produto reutilizável · Prodotto
riutilizzabile



Chocolate 100%
Chocolat 100%
Cioccolato 100%



AZO Free



Moldes magnéticos · Magnetic moulds
Moules magnétiques · Moldes
magnéticos · Stampi magnetici



Sin colorantes azoicos · Free of azo
dyes · Sans colorants azoïques · Sem
corantes azóicos · Senza coloranti
azoici



Producto apto para la venta retail
Product suitable for retail sale
Produit adapté à la vente au détail
Produto apto para venda por retail
Prodotto idoneo alla vendita retail



Apto para contacto alimentario
Suitable for food contact
Adapté au contact alimentaire
Adequado para contato alimentar
Idoneo al contatto con alimenti



Producto Halal · Halal product
Produit Halal · Produto Halal
Prodotto Halal



Producto Kosher · Kosher product
Produit Casher · Produto Kosher
Prodotto Kosher



La mayoría de nuestras figuras
contienen envasado individual.
Most of our figures come individually
packaged.



La plupart de nos figures sont
emballées individuellement.



A maioria das nossas figuras são
embaladas individualmente.

La maggior parte delle nostre figure
prevedono imballaggio individuale.



Discos y Placas comestibles

Edible discs and plaques

Disques et plaques

Discos e placas comestíveis

Dischi e placche commestibili



deKora

Special Moments

PAPEL COMESTIBLE

Edible paper · Papier comestible · Papel comestível · Carta edibile

Todos nuestros discos comestibles, mini discos y recortables son fabricados sin azúcar.

All our edible discs, mini discs and cut-outs are made sugar free.

Tous nos disques, mini disques et découpables sont fabriqués sans sucre.

Todos os nossos discos, mini discos e recortáveis são fabricados sem açúcar.

I nostri dischi edibili da 16 cm, mini dischi e tagliabili non contengono zucchero.

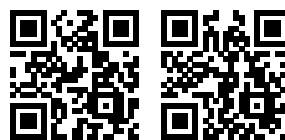

Ø 20 cm



236018
UNICORNIO



236044
PEPPA PIG



236008
FROZEN



236037
DISNEY PRINCESS



231272
MICKEY



236039
EL REY LEÓN



NEW **236117**
STITCH



236017
PAW PATROL



236028
DINOSAURIO



236038
AVENGERS



NEW **236098**
SPIDERMAN



236040
SPIDER-MAN



231137
FÚTBOL

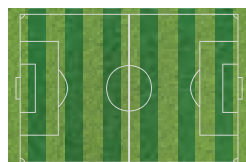

231136
FÚTBOL

Ø 16 cm



231360
UNICORNIO



231367
DINOSAUR



231365
AVENGERS

Ø 15,5



231388
PRINCESAS



231408
FROZEN

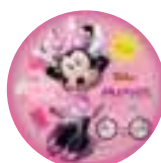

231389
MINNIE



231390
PEPPA PIG



231394
PAW PATROL



231393
SPIDER-MAN

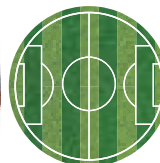

NEW **231414**
FOOTBALL



231410
FOOTBALL

PAPEL COMESTIBLE

Edible paper · Papier comestible · Papel comestível · Carta edibile

ø 5,8 cm



236033
PEPPA PIG



236049
MICKEY Y MINNIE



236032
PAW PATROL

ø 3,4 cm



231400
PAW PATROL



231401
TESIA & FRIENDS



231402
DINOSAURIOS



NEW **231412**
STITCH

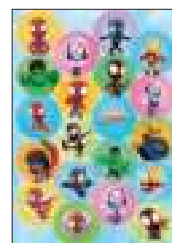

NEW **231413**
SPIDEY

Recortables

Cuts-outs - Découpables - Recottáveis - Carta edibile



231399
PEPPA PIG



231395
PAW PATROL



231397
AVENGERS



231398
SPIDER-MAN



231396
FROZEN

Rectangular 21 x 14,85 cm

Rectangular - Rectangulaire - Retangular - Rettangolare



NEW **236118**
STITCH



236063
PAW PATROL



236084
DISNEY PRINCESS

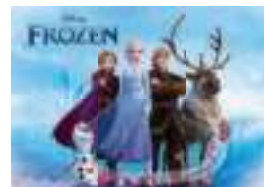

236054
FROZEN



236076
SPIDERMAN



NEW **236128**
DRAGON BALL

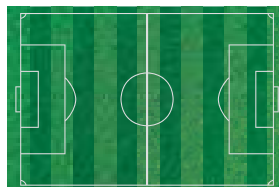

NEW **236120**
FÚTBOL



NEW **236119**
LGTBI

PAPEL COMESTIBLE



Edible paper · Papier comestible · Papel comestível · Carta edibile

Ø 20 cm

236018

UNICORNIO



Unicorn - Licorne - Unicórnio

Ø 20 cm ·  x 6 



236044

PEPPA PIG

Ø 20 cm ·  x 6 





PAPEL COMESTIBLE

Edible paper · Papier comestible · Papel comestível · Carta edibile

236008



FROZEN ZERO

Ø 20 cm ·  x 6 



236037

PRINCESAS DISNEY

Ø 20 cm ·  x 6 





PAPEL COMESTIBLE

Edible paper · Papier comestible · Papel comestível · Carta edibile

231272



MICKEY

Ø 20 cm ·  x 6 



236039

EL REY LEÓN

Ø 20 cm ·  x 6 





PAPEL COMESTIBLE

Edible paper · Papier comestible · Papel comestível · Carta edibile

NEW

236117



STITCH

Ø 20 cm ·  x 6 



236017

PAW PATROL

Ø 20 cm ·  x 6 



PAPEL COMESTIBLE

Edible paper · Papier comestible · Papel comestível · Carta edibile

236028

DINOSAURIO

Dinosaur - Dinsaure

Dinosaurio

Ø 20 cm ·  x 6



236038

AVENGERS

Ø 20 cm ·  x 6





PAPEL COMESTIBLE

Edible paper · Papier comestible · Papel comestível · Carta edibile

NEW

236098



SPIDERMAN

Ø 20 cm ·  x 6 



236040

SPIDER-MAN

Ø 20 cm ·  x 6 



PAPEL COMESTIBLE

Edible paper · Papier comestible · Papel comestível · Carta edibile

231137

FÚTBOL

Football - Futebol

Ø 20 cm ·  x 6



231136

FÚTBOL

Football - Futebol

20 x 30 cm ·  x 6

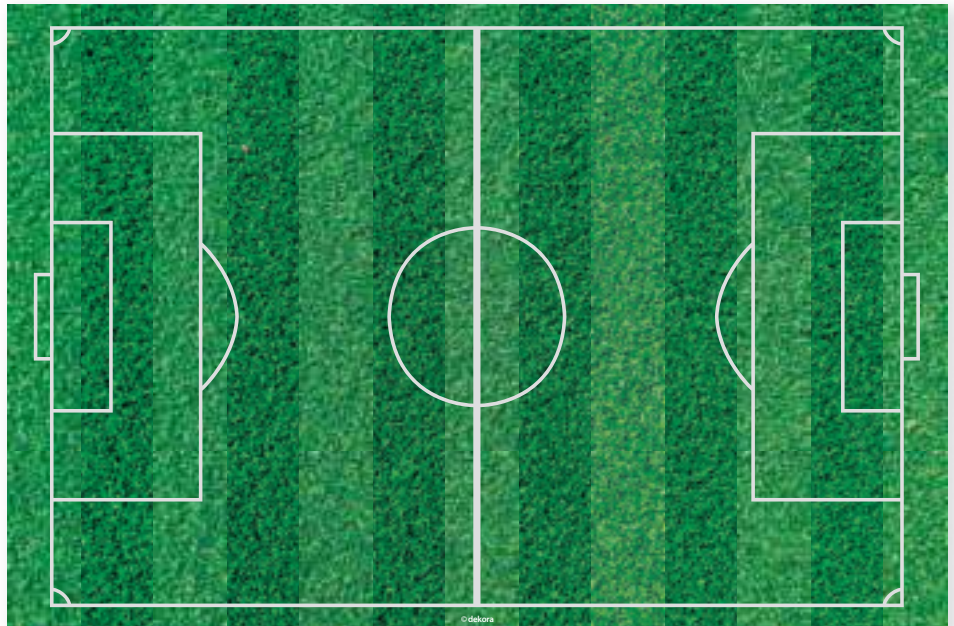

PAPEL COMESTIBLE

Edible paper · Papier comestible · Papel comestível · Carta edibile

Ø 16 cm



231360
UNICORN
15 g · Ø 16 cm
x 10



231367
DINOSAUR
15 g · Ø 16 cm
x 10



231365
AVENGERS
15 g · Ø 16 cm
x 10



PAPEL COMESTIBLE

Edible paper · Papier comestible · Papel comestível · Carta edibile

Ø 15,5 cm



231388
PRINCESAS
14 g · Ø 15,5 cm
x 10



231408
FROZEN
14 g · Ø 15,5 cm
x 10



231389
MINNIE
14 g · Ø 15,5 cm
x 10



PAPEL COMESTIBLE

Edible paper · Papier comestible · Papel comestível · Carta edibile



231390
PEPPA PIG
14 g · Ø 15,5 cm
x 10



231394
PAW PATROL
14 g · Ø 15,5 cm
x 10



PAPEL COMESTIBLE

Edible paper · Papier comestible · Papel comestível · Carta edibile



231393
SPIDER-MAN
14 g · Ø 15,5 cm
x 10



PAPEL COMESTIBLE



Edible paper · Papier comestible · Papel comestível · Carta edibile

NEW

231414

FÚTBOL

14 g · Ø 15,5 cm



 x 10 



231410

FÚTBOL ZERO

14 g · Ø 15,5 cm

 x 10 



PAPEL COMESTIBLE

Edible paper · Papier comestible · Papel comestível · Carta edibile

Mini discos COMESTIBLES 5,8 cm.

Mini edible discs - Mini disques comestible - Mini discos comestíveis - Mini dischi edibili



236033
PEPPA PIG

Ø 5,8 cm ·  x 6  x 6 





TROQUELADOS – DIE CUTS
– DÉCOUPE



EN: How to use?
FR: Comment
l'utiliser?
PT: Como utilizar?
IT: Come si usa?



236049
MICKEY & MINNIE

Ø 5,8 cm
 x 6  x 6 



TROQUELADOS – DIE CUTS
– DÉCOUPE



PAPEL COMESTIBLE

Edible paper · Papier comestible · Papel comestível · Carta edibile



236032

PAW PATROL

Ø 5,8 cm ·  x 6  x 6 



TROQUELADOS - DIE CUTS
- DÉCOUPE



Mini discos COMESTIBLES 3,4 cm.

Mini edible discs - Mini disques comestible - Mini discos comestíveis

Mini dischi edibili



231400

PAW PATROL

Ø 3,4 cm

 x 6  x 20 



PAPEL COMESTIBLE

Edible paper · Papier comestible · Papel comestível · Carta edibile



231401

TESIA & FRIENDS

Ø 3,4 cm ·  x 6  x 20 



231402

DINOSAURIOS

Ø 3,4 cm ·  x 6  x 20 



PAPEL COMESTIBLE

Edible paper · Papier comestible · Papel comestível · Carta edibile



NEW

231412
STITCH

Ø 3,4 cm ·  x 6  x 20 



NEW

231413
SPIDEY

Ø 3,4 cm ·  x 6  x 20 



Recortables

Cuts-outs - Découpables - Recottáveis - Carta edibile



231399
PEPPA PIG
 14,8 x 21 cm
 ☞ x 6 ☞ x 13 u.



231395
PAW PATROL
 14,8 x 21 cm
 ☞ x 6 ☞ x 15 u.



PAPEL COMESTIBLE

Edible paper · Papier comestible · Papel comestível · Carta edibile



231397
AVENGERS
14,8 x 21 cm
📦 x 6 📄 x 13 u.



231398
SPIDER-MAN
14,8 x 21 cm
📦 x 6 📄 x 12 u.



EN: How to use?
FR: Comment l'utiliser?
PT: Como utilizar?
IT: Come si usa?

PAPEL COMESTIBLE

Edible paper · Papier comestible · Papel comestível · Carta edibile



231396
FROZEN

14,8 x 21 cm ·  x 6  x 12 u.



PAPEL COMESTIBLE

Edible paper · Papier comestible · Papel comestível · Carta edibile

Rectangular

Rectangular - Rectangulaire - Retangular - Rettangolare

NEW



236118
STITCH

14,8 x 21 cm · x 6



236063
PAW PATROL



14,8 x 21 cm · x 6



PAPEL COMESTIBLE

Edible paper · Papier comestible · Papel comestível · Carta edibile



236084
DISNEY PRINCESS
14,8 x 21 cm ·  x 6 



236054
FROZEN
14,8 x 21 cm ·  x 6 





PAPEL COMESTIBLE

Edible paper · Papier comestible · Papel comestível · Carta edibile



236076
SPIDERMAN

14,8 x 21 cm ·  x 6 



236128
DRAGON BALL

14,8 x 21 cm ·  x 6 



PAPEL COMESTIBLE

Edible paper · Papier comestible · Papel comestível · Carta edibile

NEW

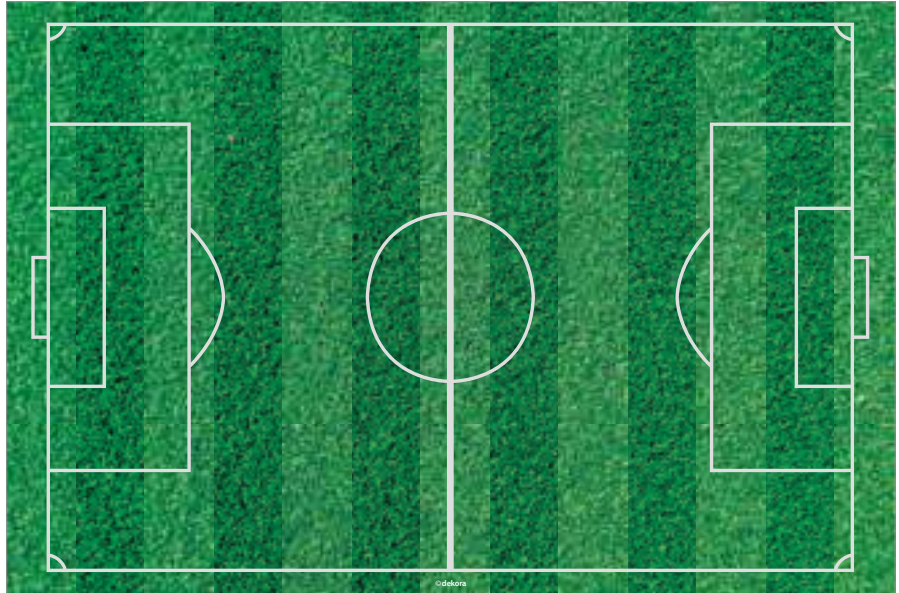

236120

FÚTBOL

Football - Futebol

14,8 x 21 cm ·  x 6



NEW



236119

LGTBI

14,8 x 21 cm ·  x 6



Discos y Placas de oblea

Wafer discs and plaques

Disques et plaques en azyme

Discos e placas de obreia

Dischi e placche in cialda



deKora

Special moments

Ø 20 cm

Wafer discs + Foil - Disques azyme + Foil - Discos obreia + Foil



160174
MY LITTLE PONY



145099
SIRENITA



145096
UNICORNIO



145086
UNICORNIO



160163
PAW PATROL



160131
PEPPA PIG



114371
MINNIE



114381
MINNIE



114382
FROZEN



114383
FROZEN



114366
FROZEN



114377
PRINCESAS

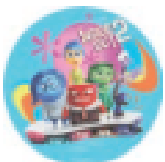

114450
INSIDE OUT 2



114453
VAIANA 2



114437
STITCH



114440
SPIDEY



160117
PAW PATROL



160129
PAW PATROL

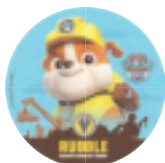

160195
RUBBLE



114370
CARS III



114378
MICKEY



160132
PJ MASKS

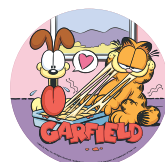

160194
GARFIELD



145093
DINOSAURIO



114402
AVENGERS



114401
AVENGERS



160156
TORTUGAS NINJA



160160
BOB ESPONJA



114398
SPIDER-MAN



114367
SPIDER-MAN



114436
VENOM



160137
JUSTICE LEAGUE



160205
SONIC



160206
DRAGON BALL



145114
FÚTBOL



145094
FÚTBOL



145136
BALONCESTO

OBLEA

Wafer · Azyme · Obreia · Cialda

Ø 3,4 cm



145102

MINI BALONES FÚTBOL

Siluetas de oblea

Wafer silhouette - Silhouette de azyme - Silhueta obreia - Sagome in cialda

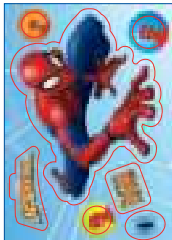

114427
SPIDERMAN

NEW

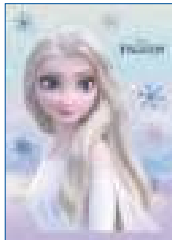

114412
FROZEN



160182
PEPPA PIG

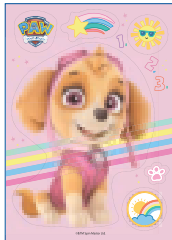

160181
PAW PATROL
SKYE



160167
PAW PATROL
CHASE

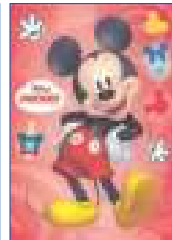

114418
MICKEY



114419
MINNIE

Dekorapin de oblea

Wafer Dekorapin - Dekorapin azyme - Dekorapin obreia - Dekorapin cialda



135044
DC

NEW



135017
SPIDER-MAN



135050
PEPPA PIG



135021
PATRULLA CANINA



135013
FROZEN



OBLEA

Wafer · Azyme · Obreia · Cialda

Ø 20 cm

160174



MY LITTLE PONY

Ø 20 cm ·  x 6 



145099

SIRENITA



Ø 20 cm ·  x 6 



145096

UNICORNIO

Unicornio - Licorne - Unicórnio



Ø 20 cm ·  x 6 



145086

UNICORNIO



Unicornio - Licorne - Unicórnio

Ø 20 cm ·  x 6 



160163



PAW PATROL

Ø 20 cm ·  x 6 



160131



PEPPA PIG

Ø 20 cm ·  x 6 



114371



MINNIE

Ø 20 cm ·  x 6 



114381

MINNIE



Ø 20 cm ·  x 6 



OBLEA



Wafer · Azyme · Obreia · Cialda

114382
FROZEN

Ø 20 cm ·  x 6 





114383
FROZEN

Ø 20 cm ·  x 6 





114366
FROZEN

Ø 20 cm ·  x 6 



114377
PRINCESAS

Ø 20 cm ·  x 6 





OBLEA

Wafer · Azyme · Obreia · Cialda

NEW

114450

INSIDE OUT 2



Ø 20 cm ·  x 6 



NEW

114453



VAIANA 2

Ø 20 cm ·  x 6 



NEW



114437
STITCH

Ø 20 cm ·  x 6 



NEW



114440
SPIDEY

Ø 20 cm ·  x 6 



160117



PAW PATROL

Ø 20 cm ·  x 6 



160129



PAW PATROL

Ø 20 cm ·  x 6 





NEW

160195
RUBBLE

Ø 20 cm ·  x 6 



114370
CARS 3

Ø 20 cm ·  x 6 





OBLEA

Wafer · Azyme · Obreia · Cialda

114378



MICKEY

Ø 20 cm ·  x 6 



160132

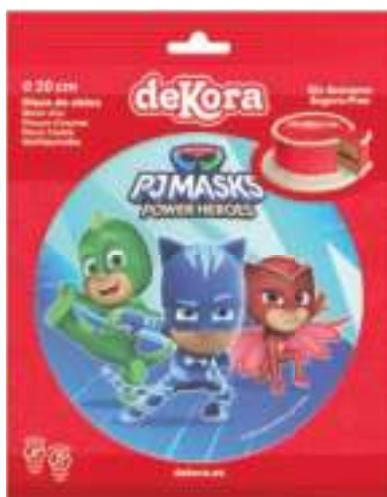

PJ MASKS

Ø 20 cm ·  x 6 



NEW

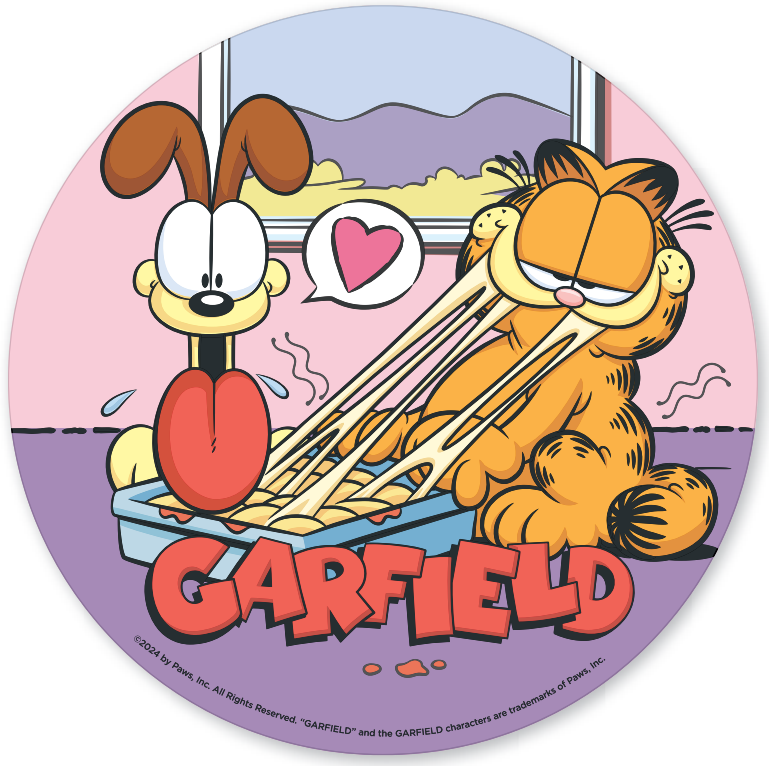

160194
GARFIELD

Ø 20 cm ·  x 6 





145093
DINOSAURIO

Dinosaur - Dinosaur - Dinosauro - Dinosaurio

Ø 20 cm ·  x 6 





114402
AVENGERS

Ø 20 cm ·  x 6 





114401
AVENGERS

Ø 20 cm ·  x 6 



160156



TORTUGAS NINJA

Ø 20 cm ·  x 6 



160160



BOB ESPONJA

Ø 20 cm ·  x 6 



114398



SPIDER-MAN

Ø 20 cm ·  x 6 



114367

SPIDER-MAN

Ø 20 cm ·  x 6 





21 cm

26,3 cm





NEW

114436
VENOM

Ø 20 cm ·  x 6 



160137
JUSTICE LEAGUE

Ø 20 cm ·  x 6 





OBLEA

Wafer · Azyme · Obreia · Cialda

NEW

160205

SONIC



Ø 20 cm ·  x 6 



NEW

160206

DRAGON BALL



Ø 20 cm ·  x 6 



145114

FÚTBOL

Footbal - Futebol



Ø 20 cm ·  x 6 



145094

FÚTBOL

Footbal - Futebol

Ø 20 cm ·  x 6 





OBLEA

Wafer · Azyme · Obreia · Cialda

NEW

145136

Baloncesto
Basketball

Ø 20 cm ·  x 6 



Mini discos de oblea 3,4 cm

Wafer mini edible discs - Mini disques de azyme - Mini discos obreia
Mini dischi in cialda



145102

MINI BALONES FÚTBOL

Troqueladas - Pre-cut

Pré-découpées - Sagomati

Ø 3,4 cm ·  x 6  x 20 

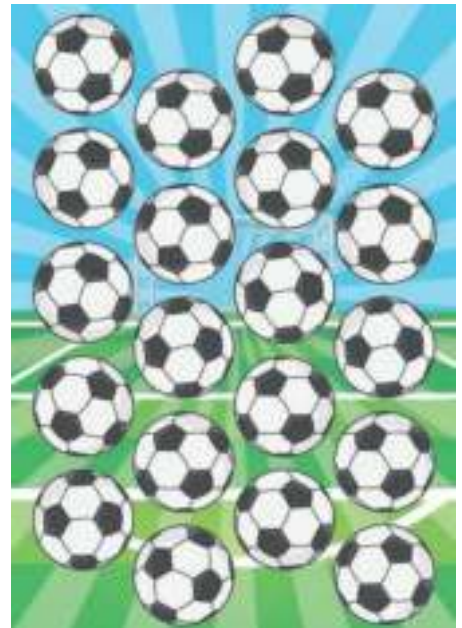

OBLEA

Wafer · Azyme · Obreia · Cialda

Siluetas de oblea

Wafer silhouette - Silhouette de azyme - Silhueta obreia - Sagome in cialda



EN: How to use? FR: Comment l'utiliser?
PT: Como utilizar? IT: Come si usa?





NEW

114427

SPIDERMAN

Troqueladas - Pre-cut

Pré-découpées - Sagomati

14,8 X 21 cm ·  x 6 





114412
FROZEN
 Troqueladas - Pre-cut
 Pré-découpées - Sagomati
 14,8 x 21 cm · x 6

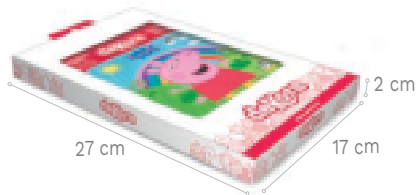

160182
PEPPA PIG
 Troqueladas - Pre-cut
 Pré-découpées - Sagomati
 14,8 X 21 cm · x 6







160181
PAW PATROL - SKYE
 Troqueladas - Pre-cut
 Pré-découpées - Sagomati
 14,8 x 21 cm · x 6





160167
PAW PATROL - CHASE
 Troqueladas - Pre-cut
 Pré-découpées - Sagomati
 14,8 x 21 cm · x 6





114418
MICKEY
 Troqueladas - Pre-cut
 Pré-découpées - Sagomati
 14,8 x 21 cm ·  x 6 



114419
MINNIE
 Troqueladas - Pre-cut
 Pré-découpées - Sagomati
 14,8 x 21 cm ·  x 6 



OBLEA

Wafer · Azyme · Obreia · Cialda

Dekorapin de oblea

Wafer Dekorapin - Dekorapin azyme - Dekorapin obreia - Dekorapin cialda



135044

DC



Troqueladas - Pre-cut

Pré-découpées - Sagomati

6,5 x 4 cm

6 x 6 x 2 x 10



YouTube

EN: How to use?

FR: Comment

l'utiliser?

PT: Como utilizar?

IT: Come si usa?

135017

SPIDERMAN

Troqueladas - Pre-cut

Pré-découpées - Sagomati

6,5 x 4 cm

6 x 6 x 2 x 10



OBLEA

Wafer · Azyme · Obreia · Cialda

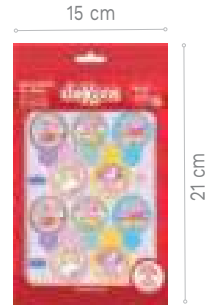

135050

PEPPA PIG

Troqueladas - Pre-cut - Pré-découpées - Sagomati

6,5 x 4 cm · x 6 x 2 x 10



135021

PATRULLA CANINA

Troqueladas - Pre-cut - Pré-découpées - Sagomati

6,5 x 4 cm · x 6 x 2 x 10



135013

FROZEN

Troqueladas - Pre-cut - Pré-découpées - Sagomati

6,5 x 4 cm · x 6 x 2 x 10



Oblea

Wafer · Azyme

Obreia · Cialda



deKora

Special moments

OBLEA

Wafer · Azyme · Obreia · Cialda



NEW

126176

14 cm · 1 u.



FLOWERS
SIZE
XL



NEW

126177

14 cm · 1 u.



NEW

126175

14 cm · 1 u.



NEW

126178

13 cm · 1 u.



NEW

126179

13 cm · 1 u.





FLOWERS
SIZE
XL

NEW

126181

12 cm · 1 u.



NEW

126180

12 cm · 1 u.



NEW

126193

12,5 cm · 1 u.



NEW

126195

12,5 cm · 1 u.



NEW

126192

12,5 cm · 1 u.



NEW

126194

12,5 cm · 1 u.





126140

12,5 cm · 1 u.

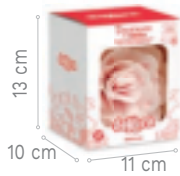

126142

12,5 cm · 1 u.



126141

12,5 cm · 1 u.





126172
12,5 cm · 1 u.



126174
12,5 cm · 1 u.



126173
12,5 cm · 1 u.



Wafer · Azyme · Obreia · Cialda



126162
5,5 cm · 18 u.



126163
5,5 cm · 18 u.



126155
7 cm · 15 u.



126154
7 cm · 15 u.



OBLEA

Wafer · Azyme · Obreia · Cialda



126065
4,5 cm · 36 u.



126158
6,5 - 7 cm · x 6 u.



126150
6,5 - 7 cm · 6 u.





126165

8,5 x 7,5 cm ·  x 10 u.



126164

8,5 x 7,5 cm ·  x 10 u.



126067

8,5 x 7,5 cm ·  x 10 u.



126151

8,5 x 7,5 cm ·  x 10 u.



126156

8,5 x 7,5 cm ·  x 10 u.



126066

8,5 x 7,5 cm ·  x 10 u.



126157

8,5 x 7,5 cm ·  x 10 u.





NEW 126190
4 cm · 18 u.



NEW 126189
4 cm · 18 u.



NEW 126191
4 cm · 18 u.



NEW 126188
4 cm · 18 u.



126166
4,5 cm · 12 u.



126149
4,5 cm · 12 u.



OBLEA

Wafer · Azyme · Obreia · Cialda



NEW

126183

Ø 7 cm · 6 u.



126171

Ø 7 cm · 15 u.



126161

7 cm · 15 u.





NEW 126187
7 cm · 10 u.



NEW 126184
7 cm · 10 u.

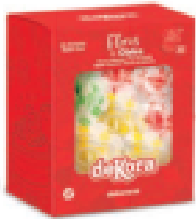

NEW 126186
7 cm · 6 u.





NEW

126182

7 cm ·  15 u.



126091

4,5 cm ·  150 u.



126086

4,5 cm ·  150 u.



126033

4,5 cm ·  100 u.



126027

4,5 cm. ·  x 100 u.





NEW **166033**
4,5 cm · 8 u.



NEW **126185**
3,5 cm · 35 u.



NEW **166034**
4,5 cm · 8 u.



NEW **166032**
4,5 cm · 8 u.



NEW **166031**
4,5 cm · 8 u.

OBLEA

Wafer · Azyme · Obreia · Cialda



126168

2 cm · 400 u.



126167

2 cm · 400 u.



126138

2 cm · 400 u.



126069

2 cm · 400 u.



126068

2 cm · 400 u.



OBLEA

Wafer · Azyme · Obreia · Cialda



126100
4 cm ·  120 u.



126043
5 cm ·  100 u.

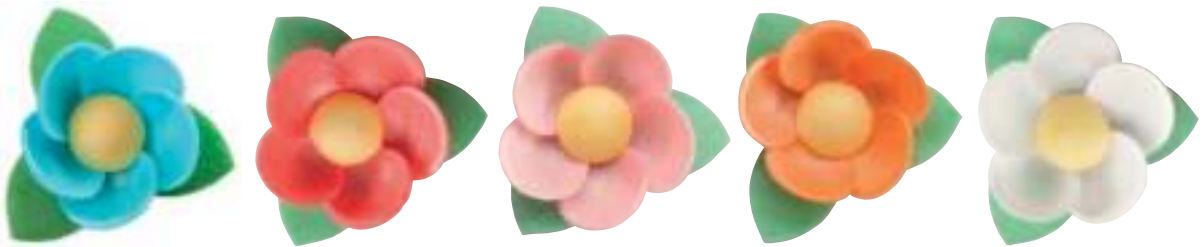

126023
4,5 cm ·  100 u.



Wafer · Azyme · Obreia · Cialda



126128

3 cm · 100 u.



126160

3 cm · 100 u.



126010

4 cm · 72 u.



126008

4 cm · 72 u.



126007

4 cm · 72 u.



126084

4,5 cm · 50 u.



126083

4,5 cm · 50 u.



126080

4,5 cm · 50 u.



126081

4,5 cm · 50 u.



126082

4,5 cm · 50 u.





126092
3 cm · 150 u.



126095
3 cm · 150 u.

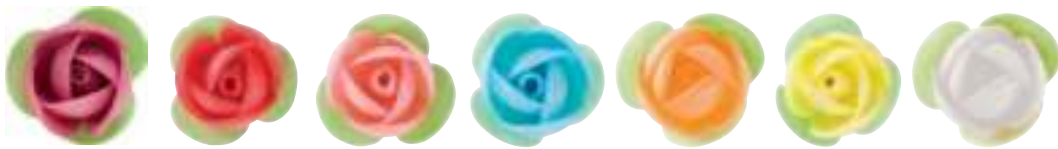

126132
3,5 cm · 140 u.

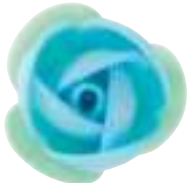

126134
3,5 cm · 140 u.



126135
3,5 cm · 140 u.



126133
3,5 cm · 140 u.



126056
4 cm · 80 u.



126025
4 cm · 100 u.



OBLEA

Wafer · Azyme · Obreia · Cialda



126130

4 cm

75 u.



126137

6,5 x 6,5 cm

30 u.



126136

6,5 cm · 80 u.



126107

8,5 cm

50 u.





126070
 PERLADA - Pearl
 Nacré - Pérola
 4,2 cm · 400 u.



126074
 PERLADA - Pearl
 Nacré - Pérola
 4,2 cm · 400 u.



126071
 PERLADA - Pearl
 Nacré - Pérola
 4,2 cm · 400 u.



115017
 4,5 cm · 1000 u.



115013
 4,5 cm · 1000 u.



115009
 4,5 cm · 500 u.



130010
 4 cm · 200 u.





126170
3-6 cm · 79 u.



126169
3-6 cm · 79 u.



126139
3-6 cm · 87 u.



126148
3-6 cm · 79 u.

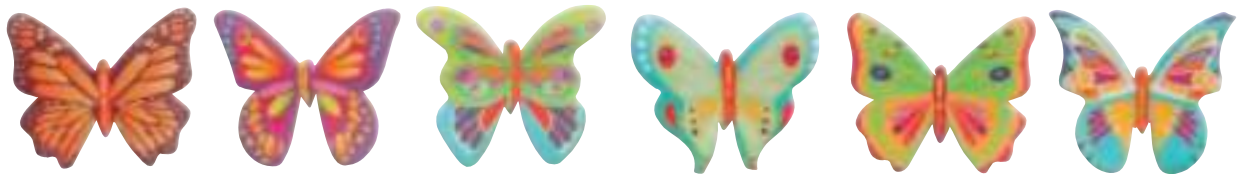

126000
4 cm · 200 u.



OBLEA

Wafer · Azyme · Obreia · Cialda



115020
Ø 1,5 cm
504 u.



115000
2D
5 cm · 200 u.



126076
2D
2 cm · 495 u.



115018
3,5 cm
200 u.



WAFER CAKE DECORATION KITS

Kits decoraciones de Oblea - Kits décorations en Azyme - Kits decorações em Obreia
Kit decorazioni cialda



16,4 cm

7,8 cm



166015

Surtido - Assortment
Assortiment - Sortimento
Assortimento
x 15 x 8 u.

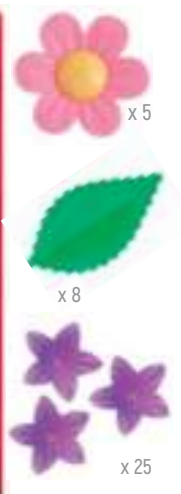

166020

x 8

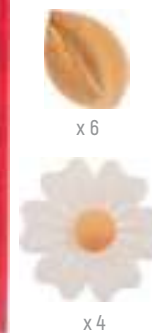

NEW 166035

x 12



166014

Surtido - Assortment
Assortiment - Sortimento
Assortimento
x 24 x 8 u.



166016

Surtido - Assortment
Assortiment - Sortimento
Assortimento
x 6 x 8 u.



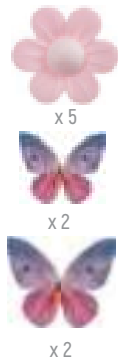

166022

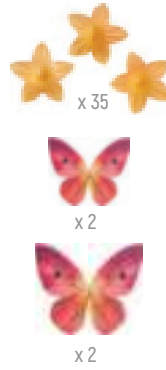
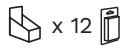

166023

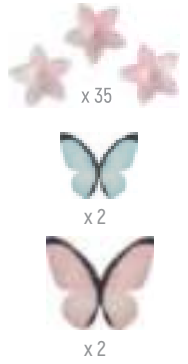
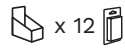

166024

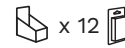

17 cm



166017

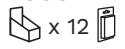

19 cm



NEW 166038

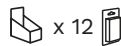

NEW 166039

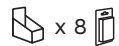

x3 x1
x5 x5
x1 x1
x1 x1

NEW 166037
x 12

Icons: wheat, leaf, bottle, CASEIN FREE, recycling.

x3 x1
x5 x5
x1 x1
x1 x1

NEW 166036
x 12

Icons: wheat, leaf, bottle, CASEIN FREE, recycling.



135111

9,2 x 3,2 cm · x 3 x 40 u. = 120 u.



135112

9,2 x 3,2 cm · x 3 x 40 u. = 120 u.

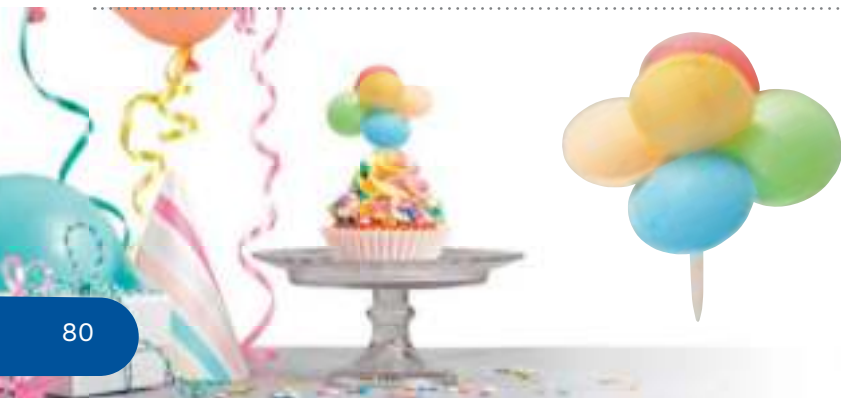

126006

GLOBOS DE OBLEA

Wafer globes - Ballons en azyme -
Globos de obreia - Palloncini di cialda
8 cm · 50 u.



OBLEA INDUSTRIAL

Industrial wafer - Azyme industrielle - Obreia industrial - Cialda industriale



107033

Ø 20 cm
150 u.



OBLEA INDUSTRIAL CIRCULAR: 1 CARA LISA/ 1 CARA RAYADA

Industrial wafer rounded: 1 Face smooth / 1 face lined.
Azyme industrielle ronde: 1 Face lisse / 1 face rayée.
Obreia industrial circular: 1 Cara lisa / 1 cara rayada.
Cialda industriale circolare: 1 Faccia liscia / 1 faccia rigata.



107020

50 x 40 cm
2 kg.



OBLEA INDUSTRIAL RECTANGULAR: 1 CARA LISA/ 1 CARA RAYADA

Industrial wafer rectangular: 1 Face smooth / 1 face lined.
Azyme industrielle rectangulaire: 1 Face lisse / 1 face rayée.
Obreia industrial retangular: 1 Cara lisa / 1 cara rayada.
Cialda industriale rettangolare: 1 Faccia liscia / 1 faccia rigata.

107022

70 x 40 cm
3 kg.



OBLEA PARA IMPRIMIR

Wafer ready to print · Azyme pour imprimer · Obreia para imprimir · Cialda da stampare



107127

DOBLE CARA LISA

Double smooth face
Double face lisse.
Doppia faccia liscia.
29,7 x 42 cm - DIN A3
50 u. · 0,6 mm. aprox



107117

DOBLE CARA LISA

Double smooth face
Double face lisse.
Doppia faccia liscia.
21 x 29,7 cm - DIN A4
50 u.
650 g. aprox. · 0,6 mm. aprox



107031

UNA CARA LISA PARA MÁQUINAS DE ULTIMA GENERACIÓN

One smooth face for new
generations printers.
Une face lisse.
Una faccia liscia per macchine di
ultima generazione
21 x 29,7 cm - DIN A4
50 u.
270 g. aprox. · 0,27 mm. aprox



LETREROS PERSONALIZADOS

Edible label - Label comestible - Obreia personalizada

Targhette personalizzate commestibili



400000

LETRERO OBLEA PERSONALIZADO CALIDAD DD

Wafer edible label DD - Étiquette comestible en azyme - Obreia personalizada DD - Targhetta cialda personalizzata qualità DD
4 cm ·  200 u.

270 g. aprox. · 0,27 mm. aprox

PEDIDO MÍNIMO

Minimum order - Minimum commande
Ordine minimo: 15.000 u.



400001

LETRERO OBLEA OVALADA PERSONALIZADA CALIDAD DD

Wafer edible label DD - Étiquette comestible en azyme - Obreia personalizada DD - Targhetta cialda personalizzata qualità DD
2,5 x 4 cm ·  200 u.

270 g. aprox. · 0,27 mm. aprox

PEDIDO MÍNIMO

Minimum order - Minimum commande
Ordine minimo: 15.000 u.



Azúcar

Sugar · Sucre

Açúcar · Zuccherò



deKora

www.dekora.com

AZÚCAR

Sugar · Sucre · Açúcar · Zucchero



NEW

205216
3D
2 x 3,5 cm
48 u.



205120
3D
4,5 x 3,5 cm · 48 u.



205124
3D
4 x 4,4 cm · 48 u.



205014
3D
2,9 x 3,2 cm · 48 u.



205077
2D
2,8 x 3,1 cm · 48 u.



AZÚCAR

Sugar · Sucre · Açúcar · Zucchero



NEW

205213

2D

A: 2,5 x 3,3 cm

B: 2,5 x 2,5 cm

C: 2,5 x 2 cm

D: 3,5 x 2 cm

E: 3 x 3 cm

F: 3 x 3,5 cm

56 u.



205135

2D

4 x 4,4 cm · 48 u.



205118

3D

2,5 x 2,7 cm · 48 u.



205119

2D

2,8 x 3 cm · 48 u.



AZÚCAR

Sugar · Sucre · Açúcar · Zucchero



205201

2D

4 cm ·  24 u.



A

A

B

C

C

205202

2D

A: 4,5 x 2,5 x 0,9 cm

B: 3,5 x 1,8 x 0,9 cm

C: 3 x 2 x 0,6 cm

 48 u.



205159

3D

1,5 cm ·  100 u.



211100

2D

5 cm ·  60 u.



AZÚCAR

Sugar · Sucre · Açúcar · Zucchero



205204

2D

3 x 2 cm ·  48 u.



(A)



(B)



(C)



(D)

205203

2D SABOR MERENGUE

Meringue flavour

Goût de meringue

Sabor a merengue

Sabor merengue

A: 3,5 x 3 x 0,8 cm

B: Ø 2 x 0,5 cm

C: 3 x 2,5 x 0,8 cm

 50 u.



(A)



(A)



(A)



(B)



(B)

205200

2D

A: 4,5 cm

B: 2,5 x 3 cm

 25 u.



AZÚCAR

Sugar · Sucre · Açúcar · Zucchero



205133

3D

4 x 4,4 cm ·  48 u.



211111

2D

A: 4,5 x 6 cm / B: 4,2 x 7 cm

C: 4,9 x 5,9 cm / D: 5,4 x 2,9 cm

E: 6 x 3,1 cm

 50 u.



230042

2D

14 g · 2 - 3 cm.

 x 15  x 8 u.



AZÚCAR

Sugar · Sucre · Açúcar · Zucchero

NEW

205212

2D

A: 4 x 3,5 cm / B: 3,5 x 4 cm

C: 3 x 4 cm / D: 4 x 2 cm

E: 2,5 x 2 cm / F: 2,5 x 3,5

G: 4 x 2 cm / H: 1 x 4 cm

48 u.



NEW

205218

2D

A: 5 x 3,5 cm

B: 2 x 3,5 cm

C: 4 x 3 cm

48 u.



230035

2D

19 g · 2 - 3 cm.

15 x 8 u.



AZÚCAR

Sugar · Sucre · Açúcar · Zucchero



NEW

205214

2D

A: 4 x 3 cm

B: 2 x 4,5 cm

C: Ø 3 cm

D: 3 x 2 cm

48 u.



NEW

205229

2D

A: 2,4 x 3,8 cm

B: 3,3 x 4 cm

48 u.



NEW

205215

2D

3 - 3,5 cm

48 u.



AZÚCAR

Sugar · Sucre · Açúcar · Zucchero



NEW

205223

2D

A: 1,5 x 5 cm

B: 3,5 x 2 cm

24 u.



NEW

205217

2D

A: 5 x 2 cm

B: 6 x 1 cm

C: 2 x 5 cm

D: 2,5 x 4 cm

24 u.



NEW

205224

2D

A: 4,2 x 3 cm

B: 5,1 x 4,8 cm

C: 4,2 x 2 cm

D: 3,5 x 10,4 cm

48 u.



AZÚCAR

Sugar · Sucre · Açúcar · Zucchero



NEW

205228

2D

Ø 3 cm

100 u.



Ⓐ

NEW

205220

2D

A: 2 x 5 cm

B: Ø 4 cm

32 u.



Ⓑ



Ⓐ

Ⓓ

NEW

205225

2D

A: 4 x 5,5 cm

B: 5 x 2 cm

C: 4 x 2,5 cm

D: 3,5 x 4 cm

30 u.



Ⓑ



Ⓒ



AZÚCAR

Sugar · Sucre · Açúcar · Zucchero



NEW

205219

2D

A: 2 x 4,5 cm

B: 3 x 5,5 cm

C: 3,5 x 3,5 cm

D: 2 x 4,5 cm

30 u.



NEW

205221

2D

A: 3,5 x 4 cm

B: 3,5 x 3,5 cm

C: 3,5 x 3,5 cm

D: 5 x 2 cm

E: 3 x 4,5 cm

30 u.



(A)



(B)

NEW

205222

2D

A: 1 x 3,5 cm

B: 4,5 x 3,5 cm

18 u.



AZÚCAR

Sugar · Sucre · Açúcar · Zucchero



210092

AZÚCAR BLANDO

Soft sugar - Sucre doux

Açúcar mole - Zucchero morbido

3,5 x 1,8 cm ·  36 u.



210058

Ø 4 cm ·  36 u.



210117

Ø 7 cm ·  6 u.



210021

Ø 2 cm ·  100 u.



210022

Ø 3 cm ·  76 u.



210056

Ø 4 cm ·  36 u.



AZÚCAR

Sugar · Sucre · Açúcar · Zucchero



205158

3 x 3 cm ·  48 u.



210112

PERLADA

Pearl - Nacré - Pérola

Perlata

Ø 4 cm ·  16 u.



210104

Ø 5 cm ·  10 u.



210019

Ø 2 cm ·  128 u.



AZÚCAR

Sugar · Sucre · Açúcar · Zucchero



210020

Ø 3,5 cm

36 u.



205108

6 X 2,5 cm · 48 u.



210131

7 cm. · 6 u.



AZÚCAR

Sugar · Sucre · Açúcar · Zucchero



210067

Ø 4 cm

40 u.



210121

Ø 1,5 cm · 500 u.



210028

Ø 3,5 cm

64 u.



210122

Ø 2,5 cm

150 u.



AZÚCAR

Sugar · Sucre · Açúcar · Zucchero



211005

Ø 2,5 cm

📦 288 u.



211007

Ø 1,5 cm

📦 490 u.



211024

Ø 2 cm

📦 315 u.



210114

Ø 2 cm

📦 250 u.



210046

Ø 4 cm · 📦 75 u.



210013

Ø 4 cm · 📦 40 u.



AZÚCAR

Sugar · Sucre · Açúcar · Zucchero



210129

1,5 - 2,5 cm. ·  210 u.



210133

Ø 3,2 cm

 45 u.



210130

Ø 4,5 cm

 48 u.



210132

Ø 6,5 cm

 12 u.



AZÚCAR

Sugar · Sucre · Açúcar · Zucchero



211004
3,5 cm
100 u.



211013
3,5 cm
96 u.



211090
Ø 2,5 cm · 120 u.



205109
5,7 x 4,2 cm · 24 u.



205157
67 u. (40A + 27B)
A: 4,5 x 3,5 cm.
B: 6,5 x 5,5 cm.



205156
3,7 cm.
200 u.



AZÚCAR

Sugar · Sucre · Açúcar · Zucchero



NEW 230074
8 + 2
 x 12



NEW 230073
8 + 2
 x 12



230059
7 + 7
 x 12



230060
7 + 7
 x 12



AZÚCAR

Sugar · Sucre · Açúcar · Zucchero



230063

8 + 5

x 12



230064

8 + 5

x 12



230062

8 + 5

x 12



230061

8 + 5

x 12



AZÚCAR

Sugar · Sucre · Açúcar · Zucchero

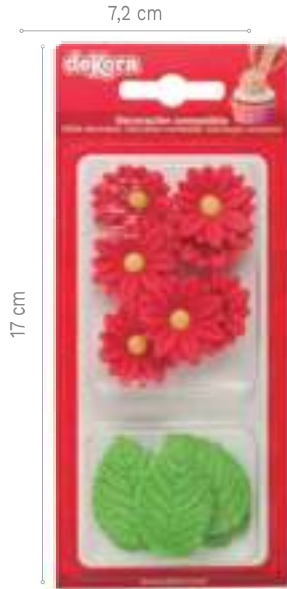

17 cm

7,2 cm



230058

7 + 5

x 12



230057

7 + 5

x 12



230065

5 + 4 oblea/wafer

x 12



AZÚCAR

Sugar · Sucre · Açúcar · Zucchero



210080

6,5 x 6,5 / 4,5 x 4,5 cm.

14 u. (5A + 5B + 2C + 2D)

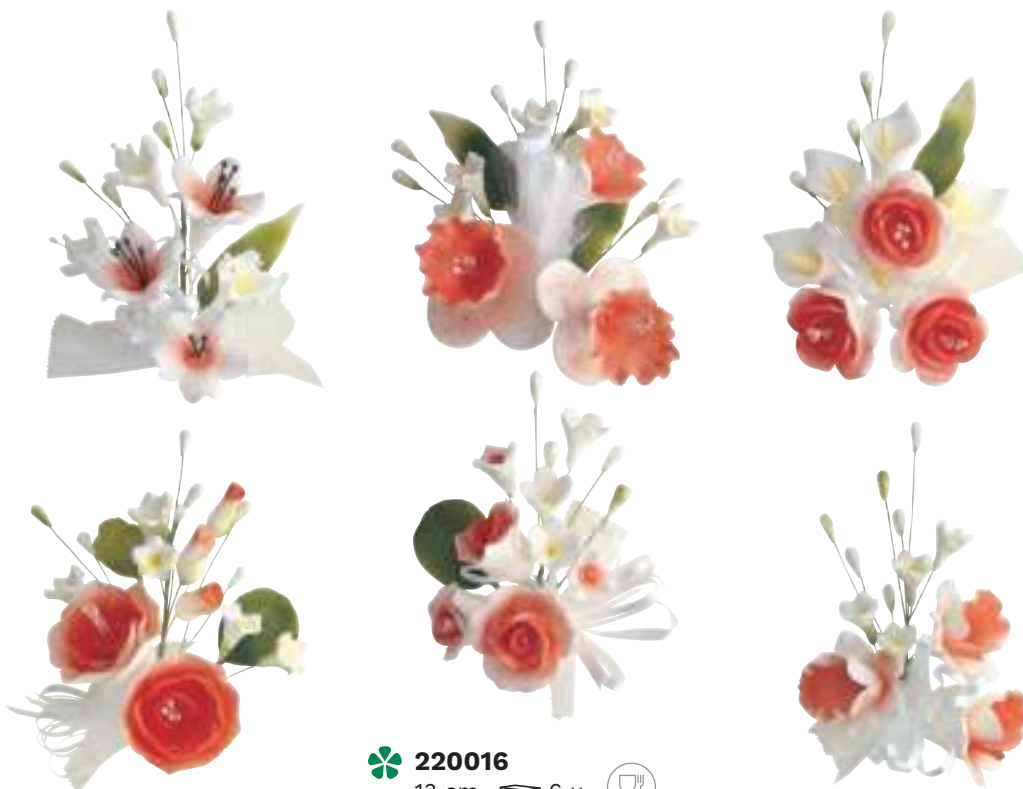

220016

13 cm · 6 u.



DEKORA RECOMIENDA NO INGERIR ESTOS PRODUCTOS PORQUE CONTIENEN PARTES METÁLICAS

EN: Dekora recommends not to swallow these products since they contain metallic parts

FR: Dekora recommande de ne pas ingérer ces produits car ils contiennent des parties métalliques

PT: Dekora recomenda no ingerir estes produtos porque contém partes metálicas.

IT: Dekora sconsiglia di ingerire questi prodotti poiché contengono particelle di metallo.

AZÚCAR

Sugar · Sucre · Açúcar · Zucchero



H: 14 cm



H: 14 cm



H: 10 cm



H: 10 cm



220020 ENVASADO INDIVIDUAL

Individual packaging

Emballé individuel

Embalado individual

Confezione individuale

6 u.



H: 10 cm



DEKORA RECOMIENDA NO INGERIR ESTOS PRODUCTOS PORQUE CONTIENEN PARTES METÁLICAS

EN: Dekora recommends not to swallow these products since they contain metallic parts

FR: Dekora recommande de ne pas ingérer ces produits car ils contiennent des parties métalliques

PT: Dekora recomenda no ingerir estes produtos porque contém partes metálicas.

IT: Dekora sconsiglia di ingerire questi prodotti poiché contengono particelle di metallo.



AZÚCAR

Sugar · Sucre · Açúcar · Zucchero





 **211106**
7,6 cm ·  20 u.



 **210016**
9 x 9 / 6 x 6 cm.
 14 u.



 **211105**
8 cm ·  20 u.



 **210018**
8 x 8 cm ·  20 u.



 DEKORA RECOMIENDA NO INGERIR ESTOS PRODUCTOS PORQUE CONTIENEN PARTES METÁLICAS

 Dekora recommends not to swallow these products since they contain metallic parts

 Dekora recommande de ne pas ingérer ces produits car ils contiennent des parties métalliques

 Dekora recomienda no ingerir estos productos porque contienen partes metálicas.

 Dekora sconsiglia di ingerire questi prodotti poiché contengono particelle di metallo.

AZÚCAR





Sugar · Sucre · Açúcar · Zucchero



 **220011**
10,5 cm ·  6 u. 



 **220012**
10,5 cm ·  6 u. 

-  DEKORA RECOMIENDA NO INGERIR ESTOS PRODUCTOS PORQUE CONTIENEN PARTES METÁLICAS
-  Dekora recommends not to swallow these products since they contain metallic parts
 -  Dekora recommande de ne pas ingérer ces produits car ils contiennent des parties métalliques
 -  Dekora recomienda no ingerir estos productos porque contêm partes metálicas.
 -  Dekora sconsiglia di ingerire questi prodotti poiché contengono particelle di metallo.

AZÚCAR

Sugar · Sucre · Açúcar · Zucchero









 **220004**
15 cm ·  6 u.

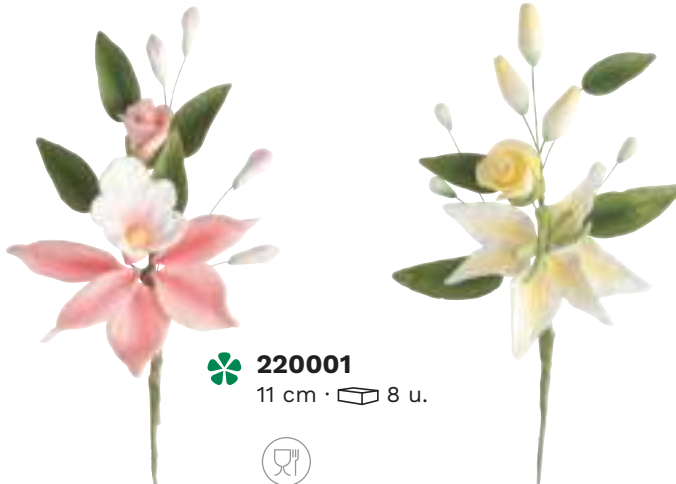

AZÚCAR

Sugar · Sucre · Açúcar · Zucchero



-  DEKORA RECOMIENDA NO INGERIR ESTOS PRODUCTOS PORQUE CONTIENEN PARTES METÁLICAS
-  Dekora recommends not to swallow these products since they contain metallic parts
-  Dekora recommande de ne pas ingérer ces produits car ils contiennent des parties métalliques
-  Dekora recomienda no ingerir estos productos porque contêm partes metálicas.
-  Dekora sconsiglia di ingerire questi prodotti poiché contengono particelle di metallo.

AZÚCAR

Sugar · Sucre · Açúcar · Zucchero



 DEKORA RECOMIENDA NO INGERIR ESTOS PRODUCTOS PORQUE CONTIENEN PARTES METÁLICAS

 Dekora recommends not to swallow these products since they contain metallic parts

 Dekora recommande de ne pas ingérer ces produits car ils contiennent des parties métalliques

 Dekora recomienda no ingerir estos productos porque contienen partes metálicas.

 Dekora sconsiglia di ingerire questi prodotti poiché contengono particelle di metallo.

AZÚCAR

Sugar · Sucre · Açúcar · Zucchero





 **210026**
15 cm ·  5 u.



 **DEKORA RECOMIENDA NO INGERIR ESTOS PRODUCTOS PORQUE CONTIENEN PARTES METÁLICAS**

 Dekora recommends not to swallow these products since they contain metallic parts

 Dekora recommande de ne pas ingérer ces produits car ils contiennent des parties métalliques

 Dekora recomenda no ingerir estes produtos porque contém partes metálicas.

 Dekora sconsiglia di ingerire questi prodotti poiché contengono particelle di metallo.



AZÚCAR

Sugar · Sucre · Açúcar · Zucchero



 **211109**
26 cm ·  12 u. (4 x 3)



 **211043**
26 cm ·  12 u. (4 x 3) 



 **211108**
26 cm ·  12 u. (4 x 3) 

 DEKORA RECOMIENDA NO INGERIR ESTOS PRODUCTOS PORQUE CONTIENEN PARTES METÁLICAS

 Dekora recommends not to swallow these products since they contain metallic parts

 Dekora recommande de ne pas ingérer ces produits car ils contiennent des parties métalliques

 Dekora recomienda no ingerir estos productos porque contienen partes metálicas.

 Dekora sconsiglia di ingerire questi prodotti poiché contengono particelle di metallo.

Topping

Topping decoration · Décoration topping
Decoração topping
Decorazione topping



deKora

Special moments

TOPPING

Topping decoration · Décoration topping · Decoração topping · Decorazione topping

PERLAS

Pearls · Perles · Pérola · Perle

AZÚCAR + CHOCOLATE + CRUJIENTE

EN: Sugar + Chocolate + Crispy. **FR:** Sucre + Chocolat + Croquant. **PT:** Açúcar + Chocolate + Crocante. **IT:** Zucchero + Cioccolato + Crocante.

IDEALES PARA DECORAR TARTAS, BIZCOCHOS, POSTRES, ETC. FIJACIÓN PERFECTA EN FRIGORÍFICO, Y ABATIDOR.

EN: Ideal for decorating cakes, biscuits, desserts, etc. Perfect hold in the fridge and in the blast chiller. FR: Parfaits pour décorer des tartes, gâteaux, etc. Tenue parfaite au réfrigérateur et au congélateur. PT: Ideais para decorar bolos, biscoitos, sobremesas, etc. Consistência perfeita no frigorífico ou congelador. IT: Perfetti per la decorazione di torte, ciambelle, dolci, ecc. Fissaggio ottimale in frigo o abbattitore.



433071

Ø 0,5 - 0,6 cm ·  350 g



433073

Ø 0,5 - 0,6 cm ·  350 g



433083

Ø 1,7 - 2 cm ·  350 g



433079

Ø 0,6 cm
 350 g



YouTube



433080

Ø 0,6 cm
 350 g



TOPPING

Topping decoration · Décoration topping · Decoração topping · Decorazione topping

AZÚCAR

EN: Sugar. FR: Sucre. PT: Açúcar. IT: Zucchero.



433082

Ø 0,2 cm · 500 g



433011

Ø 0,4 cm · 500 g



YouTube

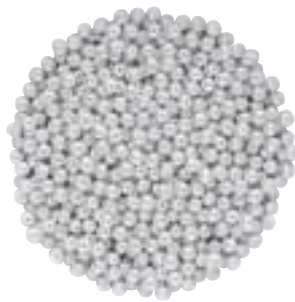

433002

Ø 0,4 cm · 500 g



433004

Ø 0,6 cm · 500 g

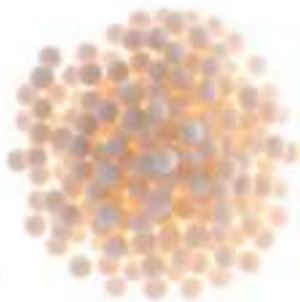

433084

Ø 0,5 cm · 450 g



433009

Ø 0,6 cm · 4 Kg



TOPPING

Topping decoration · Décoration topping · Decoração topping · Decorazione topping
AZÚCAR · SUGAR · SUCRE · AÇÚCAR · ZUCCHERO

FIDEOS DE AZÚCAR

Sugar strands · Vermicelles en sucret · Fidéus de açúcar · Fedelini di zucchero



440025

1,2 kg



440026

1,2 kg



440004

1,2 kg



440031

450 g

NEW



440007

20 kg



440029

1,2 kg



440023

1,2 kg



440024

1,2 kg



<20ppm gluten REG. 1169/2011

443016

25 kg



443006

1,5 kg



NEW

443008

500 g



TOPPING

Topping decoration · Décoration topping · Decoração topping · Decorazione topping

FIDEOS DE OBLEA

Colour wafer strands · Vermicelles en azyme · Fidéus de obreia · Fedelini di cialda



440014

x 210 g



440016

x 210 g

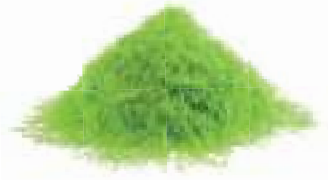

440017

x 210 g



CONFETTI

Azúcar- Sugar - Sucre- Zucchero



445084

1 kg



Presentación / Presentation



445082

1 kg



445018

1 kg



445021

1 kg



445020

1 kg



445019

1 kg



TOPPING

Topping decoration · Décoration topping · Decoração topping · Decorazione topping

AZÚCAR · SUGAR · SUCRE · AÇÚCAR · ZUCCHERO

CONFETTI

Confete



434015
CORAZONES
Hearts - Coeurs
Corações - Cuori
100 g · x 8



434016
BABY BOY
100 g · x 8



434017
BABY GIRL
100 g · x 8



434020
CONFETTI
100 g · x 8



434021
HUEVOS
Eggs - Œufs
Ovos - Uova
100 g · x 8



434009
CORAZONES
Hearts - Coeurs
Corações - Cuori
100 g · x 8



434007
ESTRELLAS
Stars - Étoiles
Estrelas - Stelle
100 g · x 8



TOPPING

Topping decoration · Décoration topping · Decoração topping · Decorazione topping

AZÚCAR · SUGAR · SUCRE · AÇÚCAR · ZUCCHERO



OJOS DE CARAMELO

Candy eyeballs · Bonbons yeux · Olhos de caramelo · Occi di caramella



230051

56 g x 

 x 10 



CHOCOLATE CRISPY

Chocolate + Crispy · Chocolat + Croquant
Chocolate + Crocante · Cioccolato + Crocante



YouTube



YouTube

433067

70 g ·  x 8 

Surtidas - Assorted

Assorties - Sortidas

Assortimento



TOPPING

Topping decoration · Décoration topping · Decoração topping · Decorazione topping

AZÚCAR · SUGAR · SUCRE · AÇÚCAR · ZUCCHERO

MERENGUITOS

Meringue

211101

 350 g



211103

 350 g



9,3 cm

6,2 cm



210061

 90 g



210062

 90 g



210063

 90 g



210059

 80 g



210060

 80 g



210103

 90 g

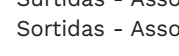

Surtidas - Assorted - Assorties
Sortidas - Assortimento





TOPPING

Topping decoration · Décoration topping · Decoração topping · Decorazione topping
AZÚCAR · SUGAR · SUCRE · AÇÚCAR · ZUCCHERO

AZÚCARES BRILLANTES

Bright sugars · Sucres colorés · Açúcares brilhantes · Brillantini di zucchero

IDEALES PARA DECORAR TARTAS, BIZCOCHOS, POSTRES, ETC. FIJACIÓN PERFECTA EN FRIGORÍFICO, ABATIDOR Y HORNO.

EN: Ideal for decorating cakes, biscuits, desserts, etc. Perfect hold in the fridge, in the blast chiller and oven. FR: Parfaits pour décorer des tartes, gâteaux, etc. Tenue parfaite au réfrigérateur, au congélateur et au four. PT: Ideais para decorar bolos, biscoitos, sobremesas, etc. Consistência perfeita no frigorífico, congelador ou forno. IT: Perfetti per la decorazione di torte, ciambelle, dolci, ecc. Fissaggio ottimale in frigo, abbattitore o forno.

NEW

445093

PLATA - Silver

Argent - Prata - Argento

900 g



NEW

445092

RUBÍ

900 g



NEW

445091

ORO - Gold - Or - Ouro

900 g



Chocolate

Chocolate · Chocolat · Cioccolato



deKora

Special moments

CHOCOLATE

Chocolate · Chocolat · Cioccolato



NEW

428158

2D

Blanco - White - Blanc - Branco - Bianco

2,7 x 3,1 cm ·  40 u.



NEW

428172

2D

Blanco - White - Blanc - Branco - Bianco

A: 4,2 x 3,8 cm / B: 3,4 x 3,8 cm / C: 3,7 x 4 cm / D: 2,8 x 4,3 cm / E: 4,2 x 3,9 cm / F: 5,1 x 4,5 cm

 36 u.



NEW

428174

2D

Blanco - White - Blanc - Branco - Bianco

3,9 cm ·  48 u.



CHOCOLATE

Chocolate · Chocolat · Cioccolato



NEW

428178

2D

Negro - Dark - Noir - Preto - Nero

2 - 2,5 cm · 224 u.



NEW

428179

2D

Negro - Dark - Noir - Preto - Nero

1,5 x 4,5 cm · 180 u.



NEW

428157

2D

Con leche - With milk - Au lait Com leite - Al latte

4,5 x 3 cm · 90 u.



NEW

428176

2D

Blanco - White - Blanc - Branco - Bianco

Ø 2,7 cm · 312 u.



NEW

428154

2D

Blanco - White - Blanc - Branco - Bianco

A: 2,7 x 4,7 cm / B: 3,2 x 4,9

C: 3 x 4,5 cm · 141 u.



(A)



(B)



(C)



(B)



(A)



(C)



428103

3D

Blanco - White - Blanc

Branco - Bianco

A: 4,2 x 3,4 cm

B: 4,4 x 4 cm

C: 4,2 x 2,7 cm

180 u.



CHOCOLATE

Chocolate · Chocolat · Cioccolato



NEW

428153

2D

Blanco - White - Blanc - Branco - Bianco

A: 2,5 x 5 cm / B: 4 x 4,5 cm / C: 3 x 4,5 cm / D: 4 x 3,1 cm / E: 4,5 x 4,3 cm · 48 u.



428090

2D

Blanco - White - Blanc - Branco - Bianco

Ø 3 cm · 135 u.

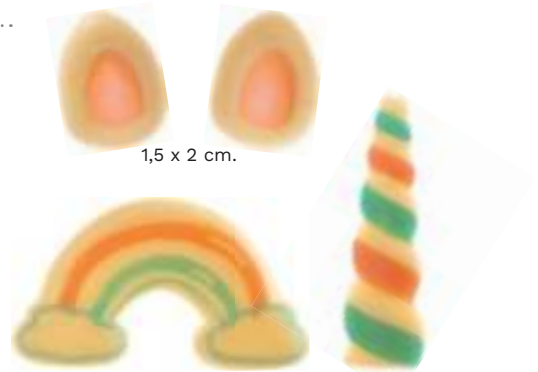

1,5 x 2 cm.

4,3 x 2 cm.

1,2 x 4 cm.

NEW

428152

2D

Blanco - White - Blanc - Branco - Bianco

60 u.



NEW

428156

2D

Blanco - White - Blanc - Branco - Bianco

3,5 x 4 cm · 152 u.



NEW

428155

2D

Blanco - White - Blanc - Branco - Bianco

3,1 x 3,5 cm · 108 u.



CHOCOLATE

Chocolate · Chocolat · Cioccolato



427895

2D

Blanco - White - Blanc

Branco - Bianco

4,5 x 2,7 cm ·  140 u.



NEW

428138

2D

Negro - Dark - Noir - Preto - Nero

3 - 4 cm ·  50 u.





CHOCOLATE

Chocolate · Chocolat · Cioccolato



NEW

428148

2D

Con leche - With milk
Au lait Com leite
Al latte

3,5 x 7,3 cm ·  3 u.



NEW

428150

2D

Con leche - With milk
Au lait Com leite
Al latte

2 x 7,3 cm ·  4 u.



NEW

428151

2D

Con leche - With milk
Au lait Com leite
Al latte

12 x 7,7 cm ·  3 u.



12 x 7,7 cm.



3,5 x 7,3 cm.



5,7 x 11,5 cm.

NEW

428147

2D

Con leche - With milk
Au lait Com leite
Al latte

12 x 7,7 cm ·  4 u.



NEW

428149

2D

Con leche - With milk
Au lait Com leite
Al latte

12 x 7 cm ·  1 u.



CHOCOLATE

Chocolate · Chocolat · Cioccolato



427694
3D

Blanco - White - Blanc - Branco - Bianco
3,8 X 2,8 cm ·  36 u.



428094
3D

Con leche
With milk - Au lait Com leite - Al latte
5,5 x 4 cm ·  48 u.



427784
2D

Blanco - White - Blanc
Branco - Bianco
Ø 5,3 cm ·  36 u.



428111

Blanco - White - Blanc - Branco - Bianco
5,1 x 1,9 cm ·  40 u.



428095
2D

Blanco - White - Blanc - Branco - Bianco
4 x 5 cm ·  36 u.



427692
3D

Blanco - White - Blanc
Branco - Bianco
Ø 3,5 cm ·  36 u.



CHOCOLATE

Chocolate · Chocolat · Cioccolato

428112

Blanco - White - Blanc Branco - Bianco

Ø 3,2 cm

📦 80 u.



NEW

428167

2D

Blanco - White - Blanc - Branco - Bianco

Ø 2 cm · 📦 140 u.



427857

2D

Blanco - White - Blanc - Branco - Bianco

3 x 3,5 cm · 📦 252 u. · 348 g



YouTube

427273

3D

Negro - Dark - Noir - Preto - Nero

Ø 3,5 x H: 1,5 cm

📦 76 u.



427274

3D

Blanco - White - Blanc

Branco - Bianco

Ø 3,5 x H: 1,5 cm · 📦 76 u.



427829

2D

Blanco - White

Blanc - Branco - Bianco

Ø 3,4 cm · 📦 108 u.



427665

3D

Negro - Dark - Noir

Preto - Nero

Ø 4,5 x 3 cm · 📦 15 u.



427666

3D

Blanco - White - Blanc

Branco - Bianco

Ø 4,5 x 3 cm · 📦 15 u.



427907

3D

Blanco - White - Blanc

Branco - Bianco

Ø 4,5 x 3 cm · 📦 15 u.



YouTube

CHOCOLATE

Chocolate · Chocolat · Cioccolato



427658

2D

Surtido - Assortment

Assortiment - Sortiment - Assortite

6 x 3,3 cm · 160 u.



427925

2D

Blanco - White - Blanc - Branco

3,3 x 1,9 cm · 144 u.



427752

2D

Negro - Dark - Noir - Preto - Nero

3 x 4 cm · 90 u.



427667

3D

Negro - Dark - Noir - Preto - Nero

3,5 x 3 x 1,5 cm · 120 u.



NEW

428177

3D

Negro - Dark - Noir - Preto - Nero

H: 5,5 cm · 28 u.



428108

3D

Blanco - White - Blanc - Branco

H: 5,5 cm · 28 u.



CHOCOLATE

Chocolate · Chocolat · Cioccolato



427765

3D

Negro/Blanco - Dark/White - Noir/Blanc

Preto/Branco - Nero/Bianco

Ø 6,5 x H: 3 cm

84 u. · Vol: 60 ml.



427083

3D

Negro - Dark - Noir - Preto - Nero

Ø 4,4 x 2,8 x H: 2 cm

168 u. · Vol: 16 ml.



NEW

428166

3D

Negro - Dark - Noir - Preto - Nero

Ø 3,5 x H: 2,3 cm

294 u. · Vol: 13 ml.



427756

3D

Negro - Dark - Noir - Preto - Nero

Ø 8 x H: 7,5 cm

22 u. · Vol: 100 ml.



427915

3D

Negro - Dark - Noir - Preto - Nero

2,5 x 2,8 cm

150 u.



CHOCOLATE

Chocolate · Chocolat · Cioccolato



428119

3D

Negro - Dark - Noir - Preto - Nero

Ø 3 cm · 56 u.



428171

3D

Blanco - White - Blanc - Branco - Bianco

Ø 3 cm · 56 u.

NEW



427766

3D

Blanco - White - Blanc

Branco - Bianco

Ø 2,7 cm · 40 u.



428113

3D

Blanco - White - Blanc -

Branco - Bianco

Ø 3 cm · 56 u.



427750

3D

Negro - Dark

Noir - Preto - Nero

Ø 3 cm · 40 u.



YouTube



428120

3D

Blanco - White - Blanc

Branco - Bianco

Ø 3 cm

56 u.



CHOCOLATE

Chocolate · Chocolat · Cioccolato



428170

2D

Negro/Blanco - Dark/White
Noir/Blanc - Preto/Branco
Nero/Bianco

4,7 x 3 cm · 153 u.



427323

2D

Negro/Blanco - Dark/White
Noir/Blanc - Preto/Branco
Nero/Bianco

3,5 x 4,5 cm · 420 u.



427610

2D

Negro/Blanco - Dark/White
Noir/Blanc - Preto/Branco
Nero/Bianco

3 x 3 cm · 420 u.



428109

2D

Negro/Blanco - Dark/White
Noir/Blanc - Preto/Branco
Nero/Bianco

5,2 x 3,4 cm · 290 u.



427110

2D

Con leche/Blanco - With milk/White
Au lait/Blanc - Com leite/Branco
Al latte/Bianco

9,6 x 4,5 x 10,5 cm · 131 u.

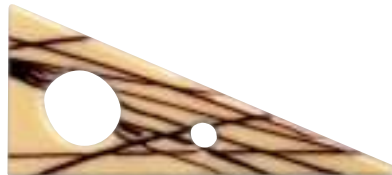

427109

2D

Negro/Blanco - Dark/White
Noir/Blanc - Preto/Branco
Nero/Bianco

9,6 x 4,5 x 10,5 cm · 131 u.



427145

2D

Negro/Blanco - Dark/White
Noir/Blanc - Preto/Branco
Nero/Bianco

3,2 x H: 4,7 cm · 295 u.



427154

2D

Blanco - White - Blanc - Branco - Bianco

4,7 x H: 3,7 cm · 280 u.



427873

2D

Negro/Blanco - Dark/White - Noir/Blanc
Preto/Branco - Nero/ Bianco

6 x 3,8 cm · 220 u. 910 g



CHOCOLATE

Chocolate · Chocolat · Cioccolato



428107

2D

Blanco - White - Blanc - Branco - Bianco
4 x 4 cm · 390 u.

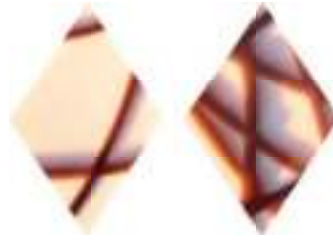

428106

2D

Blanco - White - Blanc - Branco - Bianco
3,5 x 6 cm · 390 u.



427324

2D

Negro/Blanco - Dark/White - Noir/
Blanc - Preto/Branco - Nero/Bianco
3,5 x 4 cm · 415 u.



427325

2D

Negro/Blanco - Dark/White - Noir/
Blanc - Preto/Branco - Nero/Bianco
3 x 3 cm · 485 u.



427926

2D

Blanco - White - Blanc
Branco - Bianco
4,6 x 4,6 cm · 148 u.



427322

2D

Negro/Blanco - Dark/White
Noir/Blanc - Preto/Branco
Nero/Bianco
3,5 x 4 cm · 415 u.



428169

2D

Blanco - White - Blanc
Branco - Bianco
2,9 x 2,9 cm
 135 u.



427753

2D

Negro - Dark - Noir
Preto - Nero
2,9 x 2,9 cm
 135 u.



CHOCOLATE

Chocolate · Chocolat · Cioccolato



427929

2D

Negro - Dark - Noir
Preto - Nero

5 x 5 cm · 112 u.



427462

3D

Negro/Blanco - Dark/White
Noir/Blanc - Preto/Branco
Nero/Bianco

Ø 1,4 - 1,5 x H: 1,9 - 2,3 cm

500 g.



427321

3D

Negro - Dark - Noir
Preto - Nero

1,2 x 1,8 cm · 1,1 kg



427848

2D

Negro - Dark - Noir - Preto - Nero

5,9 x 3,5 x 0,2 cm

400 u. 1 kg



427959

3D

Assortment - Assortiment - Sortiment - Assortite

4,8 x 1,6 cm

108 u.



427100

2D

Negro - Dark
Noir - Preto - Nero

4,5 x 2,5 cm

310 u.



CHOCOLATE

Chocolate · Chocolat · Cioccolato



427835

3D

Negro/Blanco - Dark/White

Noir/Blanc - Preto/Branco - Nero/Bianco

Ø 0,5-1 x 7,5 cm ·  250 g.



427656

3D

Surtido / Assortment

Assortiment / Sortimento / Assortite

 90 u.



427468

3D

Negro/Blanco - Dark/White

Noir/Blanc - Preto/Branco

Nero/Bianco

3,3 cm ·  1,5 kg



427469

3D

Negro/Blanco - Dark/White

Noir/Blanc - Preto/Branco

Nero/Bianco

4 cm ·  2 kg



427811

3D

Negro/Blanco - Dark/White

Noir/Blanc - Preto/Branco

Nero/Bianco

Ø 0,7 x H: 9,4 cm ·  117 u.



427875

3D

Negro/Blanco - Dark/White

Noir/Blanc - Preto/Branco

Nero/Bianco

5,5 cm

 1 kg.



427809

3D

Negro/Blanco - Dark/White

Noir/Blanc - Preto/Branco

Nero/Bianco

Ø 1 x 6/6,5 cm

 144 u.



CHOCOLATE

Chocolate · Chocolat · Cioccolato



427111

2D

Negro - Dark- Noir - Preto - Nero

3,5 x 4,5 cm

275 u. · 700 g



427854

2D

Negro - Dark - Noir - Preto - Nero

6 x 2,2 cm

320 u. · 680 g



427911

2D

Negro - Dark - Noir

Preto - Nero

7,5 x 2,3 x 1,1 cm

48 u.



427830

3D

Negro - Dark - Noir

Preto - Nero

4 x 3 cm · 105 u.



427921

3D

Negro/Blanco - Dark/White

Noir/Blanc - Preto/Branco

Nero/Bianco

5 x 3 cm

333 u.



427831

3D

Blanco - White - Blanc

Branco - Bianco

4 x 3 cm · 105 u.



427467

3D

Negro/Blanco - Dark/White - Noir/Blanc

Preto/Branco - Nero/Bianco

7 x H: 5 cm

2,5 kg ± 250 u.



427214

3D

Negro/Blanco - Dark/White - Noir/Blanc

Preto/Branco - Nero/Bianco

3,3 x H: 2,6 cm

1 kg



CHOCOLATE

Chocolate · Chocolat · Cioccolato



428093
3D
Blanco - White - Blanc
Branco - Bianco
Ø 0,5 x H: 15 cm
📦 120 u.



NEW
428159
3D
Blanco/Leche
White/Milk
Blanc/Lait
Branco/Leite
Bianco/Latte
Ø 0,6 x H: 14 cm
📦 750 g.



NEW
428165
3D
Negro - Dark- Noir
Preto - Nero
Ø 0,6 x H: 20 cm
📦 110 u.



427470
3D
Negro/Blanco - Dark/White
Noir/Blanc - Preto/Branco -
Nero/Bianco
Ø 0,45 x H: 15 cm
📦 700 g ± 154 u.



427733
3D
Ø 1,6 x H: 20 cm
📦 110 u. · 715 g



427734
3D
Ø 1,6 x H: 20 cm
📦 110 u. · 715 g



427737
3D
Ø 1,6 x H: 20 cm
📦 110 u. · 715 g



427670
3D
Blanco - White - Blanc
Branco - Bianco
Ø 0,6 x H: 9,7 cm
📦 210 u.



427657
3D
Surtido - Assortment
Assortiment - Sortimento
Assortite
📦 108 u.



CHOCOLATE

Chocolate · Chocolat · Cioccolato



428091

3D

Blanco - White - Blanc - Branco - Bianco

8,4 x 3 cm ·  80 u.



428092

3D

Negro - Dark - Noir - Preto - Nero

8,4 x 3 cm ·  80 u.



427812

3D

Negro - Dark - Noir - Preto - Nero

3,5 x 8 cm ·  80 u.



427703

3D

Negro - Dark - Noir - Preto - Nero

7,8 x H: 3 cm ·  36 u.



427906

3D

Negro - Dark - Noir - Preto - Nero

8,4 x 3 cm ·  80 u.



427909

3D

Blanco - White - Blanc - Branco - Bianco

3 x H: 17 cm ·  48 u.



CHOCOLATE

Chocolate · Chocolat · Cioccolato



427838

Negro - Dark - Noir - Preto - Nero
0,9 x 0,5 cm · 1 kg

427839

Negro - Dark - Noir - Preto - Nero
0,9 x 0,5 cm · 4 kg



427842

Blanco - White - Blanc - Branco - Bianco
0,9 x 0,5 cm · 1 kg

427843

Blanco - White - Blanc - Branco - Bianco
0,9 x 0,5 cm · 4 kg



427840

Blanco - White - Blanc - Branco - Bianco
0,9 x 0,5 cm · 1 kg

427841

Blanco - White - Blanc - Branco - Bianco
0,9 x 0,5 cm · 1 kg



427844

Con leche - With milk
Au lait - Com leite - Al latte
0,9 x 0,5 cm · 1 kg



427846

Negro - Dark - Noir - Preto - Nero
0,9 x 0,5 cm · 4 kg

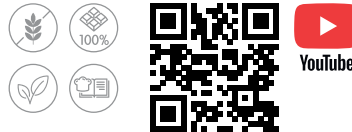

427847

Blanco - White - Blanc - Branco - Bianco
0,9 x 0,5 cm · 4 kg



427089

Negro - Dark - Noir - Preto - Nero
 2,5 kg



427922

Con leche - With milk
Au lait - Com leite - Al latte
2 x 0,5 cm · 1 kg

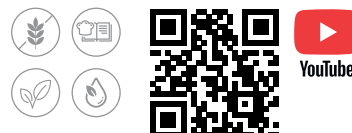

427065

Blanco - White - Blanc - Branco - Bianco
 2,5 kg



CHOCOLATE

Chocolate · Chocolat · Cioccolato



427970

Rosa - Pink
Rose - Rosa

 500 g



427971

Oro blanco - White gold
Or blanc - Ouro branco
Oro bianco

 500 g



427669

2D
Blanco - White - Blanc
Branco - Bianco
+/- 1 cm ·  600 g



427668

Blanco - White - Blanc
Branco - Bianco
+/- 1 cm ·  600 g



433054

Ø 0,5 cm ·  600 g



433056

Ø 1 cm ·  1 kg



LÁMINAS DE SERIGRAFÍA



Silk-screen printing sheets - Lames de sérigraphie - Lâminas de serigrafia - Lamine da serigrafia



545203

28 x 39 cm ·  x 24 LÁMINAS SURTIDAS - Assortment of sheets - Lames assorties - Lâminas sortidas - Lamine assortite

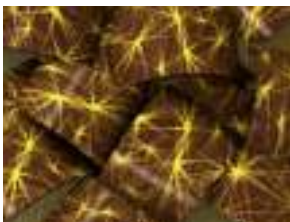

545002

28 x 39 cm ·  x 24 LÁMINAS SURTIDAS - Assortment of sheets - Lames assorties - Lâminas sortidas - Lamine assortite

CHOCOLATE

Chocolate · Chocolat · Cioccolato



427630

Negro - Dark - Noir - Preto - Nero
Ø 9 x 5 cm ·  63 u.



427007

Negro - Dark - Noir - Preto - Nero
4,6 x H: 2,6 cm ·  210 u.



427008

Negro - Dark - Noir - Preto - Nero
4,6 x H: 2,6 cm ·  210 u.



427715

6 x 3 cm ·  60 u.



427739

Negro - Dark - Noir - Preto - Nero
4,6 x H: 2,6 cm ·  210 u.



428110

Negro - Dark - Noir - Preto - Nero
5,4 x 2,9 cm ·  60 u.



427011

Negro - Dark - Noir - Preto - Nero
4,6 x H: 2,6 cm ·  210 u.



428097

Negro - Dark - Noir - Preto - Nero
4,6 x H: 2,6 cm ·  90 u.



PERSONALIZACIÓN DE CHOCOLATE

Promociona tu empresa o marca de una forma exclusiva y dulce



CHOCOLATE PERSONALIZED

Promote your company or brand in an exclusive and sweet way

PERSONNALISATIONS CHOCOLAT

Faites la promotion de votre entreprise ou de votre marque de manière exclusive et douce

PERSONALIZAÇÕES CHOCOLATE

Promova sua empresa ou marca de forma exclusiva e doce

PERSONALIZZAZIONI CIOCCOLATO

Promuovi la tua azienda o il tuo marchio in modo esclusivo e dolce



CÓMO HACER TU PEDIDO

1. Elige el formato de letrero, el tipo de chocolate y el color de la tinta.
2. Selecciona la cantidad de cajas.
3. Envíanos por email el diseño en jpg o tiff en alta resolución.

CHOCOLATE

Chocolate · Chocolat · Cioccolato



HOW TO PLACE YOUR ORDER

1. Choose the sign format, the type of chocolate, and the color of the ink.
2. Select the number of boxes.
3. Send us the design in jpg or tiff in high resolution by email.

COMMENT PASSER VOTRE COMMANDE

1. Choisissez le format du signe, le type de chocolat et la couleur de l'encre.
2. Sélectionnez le nombre de cases.
3. Envoyez-nous le design en jpg ou tiff en haute résolution par email.

COMO FAZER SEU PEDIDO

1. Escolha o formato do sinal, o tipo de chocolate e a cor da tinta.
2. Seleccione o número de caixas.
3. Envie-nos o desenho em jpg ou tiff em alta resolução por e-mail.

COME EFFETTUARE L'ORDINE

1. Scegli il formato del segno, il tipo di cioccolato e il colore dell'inchiostro.
2. Selezionare il numero di caselle.
3. Inviaci il disegno in jpg o tiff in alta risoluzione via email.

1 MOLDES TERMOFORMADOS



Molde termoformado de plástico, con la forma elegida, para que pueda crear su propia chocolatina personalizada.



1_FORMATO

Caja de 60 de blisters de 17 x 29 cm.
El nº de chocolatinas, dependerá del formato elegido.

2_PEDIDO MÍNIMO

1 caja.

3_TINTA LOGO

1, 2 ó 3 colores máximo.

4_CLICHÉ

Solo se paga la primera vez.

Cliché gratis en pedidos mínimos:

- 1 tinta: 3 cajas
- 2 tintas: 4 cajas
- 3 tintas: 8 cajas



THERMOFORMED MOLDS · MOULES THERMOFORMÉS · STAMPI TERMOFORMATI

EN: Thermoformed plastic mold, with the chosen shape, so you can create your own personalized chocolate bar. 1.FORMAT: Box of 60 17x29cm blisters. The number of chocolates will depend on the chosen format. 2.MINIMUM ORDER: 1 Box. 3.LOGO INK: 1, 2, or 3 colors maximum. 4.CLICHÉ: You only pay the first time. Free cliché on minimum orders: 1 ink-3 boxes, 2 inks-4 boxes, 3 inks-8 boxes. / FR: Moule en plastique thermoformé, à la forme choisie, pour créer votre propre tablette de chocolat personnalisée. 1.FORMAT : Carton de 60 blisters 17x29cm. Le nombre de chocolats dépendra du format choisi. 2.COMMANDE MINIMUM : 1 Boîte. 3.ENCRES LOGO : 1, 2 ou 3 couleurs maximum. 4.CLICHÉ : Vous ne payez que la première fois. Cliché gratuit sur commande minimum : 1 encre-3 boîtes, 2 encres-4 boîtes, 3 encres-8 boîtes. / PT: Molde de plástico termoformado, com a forma que desejar, para que possa criar a sua própria barra de chocolate personalizada. 1.FORMATO: Caixa com 60 blisters 17x29cm. A quantidade de bombons vai depender do formato escolhido. 2.PEDIDO MÍNIMO: 1 Caixa. 3. TINTA DE LOGO: 1, 2 ou 3 cores no máximo. 4.CLICHÉ: Você só paga na primeira vez. Cliché grátis em pedidos mínimos: 1 tinta-3 caixas, 2 tintas-4 caixas, 3 tintas-8 caixas. / IT: Stampo in plastica termoformato, con la forma prescelta, così potrai creare la tua tavoletta di cioccolato personalizzata. 1.FORMATO: Scatola da 60 blister 17x29cm. Il numero di cioccolatini dipenderà dal formato scelto. 2. ORDINE MINIMO: 1 scatola. 3.LOGO INK: 1, 2 o 3 colori massimo. 4.CLICKÉ: Paghi solo la prima volta. Cliché gratis su ordini minimi: 1 inchiostro-3 scatole, 2 inchiostri-4 scatole, 3 inchiostri-8 scatole.

2 | LETREROS DE CHOCOLATE

REF. 427012

Dinos el tamaño, forma y el tipo de chocolate que prefieres. Envíanos tu logotipo o texto que quieras incluir y... ¡listo!



1_TIPO DE CHOCOLATE



2_PEDIDO MÍNIMO

5 paquetes.

Nº de piezas por caja dependiendo del formato.

3_TINTA LOGO

1, 2 ó 3 colores máximo.

4_CLICHÉ

Solo se paga la primera vez.

Cliché gratis en pedidos mínimos:

- 1 tinta: 20 cajas
- 2 tintas: 32 cajas
- 3 tintas: 64 cajas



PLATES · PLAQUES · TARGUETTE · PLACAS

EN: Tell us the size, shape and type of chocolate you prefer. Send us your logo or text that you want to include and... that's it! 1. TYPE OF CHOCOLATE: MILK, WHITE, DARK. 2. MINIMUM ORDER: 5 packages. Number of pieces per box depending on the format. 3. LOGO INK: 1, 2, or 3 colors maximum. 4. CLICHE: You only pay the first time. Free cliché on minimum orders: 1 ink: 20 boxes, 2 inks: 32 boxes, 3 inks: 64 boxes. FR: Choisissez la taille, la forme et le type de chocolat que vous préférez. Envoyez-nous votre logo ou le texte que vous souhaitez inclure et... c'est tout ! 1. TYPE DE CHOCOLAT : AU LAIT, BLANC, NOIR. 2. COMMANDE MINIMUM : 5 colis. Nombre de pièces par carton selon format. 3. ENCRE DE LOGO : 1, 2 ou 3 couleurs maximum. 4. CLICHE : Vous ne payez quela première fois. Cliché gratuit sur commande minimum : 1 encre : 20 boîtes, 2 encres : 32 boîtes, 3 encres : 64 boîtes. / PT: Diga-nos o tamanho, a forma e o tipo de chocolate que prefere. Envie-nos o seu logótipo ou texto que pretende incluir e... já está! 1. TIPO DE CHOCOLATE: LEITE, BRANCO, PRETO. 2. PEDIDO MÍNIMO: 5 embalagens. Número de peças por caixa em função do formato. 3. TINTA LOGO: 1, 2 ou 3 cores no máximo. 4. CLICHE: Você só paga a primeira vez. Cliché grátis em pedidos mínimos: 1 tinta: 20 caixas, 2 tintas: 32 caixas, 3 tintas: 64 caixas. / IT: Dicci la dimensione, la forma e il tipo di cioccolato che preferisci. Inviaci il tuo logo o testo che vuoi includere e... il gioco è fatto! 1. TIPO DI CIOCCOLATO: LATTE, BIANCO, FONDATE. 2. ORDINE MINIMO: 5 confezioni. Numero di pezzi per scatola a seconda del formato. 3. LOGO INK: 1, 2 o 3 colori massimo. 4. CLICHE: Paghi solo la prima volta. Cliché gratis su ordini minimi: 1 inchiostro: 20 scatole, 2 inchiostri: 32 scatole, 3 inchiostri: 64 scatole.

CHOCOLATE

Chocolate · Chocolat · Cioccolato



FORMATO	MEDIDAS	UDS. ENVASE NORMAL
F17S	Ø 2,4 cm	462 u
F1S	Ø 3 cm	315 u
F314S	Ø 3,9 cm	168 u
F8S	Ø 5 cm	120 u



Format, Measures, Units normal packaging



FORMATO	MEDIDAS	UDS. ENVASE NORMAL
F17S	Ø 2,4 cm	462 u
F1S	Ø 3 cm	315 u
F314S	Ø 3,9 cm	168 u
F8S	Ø 5 cm	120 u



Format, Measures, Units normal packaging



FORMATO	MEDIDAS	UDS. ENVASE NORMAL
F213	3,5 x 2,2 cm	315 u
F7	4,6 x 2,6 cm	210 u
F10	5,5 x 3,5 cm	140 u
F22	4,2 x 3,6 cm	168 u



Format, Measures, Units normal packaging



FORMATO	MEDIDAS	UDS. ENVASE NORMAL
F162S	3,8 x 1,5 cm	392 u
F5S	3,8 x 2,4 cm	294 u
F210S	4 x 2,6 cm	294 u
F125S	5,4 x 2,9 cm	140 u



Format, Measures, Units normal packaging

CHOCOLATE

Chocolate · Chocolat · Cioccolato



F 277 S

FORMATO SURTIDO

Assortment - Assorties

Sortidas - Assortite

2,5 x 1,6 cm · 2 cm · 1,8 x 1,8 cm

Envasado normal: 588 u.



F 278 S

FORMATO SURTIDO

Assortment - Assorties

Sortidas - Assortite

3,7 x 2,4 cm · 2,7 x 2,7 cm · 3 cm

Envasado normal: 315 u.



F 16

4,5 x 4,5 cm

Envasado
normal: 144 u.



F 187

7,2 cm

Envasado
normal: 56 u.



F 285 S

4 cm

Envasado
normal: 196 u.



3 | LÁMINAS SERIGRAFÍA CHOCOLATE

REF. 545200



Obtén tu logo o diseño en láminas de serigrafía para usar directamente sobre chocolate.

1_FORMATO

Caja de 25 láminas de 30 x 40 cm.

VÍDEO



Cómo usar hojas de serigrafía de chocolate:
How to use sheets chocolate screen printing:

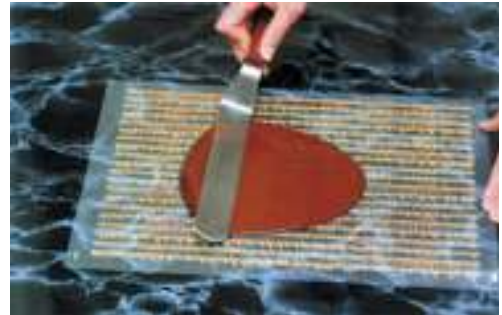

2_PEDIDO MÍNIMO

5 cajas.

3_TINTA LOGO

1, 2 ó 3 colores máximo.

4_CLICHÉ

Solo se paga la primera vez.

Cliché gratis en pedidos mínimos:

- 1 tinta: 20 cajas
- 2 tintas: 32 cajas
- 3 tintas: 64 cajas

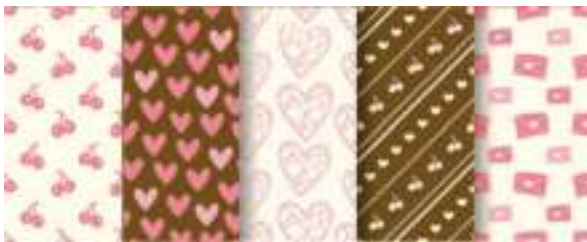

SILK-SCEEN PRINTING · SHEETSLAMES DE SÉRIGRAPHIE · LÂMINAS DE SERIGRAFIA LAMINE DA SERIGRAFIA

EN: Get your logo or design on screen printing sheets to use directly on chocolate. 1.FORMAT: Box of 25 30x40cm sheets. 2. MINIMUM ORDER: 5 boxes. 3.LOGO INK: 1, 2 or 3 colors maximum. 4. CLICHE: You only pay once. Free cliché on minimum orders: 1 ink-20 boxes, 2 inks-32 boxes, 3 inks-64 boxes. / FR: Obtenez votre logo ou dessin sur des feuilles de sérigraphie à utiliser directement sur le chocolat. 1.FORMAT : Carton de 25 feuilles 30x40cm. 2. COMMANDE MINIMUM : 5 boîtes. 3. ENCRE LOGO : 1, 2 ou 3 couleurs maximum. 4. CLICHE : Vous ne payez qu'une seule fois. Cliché gratuit sur commande minimum : 1 encre-20 boîtes, 2 encres-32 boîtes, 3 encres-64 boîtes. / PT: Obtenha seu logotipo ou desenho em folhas de serigrafia para usar diretamente no chocolate. 1.FORMATO: Caixa com 25 folhas de 30x40cm. 2. PEDIDO MÍNIMO: 5 caixas. 3. TINTA LOGO: 1, 2 ou 3 cores no máximo. 4. CLICHE: Você só paga uma vez. Clichê grátis em pedidos mínimos: 1 tinta-20 caixas, 2 tintas-32 caixas, 3 tintas-64 caixas. / IT: Ottieni il tuo logo o disegno su fogli serigrafici da utilizzare direttamente sul cioccolato. 1.FORMATO: Scatola da 25 fogli 30x40cm. 2. ORDINE MINIMO: 5 scatole. 3.LOGO INK: 1, 2 o 3 colori massimo. 4. CLICHE: Paghì solo una volta. Cliché gratis su ordini minimi: 1 inchiostro-20 scatole, 2 inchiostri-32 scatole, 3 inchiostri-64 scatole.

Materia prima y texturizantes

Raw materials and texturizers

Matière première et épaississants

Matéria prima e texturas

Materia prima e testurizzanti



deKora

Special moments

MATERIA PRIMA

Raw materials · Matière première · Matéria prima · Materia prima

CHOCO DRIP

DESCRIPCIÓN: Producto glaseado muy fácil de utilizar para realizar la técnica de decoración conocida como goteo tanto a tartas como semifríos, helados y muchos más productos. **MODO DE USO:** Se extrae el tapón y se introduce en el microondas a 800 W durante aproximadamente 30 segundos. Una vez que se ha calentado, volver a poner el tapón y agitar vigorosamente para mezclar y unificar el producto. Girar la boquilla del tapón para decorar. El producto se solidifica rápidamente y no sigue goteando sobre el pastel para un acabado perfecto. Con tapa dosificadora para que el goteo y la conservación sea perfecta.

EN: DESCRIPTION: Easy to use glaze to decorate, through the technique of dripping, cakes, semifreddi, ice cream, and much more. HOW TO USE: Unscrew the cap and put the bottle in the microwave (800 W) for 30 seconds. After heating, screw the cap and shake vigorously in order to mix well the melted product. Unscrew the nozzle and decorate. The product sets quickly and will not continue to drip over the cake, ensuring a perfect finish. With dosing cap for optimal dripping and preservation.

FR: DESCRIPTION: Produit de glaçage très facile à utiliser pour réaliser la technique de décoration connue sous le nom de goutte-à-goutte aussi bien sur des tartes que des entremets glacés, des glaces et bien d'autres produits. MODE D'EMPLOI: Extraire le bouchon et introduire dans le four micro-ondes à 800 W pendant environ 30 secondes. Une fois chauffé, remettre le bouchon et agiter vigoureusement pour mélanger et unifier le produit. Tourner l'embout du bouchon pour décorer. Le produit se solidifie rapidement et arrête de couler sur le gâteau pour une finition parfaite. Avec un bouchon doseur pour un égouttement et une conservation impeccables.

PT: DESCRIÇÃO: Produto glaseado muito fácil de usar para realizar a técnica de decoração conhecida por "dripping" tanto para tartes como semifrios, gelados e muitos mais produtos. MODO DE UTILIZAÇÃO: Retira-se a tampa e introduz-se no micro-ondas a 800 W durante aproximadamente 30 segundos. Depois de aquecer, volte a colocar a tampa e agite vigorosamente para misturar e unificar o produto. Rode o bocal da tampa para decorar. O produto solidifica rapidamente e não continua a gotejar sobre o bolo para um acabamento perfeito. Com tampa doseadora para que o gotejar e a conservação sejam perfeitos. **IT:** DESCRIZIONE: Prodotto di glassa di facile utilizzo per decorare tramite la tecnica del dripping torte, semifreddi, gelati e molto altro ancora. MODALITÀ D'USO: Svitare il tappo e mettere il flacone nel microonde a 800 W per circa 30 secondi. Una volta riscaldato avvitare il tappo e agitare vigorosamente in modo da miscelare bene il prodotto sciolto. Svitare il beccuccio e procedere alla decorazione. Il prodotto si solidifica rapidamente e non continua a sgocciolare sul dolce, per un effetto perfettamente rifinito. Grazie al tappo dosatore, sia lo sgocciolamento che la conservazione sono perfetti

 180 g ·  1 u.



YouTube



YouTube



MATERIA PRIMA

Raw materials · Matière première · Matéria prima · Materia prima



401030
ROSA
Pink - Rose - Rosa



401031
AZUL
Blue - Bleu
Azul - Blu



401032
AMARILLO
Yellow - Jaune
Amarelo - Giallo



401044
VERDE
Vert - Green - Verde



401029
ROJO CEREZO
Cherry red
Rouge cerise
Vermelho cereja
Rosso ciliegia



401027
CHOCOLATE NEGRO
Dark - Noir
Preto - Nero



401043
ORO ROSA
Rose gold - Or rose
Rosa ouro - Oro rosa



401042
ORO PERLADO
Pearl gold - Perle or -
Ouro perola - Oro perla



401028
CHOCOLATE BLANCO
White - Blanc
Branco - Bianco



MATERIA PRIMA

Raw materials · Matière première · Matéria prima · Materia prima
CREMA DE AZÚCAR · SUGAR CREAM · CRÉME AU SUCRE · CREME DE AÇÚCAR · CREMA DI ZUCCHERO

ROYAL ICING

PASO A PASO

Step by step - Pas à pas - Passo a passo - Passo dopo passo



1



2



3

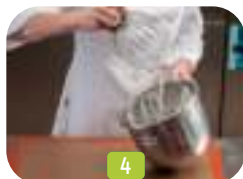

4



5



6



Mezclar durante 10 minutos en la batidora a velocidad 2 sin airear el producto, hasta obtener un glaseado blanco y consistente. **EN:** Instructions: combine for 10 minutes in a mixer set to 2 without aerating the product, until smooth white glaze is obtained. **FR:** Mode d'emploi: mélanger pendant 10 minutes au mixeur, vitesse 2, sans aérer le produit, jusqu'à l'obtention d'un glaçage blanc homogène. **PT:** Modo de aplicação: misturar durante 10 minutos na batedeira, na velocidade 2, sem deixar o produto ao ar, até obter um glacê branco e consistente. **IT:** Mescolare per 10 minuti nel frullatore a velocità 2 senza far prendere aria al prodotto, fino a ottenere una glassa bianca e consistente.

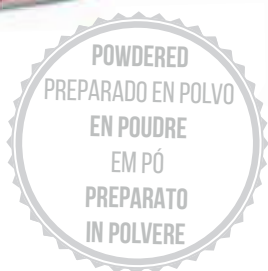

230049

ROYAL ICING

Glasa real · Glaçage royal

Glacé real · Glassa reale

300 g · 4 u.



DOSIS DE USO: consistencia dura, a 300 g de producto añadir 36 ml de agua. Consistencia media, a 300 g de producto añadir 48 ml de agua. Consistencia suave, a 300 g de producto añadir 72 ml de agua.

EN: USES: for a hard consistency, add 36 ml of water to 300 g of product. For a medium consistency, add 48 ml of water to 300 g of product. For a smooth consistency, add 72 ml of water to 300 g of product. **FR:** DOSAGE: pour une consistance dure, ajoutez 36 ml d'eau pour 300 g de produit. Pour une consistance moyenne, ajoutez 48 ml d'eau pour 300 g de produit. Pour une consistance molle, ajoutez 72 ml d'eau pour 300 g de produit. **PT:** DOSE RECOMENDADA: para consistência dura, juntar 36 ml de água a 300 g de produto. Para consistência média, juntar 48 ml de água a 300 g de produto. Para consistência suave, juntar 72 ml de água a 300 g de produto. **IT:** DOSI D'USO: consistenza dura, per 300 g di prodotto aggiungere 36 ml di acqua. Consistenza media, per 300 g di prodotto aggiungere 48 ml di acqua. Consistenza morbida, per 300 g di prodotto aggiungere 72 ml di acqua.

MATERIA PRIMA

Raw materials · Matière première · Matéria prima · Materia prima
CREMA DE AZÚCAR · SUGAR CREAM · CRÈME AU SUCRE · CREME DE AÇÚCAR · CREMA DI ZUCCHERO

FROSTING EN POLVO

In powder · En poudre · Em pó · In polvere



230044
FROSTING CHOCOLATE
Chocolat - Cioccolato
300 g · 4 u.



230046
FROSTING STRAWBERRY
Fresa - Fraise - Morango
Fragola
300 g · 4 u.



230045
FROSTING VANILLA
Vainilla · Vanille · Baunilha
Vaniglia
300 g · 4 u.



Colocar en un bol y mezclar durante 5 minutos / decora a tu gusto pasteles, magdalenas, galletas, bizcochos...

EN: Place in a bowl and mix for 5 minutes / decorate cakes, muffins, cookies and more to your liking. **FR:** Mettre dans un bol puis mélanger pendant 5 minutes / décorez gâteaux, madeleines, biscuits, cakes à votre goût. **PT:** Colocar numa taça e misturar durante 5 minutos / decore ao seu gosto: bolos, queques, bolachas, biscoitos... **IT:** Posizionare in una ciotola e mescolare per 5 minuti / decora come vuoi torte, madeleine, biscotti, ciambelle...

MATERIA PRIMA

Raw materials · Matière première · Matéria prima · Materia prima
 PASTA DE AZÚCAR · SUGAR PASTE · PÂTE À SUCRE · PASTA DE AÇÚCAR · PASTA DI ZUCCHERO

150 g.



x 8u.



NEW

424166
Rojo - Red



NEW

424167
Negro - Black



NEW

424164
Blanco - White



NEW

424168
Azul cielo - Blue



NEW

424165
Rosa - Pink



250 g.



x 6u.



Youtube



424143
Verde - Green



424160
Lila - Purple



424163
Fucsia - Fuchsia



424145
Amarillo - Yellow



424141
Blanco - White

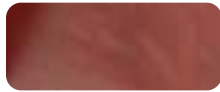

424148
Marrón - Brown



424149
Azul - Dark blue



424162
Naranja - Orange



424144
Negro - Black



424146
Azul - Blue



424142
Rojo - Red



424161
Beige - Nude



424147
Rosa - Pink



1 Kg.



424154
Blanco - White



424156
Rojo - Red



424157
Negro - Black



424158
Azul cielo - Blue



424155
Rosa - Pink



MATERIA PRIMA

Raw materials · Matière première · Matéria prima · Materia prima
 PASTA DE AZÚCAR · SUGAR PASTE · PÂTE À SUCRE · PASTA DE AÇÚCAR · PASTA DI ZUCCHERO



100 g

424159
FONDANT PACK
 100 g x 6 · 1 u.



424123
PASTA DE AZÚCAR MOLDEABLE COLOR NATURAL
 Natural color shapeable sugar paste
 Pâte de sucre qu'on peut mouler
 Pasta de açúcar moldável cor natural
 Pasta di zucchero modellabile colore naturale
 3 kg



424041
PASTA DE AZÚCAR MOLDEABLE BLANCA
 White shapeable sugar paste
 Pâte de sucre qu'on peut mouler blanc
 Pasta de açúcar moldável branco
 Pasta di zucchero modellabile bianca
 1 kg



PEGAMENTO COMESTIBLE

Edible glue · Colle comestible · Cola comestível · Adesivo commestibile



410016
PEGAMENTO COMESTIBLE
 6 x 40 g



Perfecto para pegar pasta de azúcar.

- Ideal for adhering the sugar paste.
- Idéal pour coller la pâte de sucre.
- Perfeito para colar pasta de açúcar.
- Perfetto per incollare la pasta di zucchero

CMC EN POLVO



424079
 Powder - Poudre
 Pó - Polvere
 4 x 40 g



MATERIA PRIMA

Raw materials · Matière première · Matéria prima · Materia prima



LACA EN SPRAY BRILLO

Spray brightness lacquer
Laque en spray éclat
Laca em spray brilho
Lacca spray brillante

430073

 300 ml



Ideal para proteger y dar brillo a productos a base de azúcar o chocolate. Se recomienda rociar la superficie a ser decorada con pequeñas pulsaciones. Agitar bien antes de usar.

EN: Ideal to protect surfaces sugar based or chocolate. It is recommended to spray the surface to be decorated with small pulsations. Shake well before using. **FR:** Pour protéger et donner briller à surfaces à base de sucre ou de chocolat. Vaporiser la surface à décorer avec de petites pulsations. Bien agiter avant utilisation. **PT:** Para proteger e dar brilho a produtos de açúcar com base ou chocolate. Pulverize a superfície a ser decorada com pequenas pulsações. Agitar bem antes de utilizar. **IT:** Ideale per proteggere e donare lucentezza ai prodotti a base di zucchero o cioccolato. Si consiglia di spruzzare la superficie da decorare con lievi pressioni. Agitare bene prima dell'uso



SPRAY DESMOLDANTE

Spray bake non-stick
Anti-adhésif en spray
Desmoldante em spray
Spray sformante

430005

 400 ml



Producto para desmoldar: chocolate, fondant, pan, tartas, etc.

EN: Product to release foodstuff preparations from baking pan and mould, etc. **FR:** Produit destiné à libérer les préparations alimentaires du moule et des moules, etc. **PT:** Produto para desenformar: chocolate, fondant, pão, tortas, etc. **IT:** Prodotto per sformare: cioccolato, fondant, pane, torte, ecc.



FRÍO GEL

Cold gel - Froid gel -
Frio gel - Gel freddo

430025

 400 ml



Cánula larga para un uso preciso.

EN: Long nozzle for precise dispensing

Frío para pegar piezas artísticas de chocolate y caramelo.

EN: Cold to stick artistic pieces of chocolate and caramel. **FR:** Froid pour coller des morceaux artistiques de chocolat et de caramel. **PT:** Frio para colar pedaços artísticos de chocolate e caramelo. **IT:** Freddo per incollare elementi artistici in cioccolato e caramello.

MATERIA PRIMA

Raw materials · Matière première · Matéria prima · Materia prima

GELATINA EN SPRAY

Gelatina spray · Gélatine en spray · Gelatina spray · Gélatine en spray



430078

200 ml



Gelatina en spray para la decoración de productos alimentarios, en particular para pasteles y tartas. Pulverizar una capa homogénea de producto sobre la superficie a decorar desde una distancia de unos 20-25 cm.

EN: Product for the decoration of food, in particular of pastries and cakes. Spray homogeneous layer of product on the food to be decorated from a distance of about 20-25 cm.

Resto de idiomas, consultar la web / Consulter les langues sur le site web / Consultar idiomas na web / Per le lingue disponibili consultare il sito web.



403005

GELATINA EN HOJAS FINAS CALIDAD ORO

Gelatine sheets gold quality - Gélatine en feuilles fines qualité or - Gelatina em folhas finas qualidade oro - Gelatina in fogli sottili di qualità oro

1 kg



deKora

YouTube

Escanea este código QR

EN: Scan this QR code.
FR: Scannez ce code QR.
PT: Digitalize este código QR.
IT: Scannerizza questo codice QR

403013

GELATINA EN POLVO CALIDAD ORO

Powdered gelatine gold quality
Gélatine en poudre fines qualité or
Gelatina em pó qualidade oro
Gelatina in polvere di qualità oro

1 kg



424031

GEL DE SÍLICE

Silica gel
Gel di silice

100 x 5 g



ÁCIDOS

Acids · Acides · Ácidos · Acidi



410017

ÁCIDO CÍTRICO

Citric acid - Acide citrique - Ácido cítrico - Acido citrico

400 g



Propiedades: Regulador de la acidez y conservador.
Modo de uso: Directamente sobre el producto y remover.
Aplicación: Controla la acidez o alcalinidad de un producto alimenticio.
Solubilidad: Soluble en líquidos.
Dosificación: 1-10 g/ kg según aplicación.
Elaboraciones: En golosinas, mermeladas, frutas, gelatinas, etc.

EN: Properties: Acidity regulator and preservative.
 How to use: Directly in the product and stir.
 Application: Controls the acidity or alkalinity of a food product.
 Solubility: Soluble in liquids.
 Dosage: 1-10 g/kg depending on application.
 Production of: Sweets, jams, fruits, gelatine, etc.



410018

ÁCIDO TARTÁRICO

Tartaric acid - Acide tartrique - Ácido tartárico - Acido tartarico

400 g



Propiedades: Acidulante y conservante natural.
Modo de uso: Directamente sobre el producto y remover.
Aplicación: Prolonga la vida útil de los alimentos protegiéndolos del deterioro causado por microorganismos, incrementan la acidez de un producto alimenticio o le confieren un sabor ácido, o ambas cosas.
Solubilidad: Soluble en líquidos.
Dosificación: 1 g/ kg según aplicación.
Elaboraciones: Como conservante natural para mermeladas, helados, gelatinas, conservas, bebidas. En los mostos y vinos se emplea para elaborar vinos más equilibrados desde el punto de vista gustativo.

EN: Properties: Acidulant and natural preservative.
 How to use: Directly in the product and stir.
 Application: Prolongs a food's shelf life by protecting it from the deterioration caused by microorganisms, and increases the acidity of a food product or gives it an acidic flavour, or both.
 Solubility: Soluble in liquids.
 Dosage: 1 g/kg depending on application.
 Production of: As a natural preservative in jams, ice creams, gelatine, preserves, drinks. In musts and wines it is used to produce wines that are more balanced in terms of their taste.

TEXTURIZANTES

Texturizers · Épaississants · Texturas · Testurizzanti



410019

ÁCIDO ASCÓRBICO

Ascorbic acid - Acide ascorbique -
Ácido ascórbico - Acido ascorbico

 400 g



Propiedades: Conservador, acidulante y antioxidante.

Modo de uso: Directamente sobre el producto y remover.

Aplicación: Prolonga la vida útil de los alimentos protegiéndolos del deterioro causado por la oxidación, incrementan la acidez de un producto alimenticio o le confieren un sabor ácido, o ambas cosas. prolongan la vida útil de los alimentos protegiéndolos del deterioro causado por microorganismos o que protegen del crecimiento de microorganismos patógenos.

Solubilidad: Soluble en líquidos.

Dosificación: 0,05 g/l según aplicación.

Elaboraciones: En golosinas, mermeladas, frutas, gelatinas, etc

EN: Properties: Preservative, acidulant and antioxidant. How to use: Directly in the product and stir.

Application: Prolongs a food's shelf life by protecting it from the deterioration caused by oxidation, and increases the acidity of a food product or gives it an acidic flavour, or both. Prolongs a food's shelf life by protecting it from the deterioration caused by microorganisms.

Solubility: Soluble in liquids.

Dosage: 0,05 g/l depending on application.

Production of: Mix where oxidation needs to be avoided, fruit salads, juices, etc.

ESPEANTES

Thickening agents · Épaississants · Espessantes · Addensanti



410022

GOMA GUAR

Guar gum - Gomme de guar -
Goma de guar - Gomma guar

 300 g



Propiedades: Espesante.

Modo de uso: Se presenta en forma de polvo que diluiremos en agua (ya sea fría o caliente) para obtener una salsa o una sopa espesa.

Aplicación: Sustancia que aumenta la viscosidad de un alimento.

Solubilidad: Soluble en líquidos fríos o calientes.

Dosificación: 3-5 g/kg según aplicación.

Elaboraciones: Helados, repostería y salsas.

EN: Properties: Thickener.

How to use: It comes in powder form that we will dilute in water (either hot or cold)

Application: substance that increases a food's viscosity.

Solubility: Completely soluble in hot water.

Dosage: 3-5 g/kg depending on application.

Production of: Ice cream, baking and sauces.

Resto de idiomas, consultar la web / Consulter les langues sur le site web / Consultar idiomas na web / Per la lingue disponibili consultare il sito web.

TEXTURIZANTES

Texturizers · Épaississants · Texturas · Testurizzanti



410023

GOMA ARÁBIGA

Gum arabic - Gomme d'arabiga
Goma-arábica - Gomma arabica

 300 g



Propiedades: Espesante.

Modo de uso: Se presenta en forma de polvo que diluiremos en agua ya sea fría o caliente.

Aplicación: Sustancia que aumenta la viscosidad de un alimento.

Solubilidad: Soluble en líquidos fríos o calientes.

Dosificación: 2-10 g/ kg según aplicación.

Elaboraciones: Gominolas, marshmallows, repostería y confitería.

EN: Properties: Thickener.

How to use: It comes in powder form that we will dilute in water (either hot or cold)

Application: Substance that increases a food's viscosity.

Solubility: Completely soluble in hot water.

Dosage: 2-10 g/kg depending on application.

Production of: Jellybeans, marshmallows, pastries and confectionery.



410025

GOMA XANTANA

Xanthan gum - Gomme xhantane
Goma xantana - Gomma di xantano

 300 g



Propiedades: Espesante.

Modo de uso: Se presenta en forma de polvo que diluiremos en agua ya sea fría o caliente.

Aplicación: Sustancia que aumenta la viscosidad de un alimento.

Solubilidad: Soluble en líquidos fríos o calientes.

Dosificación: 2-10 g/kg según aplicación.

Elaboraciones: Rellenos para pastelerías, emulsiones saborizantes, aderezos, productos lácteos, salsas, confitería, jarabes, etc.

EN: Properties: Thickener.

How to use: It comes in powder form that we will dilute in water (either hot or cold).

Application: Substance that increases a food's viscosity.

Solubility: Completely soluble in hot water.

Dosage: 2-10 g/kg depending on application.

Production of: Fillings for cakes, flavour emulsions, dressings, dairy products, sauces, confectionery, syrups, etc.

Resto de idiomas, consultar la web / Consulter les langues sur le site web / Consultar idiomas na web / Per le lingue disponibili consultare il sito web.

TEXTURIZANTES

Texturizers · Épaississants · Texturas · Testurizzanti

GELIFICANTES

Gelling agents · Gélifiants · Gelificantes · Gelificanti



410020
ALGINATO
Alginate - Alginate - Alginate
300 g



Propiedades: Gelificante/espesante. **Modo de uso:** Aplicar directamente sobre el producto y mezclar bien con la ayuda de un batidor eléctrico para homogeneizar bien la mezcla. **Aplicación:** Sustancia que da textura a un producto alimenticio mediante la formación de un gel / Sustancia que aumenta la viscosidad de un alimento. **Indicaciones:** actúa como gelificante cuando interactúa con medios cálcicos. En helados ayuda a controlar la formación de cristales de hielo, aumenta el volumen y retarda el descongelamiento, además de ofrecer una sensación suave y tersa en boca. **Solubilidad:** Soluble en líquidos. **Dosificación:** 5 g/ Kg **Elaboraciones:** Esferificación, espumas, aires, espesados, geles irreversibles en agua fría.

EN: Properties: Gelling/thickener. Apply directly to the product and mix well with the help of an electric hand mixer to thoroughly mix the mixture. Application: Substance that gives a food product texture by forming a gel / Substance that increases a food's viscosity. Indications: Acts as a gelling agent when it interacts with calcium means. In ice cream it helps to control the formation of ice crystals, increases the volume and delays defrosting, besides offering a soft and smooth sensation in the mouth. Solubility: Soluble in liquids. Dosage: 5 g/kg Production of: Spherification, foams, air, thickening, irreversible gels in cold water.



410024
PECTINA LM
300 g



Pectina LM (bajo metoxilo) forma geles untantes, brillantes y confieren al gel características de elevada untabilidad y brillante, son termo-reversibles tanto en caliente como en frío. Para elaboraciones con concentraciones de azúcar (sacarosa) muy altas, se debe trabajar con un PH inferior a 3,5 pues de lo contrario el producto tiende a empanizarse (granillo blanquecino) Para evitar la empanización se recomienda trabajar con pH 3,2 a ácido a la mezcla por ejemplo ácido cítrico. **Modo de uso:** Mezclar bien la pectina con el azúcar y con la mermelada a fuego lento hasta conseguir la textura deseada. Las mermeladas necesitan un ácido para gelificar mejor, por lo tanto es importante añadir un ácido a la mezcla, por ejemplo, ácido cítrico. **Aplicación:** Sustancia que da textura a un producto alimenticio mediante la formación de un gel. **Solubilidad:** Soluble en líquidos llevados a ebullición. **Dosificación:** 15 g/kg de pulpa. **Elaboraciones:** Adecuado para la fabricación de gelatinas, productos de pastelería y repostería.

EN: They form glossy, spreadable gels and give the gel characteristics of high spreadability and shine. They are also thermo-reversible in both hot and cold temperatures. To produce using very high sugar (sucrose) concentrations, work with a pH of less than 3.5, to avoid the product having a coated appearance with white granules. To avoid the coating, it is recommended to work within a pH range of 3.2 - 3.5 or failing that at pH 3.5. Properties: gelling. How to use: Mix the pectin well with the sugar and mix with the jam over low heat until the desired texture is achieved. The jams need an acid for a greater gelation so it is important to add an acid such as citric acid to the mixture. Application: Substance that gives a food product texture by forming a gel. Solubility: Soluble in liquids brought to the boil. Dosage: 15 g/kg of pulp. Production of: Suitable for the production of gelatine, bakery and confectionary products.

Resto de idiomas, consultar la web / Consulter les langues sur le site web / Consultar idiomas na web / Per le lingue disponibili consultare il sito web.

TEXTURIZANTES

Texturizers · Épaississants · Texturas · Testurizzanti

UTENSILIOS · TOOLS · OUTILLAGE · UTENSÍLIOS



** 100 ml mezcla
Mixture / Mélange



Cazo
Saucepan



Ref: 410021
1 g Ágar ágar



Aceite vegetal
Vegetable oil / Huile végétale / Azeite vegetal



Ref: 535003



Ref: 535330



Agua de botella
Bottle water / Eau en bouteille / Água da garrafa



** **ES.** Zumo de frutos rojos (elegir la mezcla líquida a esferificar al gusto pH ≥ 3). **EN.** Red berries juice (choose the liquid mixture to spherify to your liking pH ≥ 3). **FR.** Jus de fruits rouges (choisir le mélange liquide à sphérifier selon votre goût pH ≥ 3). **PT.** Sumo de frutos vermelhos (escolher a mistura líquida a esferificar conforme o gosto pH ≥ 3). **IT.** Succo di frutti rossi (scegliere la miscela liquida ed effettuare la sferificazione a proprio gusto pH ≥ 3).

PASO A PASO · STEP BY STEP · PAS À PAS · PASSO A PASSO

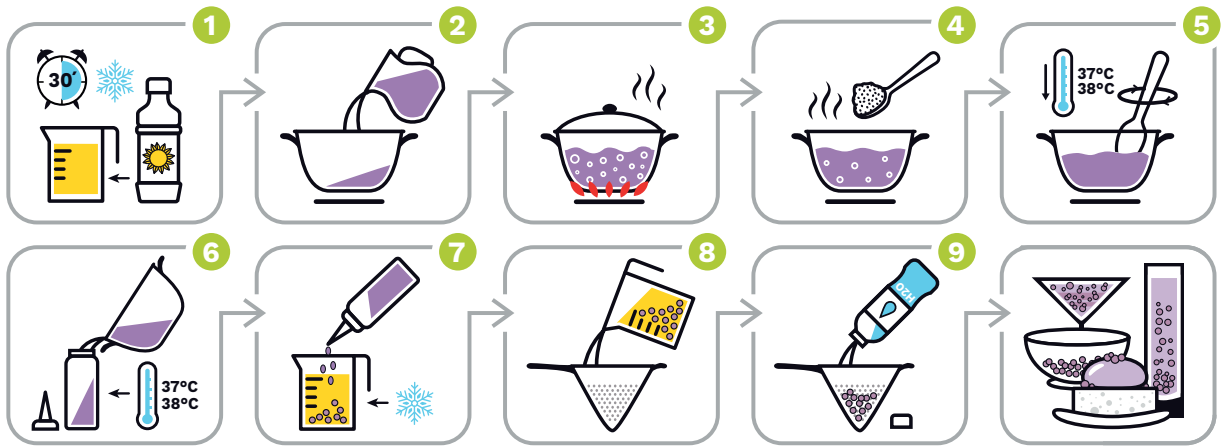

1 **ES.** Congelar o refrigerar durante 30' previamente. **EN.** reeze or refrigerate for 30' beforehand. **FR.** Congeler ou placer préalablement au réfrigérateur durant 30'. **PT.** Congelar ou refrigerar durante 30 segundos antes. **IT.** Surgelare o conservare refrigerato 30' prima. 2 **ES.** Mezcla el producto a esferificar (elegir al gusto). **EN.** Mix or product to spherify (choose to your liking). **FR.** Mélange ou produit à sphérifier (au choix). **PT.** Mistura ou produto a esferificar (escolher conforme o gosto). **IT.** Miscelare il prodotto da sterificare (scegliere a proprio gusto) 3 **ES.** Llevar a ebullición. **EN.** Bring to the boil. **FR.** Porter à ébullition. **PT.** Deixar ferver. **IT.** Portare a ebollizione. 4 **ES.** Añadir 1 g ágar ágar. **EN.** To add 1 g ágar ágar. **FR.** Ajouter 1 g ágar ágar. **PT.** Adicionar 1 g ágar ágar. **IT.** Aggiungere 1 g di ágar ágar. 5 **ES.** Remover bien, una vez el producto este integrado, dejar reposar hasta conseguir 37–38°C. **EN.** Stir well, once the product is integrated, let it rest until you get 37–38°C. **FR.** Une fois le produit ajouté, bien remuer, laisser reposer jusqu'à obtenir 37–38°C. **PT.** Remover bem, uma vez que o produto está impregnado, deixar repousar até conseguir 37–38°C. **IT.** Mescolare con attenzione, una volta ben miscelato il prodotto, lasciar riposare fino a condurre a una temperatura pari a 37–38°C 6 **ES.** Verter la mezcla a 37–38°C. **EN.** Pour the mixture at 37–38°C. **FR.** Verser le mélange à 37–38°C. **PT.** Derramar a mistura a 37–38°C. **IT.** Versare la miscela a 37–38°C 7 **ES.** dejar caer gotitas lentamente. **EN.** drop droplets slowly. **FR.** faire tomber doucement des gouttelettes. **PT.** deixar cair pequenas gotas lentamente. **IT.** Far gocciolare lentamente. 8 **ES.** Colar el contenido de la jarra. **EN.** Strain the contents of the jar. **FR.** Filtrer le contenu du récipient. **PT.** Colar o conteúdo da jarra. **IT.** Scolare il contenuto della brocca. 9 **ES.** Enjuagar con agua de botella. **EN.** Rinse with bottled water. **FR.** Rincer à l'aide d'eau en bouteille. **PT.** Enxaguar com água da garrafa. **IT.** Risciacquare la bottiglia con acqua

RECOMENDACIONES · RECOMMENDATIONS · CONSEILS · RECOMENDAÇÕES · RACCOMANDAZIONI

ES. Usar siempre un recipiente alto para dejar caer las gotitas. **EN.** Always use a tall container for the drops to fall into. **FR.** Toujours utiliser un récipient haut pour laisser tomber les gouttelettes. **PT.** Utilizar sempre um recipiente alto para deixar cair as gotinhas. **IT.** Servirsi sempre di un recipiente alto per lo sgocciolamento. **ES.** Para mezclas dulces, se recomienda usar aceite de girasol, para que no adquieran sabor. Estas perlas se pueden usar para diversas elaboraciones, como decorar tartas, acompañar platos, salsas, incluso dentro de algún coctel, o ensaladas. **EN.** For sweet mixtures, it is recommended to use sunflower oil, so that they do not acquire flavour. These pearls can be used for various preparations, such as decorating cakes, accompanying dishes, sauces, even in a cocktail, or salads. **FR.** Pour des mélanges sucrés, il est conseillé d'utiliser de l'huile de tournesol, afin d'éviter qu'elle prennent le goût des aliments. Ces perles peuvent être utilisées dans différentes recettes, en guise de décoration pour les pâtisseries, pour accompagner plats et sauces, et même dans un cocktail ou des salades. **PT.** Para misturas doces, recomenda-se utilizar óleo de girassol, para que não adquiram sabor. Estes pérolas podem ser utilizadas em várias elaborações, como decorar tartes, acompanhar pratos, molhos, inclusive dentro de cocktails ou saladas. **IT.** Per miscele dolci, si consiglia di utilizzare l'olio di girasole per non alterare sapore al prodotto. Queste perle possono essere utilizzate in diverse lavorazioni, per esempio per la decorazione di torte e piatti, salse e persino all'interno di alcuni cocktail o insalate.

TEXTURIZANTES

Texturizers · Épaississants · Texturas · Testurizzanti



410021

ÁGAR - ÁGAR

 400 g



Propiedades: Gelificante.

Modo de uso: El agar-agar al estar en polvo, se debe de mezclar con la preparación que deseemos espesar y/o gelificar y disolvemos en un líquido para que pueda empezar a funcionar.

Aplicación: Sustancia que da textura a un producto alimenticio mediante la formación de un gel.

Solubilidad: Soluble en agua en ebullición.

Dosificación: 1-10 g/kg según aplicación.

Elaboraciones: En golosinas, mermeladas, frutas, gelatinas, etc.

EN: Properties: Gelling. How to use: When agar-agar is a powder, it must be mixed with the preparation we want to thicken and/or gel, and dissolve it in a liquid so that it can begin to take effect. Application: Substance that gives a food product texture by forming a gel. Solubility: Soluble in boiling water. Dosage: 1-10 g/kg depending on application. Production of: Sweets, jams, fruits, gelatine, etc. **FR:** Propriétés: Gélifiant. Mode d'utilisation: L'agar-agar étant en poudre, il doit être mélangé à la préparation que nous souhaitons épaissir et/ou gélifier, et nous le dissolvons en liquide pour pouvoir commencer à fonctionner. Application: Substance qui apporte de la texture à un produit alimentaire par la formation d'un gel. Solubilité: Soluble dans de l'eau en ébullition. Dosage: 1-10 g/kg selon l'application. Elaborations: Dans des bonbons, des confitures, des fruits, des gélatines, etc. **PT:** Propriedades: Gelificante. Modo de utilização: O ágar-ágar ao estar em pó, deve ser misturado com a preparação que queremos espessar e/ou gelificar e dissolvemos num líquido para que possa começar a funcionar. Aplicação: Substância que dá textura a um produto alimentar através da formação de um gel. Solubilidade: Solúvel em água em ebulição. Dosagem: 1-10 g/kg, dependendo da aplicação. Elaborações: Em doces, compotas, frutas, gelatinas, etc. **IT:** Proprietà: Gelificante. Modalità d'uso: L'agar-agar si presenta in polvere e deve essere dunque miscelato con il preparato da addensare e/o gelificare, dissolvendolo in un liquido perché possa iniziare a funzionare. Applicazione: Sostanza che migliora la consistenza degli alimenti attraverso la formazione di un gel. Solubilità: Solubile in acqua bollente. Dosaggio: 1-10 g/kg a seconda dell'applicazione. Elaborazioni: Caramelle, marmellate, frutta, gelatine, ecc.

AZÚCARES GRANULADOS

Granulated sugars · Sucres granulés · Açúcares granulados · Zuccheri granulati



424138
FRUCTOSA
 Fructose - Fruttosio
 400 g



Propiedades: Edulcorante.

Modo de uso: Aplicar directamente sobre el producto y remover.

Aplicación: Sustancia que se emplea para dar sabor dulce a los alimentos.

Solubilidad: Soluble en líquidos.

Elaboraciones: Repostería, confitería, golosinas, etc (a cualquier producto que se quiera endulzar).

EN: Properties: Sweetener

How to use: Apply directly in the product and stir.

Application: Substance that is used to give food a sweet flavour.

Solubility: Soluble in liquids.

Production of: pastries, confectionary products, sweets... etc. (any product that you want to sweeten).

FR: Propriétés: Édulcorant.

Mode d'utilisation: Appliquer directement sur le produit et retirer.

Application: Substance utilisée pour donner un goût sucré aux aliments.

Solubilité: Solubilité en liquides.

Élaborations: Pâtisserie, confiserie, bonbons, etc. (à n'importe quel produit que l'on souhaite sucrer).

PT: Propriedades: Edulcorante.

Modo de utilização: Aplicar diretamente no produto e remover.

Aplicação: Substância que é usada para dar um sabor doce aos alimentos.

Solubilidade: Solúvel em líquidos a ferver.

Elaborações: Pastelaria, confeitaria, doces, etc.(para qualquer produto que se queira adoçar).

IT: Proprietà: Edulcorante.

Modalità d'uso: Applicare direttamente sul prodotto e mescolare.

Applicazione: Sostanza che conferisce un sapore dolce agli alimenti.

Solubilità: Solubile nei liquidi

Elaboraciones: pasticceria, confetteria, caramelle, ecc.

(comprende qualsiasi prodotto si desideri addolcire)



424034
GLUCOSA 44
 Glucose - Glicose
 Glucosio
 5 kg



Modo de uso: Aplicar directamente sobre el producto y remover.

Aplicación: Sustancia que se emplea para dar sabor dulce a los alimentos.

Solubilidad: Soluble en líquidos.

Elaboraciones: Repostería, confitería, golosinas, etc (a cualquier producto que se quiera endulzar)

EN: How to use: Apply directly in the product and stir. Application: Substance that is used to give food a sweet flavour. Solubility: Soluble in liquids. Production of: Pastries, confectionary products, sweets... etc. (any product that you want to sweeten).

FR: Mode d'utilisation: Appliquer directement sur le produit et retirer. Application: Substance utilisée pour donner un goût sucré aux aliments. Solubilité: Solubilité en liquides. Élaborations: Pâtisserie, confiserie, bonbons, etc. (à n'importe quel produit que l'on souhaite sucrer).

PT: Modo de utilização: Aplicar diretamente no produto e remover. Aplicação: Substância que é usada para dar um sabor doce aos alimentos. Solubilidade: Solúvel em líquidos. Elaborações: Pastelaria, confeitaria, doces, etc.(para qualquer produto que se queira adoçar).

IT: Modalità d'uso: Applicare direttamente sul prodotto e mescolare. Applicazione: sostanza che conferisce un sapore dolce agli alimenti. Solubilità: Solubile nei liquidi. Lavorazioni: pasticceria, confetteria, caramelle, ecc. (comprende qualsiasi prodotto si desideri addolcire)

TEXTURIZANTES

Texturizers · Épaississants · Texturas · Testurizzanti



deKora

YouTube



424032

ISOMALT TEXTURA GRUESA

Thick texture - Texture grosse - Textura grossa - Isomalt consistenza grossa

5 kg



Propiedades: Edulcorante.

Modo de uso: Aplicar directamente sobre el producto y remover.

Aplicación: Para trabajos de caramelo, utilizar directamente, dejar alcanzar textura deseada. Admite colorantes líquidos y en polvo.

Solubilidad: Soluble en líquidos.

Elaboraciones: Decoraciones caramelo, figuras caramelo, caramelo soplado.

EN: Properties: Sweetener. How to use: Apply directly in the product and stir. Application: For sweets, use directly, let them reach desired texture, it can take liquid and powder dyes. Solubility: Soluble in liquids. Production of: Candy decorations, candy figures, blown sugar.

FR: Propriétés: Édulcorant. Mode d'utilisation: Appliquer directement sur le produit et retirer. Application: Pour le travail du caramel, utiliser directement jusqu'à obtention de la texture souhaitée. Admet les colorants liquides et en poudre. Solubilité: Solubilité en liquides. Élaborations: Décorations en caramel, figures en caramel, caramel soufflé.

PT: Propriedades: Edulcorante. Modo de utilização: Aplicar diretamente no produto e remover. Aplicação: Para trabalhos de caramelo, usar diretamente, deixar atingir a textura pretendida, pode levar colorantes líquidos e em pó. Solubilidade: Solúvel em líquidos. Elaboraões: Decorações com caramelo, figuras com caramelo, caramelosoprado.

IT: Proprietà: Edulcorante. Modalità d'uso: Applicare direttamente sul prodotto e mescolare. Applicazione: Per lavorazioni in caramello, utilizzare direttamente, lasciare che il prodotto raggiunga la consistenza desiderata. Compatibile con coloranti liquidi e in polvere. Solubilità: Solubile nei liquidi. Lavorazioni: Decorazioni in caramello, sagome in caramello, caramello soffiato.

AZÚCAR LÍQUIDO INVERTIDO

Invert liquid sugar · Sucre liquide inversi · Açúcar líquido invertido
Zucchero liquido invertito



410026

600 g



Mejora la textura. Proporciona un mejor sabor. Aumenta la vida útil. Facilita la cocción. Mejora la retención de humedad. Estabiliza la masa. Reduce la cristalización. Ayuda a reducir la formación de cristales de hielo. Proporciona una textura más suave. Aumenta la estabilidad. Ayuda a prevenir la resequeidad.

EN: Improves texture. Provides a better taste. Increases the useful life. Makes cooking easier. Improves moisture retention Stabilizes the dough. Reduces crystallization. Helps reduce the formation of ice crystals. Provides a smoother texture Increases stability. Helps prevent dryness.

FR: Améliore la texture. Fournit un meilleur goût. Augmente la durée de vie utile Facilite la cuisson. Améliore la rétention d'humidité Stabilise la pâte. Réduit la cristallisation. Aide à réduire la formation de cristaux de glace. Fournit une texture plus lisse. Augmente la stabilité. Aide à prévenir le dessèchement.

PT: Melhora a textura. Proporciona um sabor melhor Aumenta a vida útil. Torna o cozimento mais fácil. Melhora a retenção de umidade. Estabiliza a massa. Reduz a cristalização. Ajuda a reduzir a formação de cristais de gelo. Proporciona uma textura mais suave. Aumenta a estabilidade. Ajuda a prevenir o ressecamento

IT: Migliora la consistenza. Fornisce un gusto migliore Aumenta la vita utile. Facilita la cottura. Migliora la ritenzione dell'umidità. Stabilizza l'impasto. Riduce la cristallizzazione. Aiuta a ridurre la formazione di cristalli di ghiaccio. Fornisce una consistenza più liscia. Aumenta la stabilità. Aiuta a prevenire la secchezza.

TEXTURIZANTES

Texturizers · Épaississants · Texturas · Testurizzanti

AROMAS EN PASTA

Food flavors in paste · Arômes alimentaires en pâte
Aromas alimentares em pasta · Aromi alimentari in pasta



60 ml ·  x 4 



- Los aromas alimentarios en pasta son ideales para aromatizar bizcochos, cremas, frosting, cupcakes, fondant, galletas.
- Además, también están indicados para preparaciones en frío como helados, batidos, granizados.
- Los aromas en pasta son saborizantes que **APORTAN COLOR** además de sabor a nuestras preparaciones, ya que en su formulación contienen colorantes, excepto el aroma de coco.
- La dosificación de estos aromas es de +/- 4-7 g por kg de masa, se recomienda añadir el aroma en la última fase de preparación de nuestra receta.

EN: Food flavors in paste are ideal for flavoring cakes, creams, frosting, cupcakes, fondant, cookies. They are also suitable for cold preparations such as ice cream, milkshakes, slushies. The paste flavors are flavorings that **ADD COLOR** as well as flavor to our preparations, as they contain colorants in their formulation, except for the coconut flavor. The recommended dosage for these flavors is +/- 4-7 grams per kilogram of dough. It is recommended to add the flavor in the last phase of preparing our recipe.

APTOS PARA VEGANOS:

Suitable for vegans - Convient aux végétaliens - Adequado para veganos - Adatto ai vegani.



410027
NARANJA
Orange



410028
LIMÓN
Lemon



410029
FRESA
Strawberry



410030
FRAMBUESA
Raspberry



410031
RED VELVET
Red velvet



410032
VAINILLA
Vanilla



410033 
COCO
Coconut



410034
VIOLETAS
Violets

Resto de idiomas, consultar la web / Consulter les langues sur le site web / Consultar idiomas na web / Per le lingue disponibili consultare il sito web.

macarons de PARIS

402003

NATURAL, CHOCOLATE, PISTACHO Y FRESA

Natural, chocolate, pistachio and strawberry

Naturel, chocolat, pistache et fraise

Natural, chocolate, pistachio e morango

Naturale, cioccolato, pistacchio e fragola

Ø 3,5 cm · 📦 160 u.



Cómo decorar una torta de cumpleaños / How to decorate a birthday cake / Comment décorer un gâteau d'anniversaire / Como decorar um bolo de aniversário / Come decorare una torta di compleanno



Tronco de chocolate / Chocolate log / Bûche au chocolat / Tronco de chocolate / Tronco di cioccolato





Gama Oro Gourmet

Gourmet Gold Range

UN TOQUE DE LUJO A TUS ELABORACIONES A TOUCH OF LUXURY TO YOUR ELABORATIONS

Todos los productos Orogourmet son comestibles y disponen de los Registros Sanitarios exigidos tanto en la Unión Europea como en Estados Unidos, así como el certificado Kosher de alimentación. **Orogourmet se produce a partir de oro de 24 quilates según la normativa europea.** Tiene múltiples aplicaciones y se funde en el paladar sin alterar el sabor ni aroma natural de los alimentos.

All Orogourmet products are edible and have the Sanitary Registries required both in the European Union and in the United States, as well as the Kosher food certificate. **Orogourmet is produced from 24 carat gold according to European regulations.** It has multiple applications and melts on the palate without altering the natural flavor or aroma of food.



CONFORME
NORMATIVA UE
COMPLIES TO EU
REGULATION



FABRICADO
EN ALEMANIA
MADE IN
GERMANY



CERTIFICADO
KOSHER
KOSHER
CERTIFICATE



IDÓNEO HALAL
HALAL SUITABLE



SIN GLUTEN
GLUTEN FREE



VEGANO
VEGAN



ORO
RESPONSABLE
RESPONSIBLE
GOLD



CERTIFICADO
HACCP
HACCP
CERTIFICATE



FR: VOIR LA VERSION
FRANÇAISE



PT: VER VERSÃO
EM PORTUGUÊS



IT: VEDI VERSIONE
IN ITALIANO

TEXTURIZANTES

Texturizers · Épaississants · Texturas · Testurizzanti

Shabin



401052
SHABIN
ORO/GOLD
1 g

401057
SHABIN
ORO/GOLD
300 mg



401062
SHABIN
PLATA/SILVER
1 g

Filamentos filaments



401055
FILAMENTO FINO ORO
Thin gold filament
300 mg



401056
FILAMENTO GRUESO ORO
Thick gold filament
300 mg



TEXTURIZANTES

texturizers · Épaississants · Texturizantes · Texturizzanti

Polvo powder



401048
POLVO ORO
Gold powder
1 g



401049
POLVO ORO
Gold powder
300 mg

401060
POLVO PLATA
Silver powder
1 g



401066
DOSIFICADOR
METÁLICO POLVO
Stainless Steel
Shaker for powder

Copos flakes



401050
COPOS ORO
Gold flakes
1 g



401051
COPOS ORO
Gold flakes
300 mg

401061
COPOS PLATA
Silver flakes
1 g



401065
DOSIFICADOR
METÁLICO COPOS
Stainless Steel
Shaker for flakes

Quadratus



401053
QUADRATUS ORO
Gold quadratus
300 mg



Corazones hearts



401054
CORAZONES ORO
Gold hearts
300 mg



TEXTURIZANTES

Texturizers · Épaississants · Texturas · Testurizzanti

Láminas comestibles edible leaves



401045
LÁMINAS ORO
Gold leaves
8 x 8 cm · 25 u.



401069
LÁMINAS ORO
Gold leaves
5 x 5 cm · 12 u.



401046
LÁMINAS
TRANSFER ORO
Gold transfer leaves
8 x 8 cm · 25 u.



401059
LÁMINAS PLATA
Silver leaves
8 x 8 cm · 25 u.



401067
TAPA DOSIFICADORA
Dosing cap



401068
BROCHA
Acrylic brush





Premium Set 401058

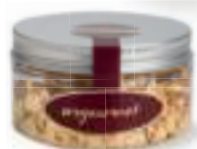

SHABIN
300 mg



POLVO *
POWDER
300 mg



COPOS *
FLAKES
300 mg



QUADRATUS *
300 mg



CORAZONES *
HEARTS
300 mg



PINZAS
TWEEZERS



* Compatible



TAPA
DOSIFICADORA
Dosing cap



FILAMENTOS *
FINOS
Thin gold filament
300 mg



FILAMENTOS *
GRUESOS
Thick gold filament
300 mg



BROCHA
ACRILIC BRUSH



LÁMINAS ORO
Gold leaves
8 x 8 cm · 25u.



LÁMINAS TRANSFER ORO
Gold transfer leaves
8 x 8 cm · 25u.



Colorantes

Colourings · Colorants

Colorantes · Coloranti



deKora

Special moments

COLORANTES

Colourings · Colorants · Colorantes · Coloranti

ROTULADORES PARA DECORAR

Decorating marking pens · Feutres pour décorer · Marca-textos para decorar
Pennarello per decorare



Modo de uso
How to use
Comment l'utiliser
Como utilizar
Come si usa



■ ROTULADOR ORO

Gold edible marker -
Marcador comestível dourado
- Marqueur or comestible.
Pennarello commestibile oro.

414108

x 12 x 1 u



■ 2 ROTULADORES NEGROS

2 black pastry pens
2 feutres noires
2 marca-textos pretos
2 pennarelli neri

414094

x 12 x 2 u



■ SURTIDO 4 ROTULADORES

Assortment 4 pastry pens.
Assorti 4 feutres.
Sortido 4 marca-textos.
Assortimento 4 pennarelli

414095

x 12 x 4 u



COLORANTES

Colourings · Colorants · Colorantes · Coloranti

EN PASTA

In paste · En pâte · Em pasta · In pasta





Modo de uso
How to use
Comment l'utiliser
Como utilizar
Come si usa



415057

Caja surtida - Assorted box
Boîte assortis - Caixa assortada
- Scatola assortimento

120 g · 30 g x 4 u  



415037

415046

415047

415049

415052



415053

415054

415055

415056



180 g · 30 g x 6 u



415037



415028

415040

415041

415042

415043

415044

415045

415048

415097

200 g · 1 u



415045

Dosis orientativa: 5 g x 10 Kg / Indicative dosis: 5 g x 10 Kg / Dose suggérée: 5 g x 10 Kg /
Dose indicada: 5 g x 10 Kg / Dose consigliata: 5 g x 10 Kg

COLORANTES

Colourings · Colorants · Colorantes · Coloranti

EN POLVO LIPOSOLUBLES

Liposoluble in powder · En poudre liposolubles · Em pó lipossolúveis
In polvere liposolubile

Modo de uso
How to use
Comment l'utiliser
Como utilizar
Come si usa



Colorante en polvo liposoluble ideal para la decoración de chocolate blanco, cremas, nata, pasta de azúcar, pasta para moldear, pasta de almendra, mazapán, manteca, semifrios o cualquier otro producto de base grasa.

Será aconsejable realizar una pre-mezcla del contenido a colorear para facilitar el uso y conseguir un color uniforme.

EN: Liposoluble powder colorant perfect for decorating white chocolate, custard, cream, sugar paste, moulding paste, almond paste, marzipan, butter, parfaits or any other fat-based product. You should prepare a pre-mix of the content

that is to be coloured to make it easier to use and attain a uniform colour. FR: Colorant en poudre liposoluble, idéal

pour décorer le chocolat blanc, les crèmes, crèmes dessert, la pâte à sucre, les pâtes à mouler, la pâte d'amande,

le massepain, le beurre, les parfait ou tout autre produit à base de matières grasses. IL est conseillé de faire un

pré-mélange du contenu à colorier pour faciliter l'utilisation et obtenir une couleur uniforme. PT: Corante em pó

lipossolúvel ideal para a decoração com chocolate branco, cremas, nata, pasta de açúcar, pasta para moldar, pasta

de amêndoa, maçapão, manteiga, semifrios ou qualquer outro produto de base gorda. É aconselhável realizar uma

pré-mistura do conteúdo a colorir para facilitar a utilização e conseguir uma cor uniforme. IT: Colorante in polvere

liposolubile, ideale per le decorazioni su cioccolata bianca, creme, panna, pasta di zucchero, pasta per fare stampi,

pasta di mandorle, marzapane, burro, semifreddi o qualsiasi altro prodotto con base grassa Sarà opportuno realizzare

una pre-miscela del contenuto da colorare, al fine di facilitarne l'utilizzo e ottenere un colore uniforme.

EFECTO PERLADO / | “Pearl effect” · Effet perlé · Efeito nacarado · Effetto perlati



Esta gama te permite conseguir efectos perlados y brillantes en masas, azúcar, frostings y chocolate.

EN: This range allows you to obtain shiny pearl effects on dough, sugar, frosting and chocolate. FR: Cette gamme vous

permet d'obtenir des effets nacrés et brillants en pâte, sucre, glaçage et chocolat. PT: Esta gama permite obter efeitos

perlados e brilhantes em massas, açúcar, coberturas glacé e chocolate. IT: Questa linea consente di ottenere effetti

perlati e brillanti, su impasti, zucchero, frosting e cioccolato.



418151
Oro

418021
Bronce

418152
Plata



COLORANTES

Colourings · Colorants · Colorantes · Coloranti

EN POLVO LIPOSOLUBLES

Liposoluble in powder · En poudre liposolubles · Em pó lipossolúveis
In polvere liposolubile

EFECTO MATE / Matte effect · Effet mat · Efeito mate · Effeto opaco

 25 g

Además, se trata de colorantes versátiles porque permite usarlos tanto para colorear superficialmente de forma directa, aplicándolos con un pincel o mezclándolos con una pequeña parte de alcohol.

EN: Furthermore, they are versatile colours because they can be used to colour straight onto the surface, applying them with a brush or mixing them with a small amount of alcohol.

FR: En plus, il s'agit de colorants polyvalents qui peuvent être utilisés aussi bien pour colorer rapidement une surface, en les appliquant au pinceau ou en les mélangeant avec une petite quantité d'alcool.

PT: Também é corantes versáteis porque pode-se utilizá-los para colorir superficialmente de forma direta, aplicando-os com um pincel ou misturando-os com uma pequena quantidade de álcool.

IT: Inoltre, si tratta di coloranti versatili perché possono essere utilizzati sia per colorare le superfici direttamente, applicandoli con un pennello o mescolando con una piccola parte di alcol.



418038
Rojo

418040
Verde

418039
Naranja

418036
Azul

418037
Amarillo

418130
Violeta

418034
Negro

418153
Rosa

418144
Rojo

418143
Amarillo

418154
Blanco

418175
Rojo Ferrari

COLORES NATURALES
Natural colors

COLORANTES

Colourings · Colorants · Colorantes · Coloranti

EN POLVO HIDROSOLUBLES

Water soluble powder · En poudre hydrosoluble dans l'eau
Em pó hidrossolúveis · In polvere idrosolubile



418135
Verde



418136
Azul



418138
Negro



418137
Naranja



418142
Blanco



418134
Amarillo



418133
Rojo



Modo de uso

How to use

Comment l'utiliser

Como utilizar

Come si usa



YouTube

Colorantes en polvo hidrosolubles ideales para colorear todo tipo de masas de productos a base de agua como pasta de azúcar, isomalt nata, merengue, macarons, bebidas y productos de panadería (bollería, galletas, tartas y gofres). Agregar el colorante directamente al producto. EN: Water-soluble powder ideal to mass colouring water-base products like sugar paste, isomalt, cream, meringue, macarons, cocktail, confectionery and fine bakery (pastries, cookies, cakes and wafers). Directly add the powder to the product to be colored. FR: Colorants en poudre solubles dans l'eau, parfaits pour colorer tout type de produits à base d'eau tels que la pâte à sucre, l'isomalt, la crème, la meringue, les macarons, les boissons et les produits de boulangerie (viennoiseries, biscuits, gâteaux et gaufres). Ajouter le colorant directement au produit. PT: Corantes em pó hidrossolúveis ideais para colorir todo o tipo de massas de produtos à base de água como, por exemplo, pasta de açúcar, isomalt nata, merengue, macarons, bebidas e produtos de padaria (bolos, bolachas, tartes e gofres). Adicionar o corante diretamente ao produto. IT: Colorante in polvere idrosolubile ideale per la colorazione in massa di prodotti a base acqua quali pasta di zucchero, isomalto zucchero, panna, meringhe, macarons, cocktails, prodotti di confetteria e da forno finiti (pasticcini, biscotti, torte e cialde). Aggiungere la polvere direttamente al prodotto da colorare.

25 g



COLORANTES

Colourings · Colorants · Colorantes · Coloranti

PULVERIZADOR

Sprinkler · Pulvérisateur · Spruzzatore

Colorante en polvo con dosificador para obtener efectos perlados y metalizados en elaboraciones de todo tipo, desde cremas, fondants, frostings, masas, chocolate, etc. Pulveriza directamente sobre la superficie del producto a colorear. EN: Powder colourant with a dispenser to obtain a pearlescent and metallic effect on all kinds of confectionery products, including creams, fondants, frostings, dough, chocolate, etc. Spray directly onto the surface of the product to be coloured. FR: Colorant en poudre avec doseur pour obtenir des effets perlés et métallisés dans des préparations de tout type, des crèmes, fondants, glaçages, pâtes, chocolat, etc. Vaporisez directement sur la surface du produit à colorer. PT: Corante em pó com doseador para obter efeitos perlados e metalizados em elaborações de todo tipo, desde cremes, fondants, coberturas de glacé, massas, chocolate, etc. Pulverize diretamente sobre a superfície do produto a colorir. IT: Colorante in polvere con dosatore per ottenere effetti perlati e metallizzati, in lavorazioni di qualsiasi tipo, dalle creme, fondant, frosting, impasti, cioccolato, ecc. Spolverare direttamente sulla superficie del prodotto da colorare.

EFECTO PERLADO

“Pearl effect” · Effet perlé · Efeito nacarado · Effetti perlati  10 g



418155
ORO - Gold
Or - Ouro



418070
ROJO - Red Rouge
Vermelho - Rosso



418174
PLATA - Silver
Argent - Prata
Argento



418159
VERDE ESMERALDA
Esmeralda green
Vert émeraude



418160
VIOLETA
Violet - Violette
Viola



418157
NEGRO - Black
Noir - Preto - Nero



418158
LILA - Lilac
Lila - Lilás



418156
ROSA - Pink
Rose - Rosa



COLORANTES

Colourings · Colorants · Colorantes · Coloranti

SPRAYS - BASE ALCOHOL

Alcohol based · Base d'alcool · Base de álcool · Base alcol

Colorantes alimentarios en spray, son ideales para colorear de forma sencilla productos tanto de azúcar como de chocolate. Para colorear bombones puede rociar directamente el interior del molde antes de rellenarlo con chocolate.

MODO DE USO: Agite bien el bote antes de usar y periódicamente durante la aplicación.

Antes de rociar sobre el postre, practique con una toalla de papel para familiarizarse con la aplicación del rociador. Rociar a una distancia de 25-30cm sosteniendo el bote lo más vertical posible. Limpiar la válvula con agua caliente con regularidad. Deje secar de 1 a 3 minutos. El rendimiento real variará dependiendo de la intensidad del color deseada.

EN: Food spray dyes ideal for easily colouring both sugar and chocolate products.

To colour chocolates you can directly spray the inside of the mould before filling it with chocolate.

HOW TO USE: Shake the bottle well before use and periodically during application. Before drizzling over dessert, practice on a paper towel to become familiar with applying the spray. Spray from a distance of 25-30cm, holding the can as vertical as possible. Clean the valve with hot water regularly. Let dry 1 to 3 minutes. Actual performance will vary depending on desired color intensity.

Resto de idiomas, consultar la web / Consulter les langues sur le site web / Consultar idiomas na web / Per le lingue disponibili consultare il sito web.

EFECTO AERÓGRAFO | Airbrush effect · Effet aérographe · Efeito aerógrafo · Effeto aerografo

 100 ml



430009



430074



430007



430082



430010



430006



430084



430086



COLORANTES

Colourings · Colorants · Colorantes · Coloranti

SPRAYS - BASE ALCOHOL

Alcohol based · Base d'alcool · Base de álcool
Base alcol



Modo de uso
How to use
Comment l'utiliser
Como utilizar
Come si usa

EFECTO PERLADO

“Pearl effect” · Effet perlé · Efeito nacarado · Effetto perlati

Agrega un acabado perlado a tus creaciones.

EN: Add a pearl finish to your creations. FR: Ajoutez une finition perlée à vos créations. PT: Adicione um acabamento perolado às suas criações. IT: Aggiungi una finitura perlata alle tue creazioni



 100 ml

430023



430104



430101



 400 ml

NEW

430106



 250 ml

430060



430102



430103



430089



COLORANTES

Colourings · Colorants · Colorantes · Coloranti

SPRAYS - BASE MANTECA DE CACAO

Cocoa butter base · Base beurre de cacao · Base manteiga de cacau
Base burro di cacao

Colorantes alimentarios a base de manteca de cacao coloreada especialmente diseñados para colorear semifríos, helados, mousses, etc.

EN: Food colourings based on coloured cocoa butter specially designed to colour semifreddos, ice creams, mousses, etc. FR: Colorants alimentaires à base de beurre de cacao coloré spécialement conçus pour colorer les plats semi-froids, les glaces, les mousses, etc. PT: Corantes alimentares à base de manteiga de cacau colorida especialmente concebidos para colorir semifrios, gelados, mousses, etc. IT: Coloranti alimentari a base di burro di cacao colorato, pensati specificamente per la colorazione di semifreddi, gelati, mousse ecc.



Modo de uso
How to use
Comment l'utiliser
Como utilizar
Come si usa

Aplicados sobre una superficie congelada, la manteca de cacao se cristaliza creando el efecto terciopelo.

MODO DE USO: El contenido del spray debe estar a una temperatura de entre 20 y 25 grados para que la manteca de cacao no esté solidificada. Si fuera necesario puede ser calentado al baño maría. Agitar enérgicamente para que los ingredientes se mezclen perfectamente. Rociar la pieza con el bote en posición vertical a una distancia de 20cm. Limpiar la boquilla con agua caliente tras su uso para evitar que queden restos y se obstruya.

EN: Applied to a **frozen** surface, cocoa butter crystallizes, creating the velvet effect. **DIRECTIONS FOR USE:** The content of the spray must be at a temperature between 20 and 25 degrees so that the cocoa butter is not solidified. If necessary it can be heated in a water bath. Shake vigorously so that the ingredients mix perfectly. Spray the piece with the can in a vertical position from a distance of 20cm. Clean the nozzle with hot water after use to prevent debris and clogging.

FR: Appliqué sur une surface **gelée**, le beurre de cacao cristallise, créant un effet velours. **CONSEILS D'UTILISATION:** Le contenu du spray doit être à une température comprise entre 20 et 25 degrés pour que le beurre de cacao ne se solidifie pas. Si nécessaire, il peut être chauffé au bain-marie. Agiter vigoureusement pour que les ingrédients se mélangent parfaitement. Vaporisez la pièce avec le bidon en position verticale à une distance de 20 cm. Nettoyez la buse avec de l'eau chaude après utilisation pour éviter les débris et le colmatage.

PT: Aplicada sobre uma superfície **congelada**, a manteiga de cacau cristaliza, criando o efeito aveludado. **INSTRUÇÕES DE USO:** O conteúdo do spray deve estar a uma temperatura entre 20 e 25 graus para que a manteiga de cacau não solidifique. Se necessário, pode ser aquecido em banho-maria. Agite vigorosamente para que os ingredientes se misturem perfeitamente. Pulverize a peça com a lata na posição vertical a uma distância de 20cm. Limpe o bico com água quente após o uso para evitar detritos e entupimentos.

IT: Applicato su una superficie **ghiacciata**, il burro di cacao cristallizza creando l'effetto velluto. **CONSIGLI D'USO:** Il contenuto dello spray deve essere ad una temperatura compresa tra 20 e 25 gradi in modo che il burro di cacao non si solidifichi. Se necessario può essere riscaldato a bagnomaria. Agitare vigorosamente in modo che gli ingredienti si amalgamino perfettamente. Spruzzare il pezzo con la bomboletta in posizione verticale da una distanza di 20cm. Pulire l'ugello con acqua calda dopo l'uso per evitare detriti e intasamenti.

EFECTO TERCIOPELO

Velvet effect · Effet velours · Efeito veludo · Effetto velluto



100 ml

430096



430098



400 ml

430076

Rojo cerezo



430091



430029



430092



430093



430095



430035

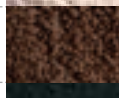

430099



430100



COLORANTES

Colourings · Colorants · Colorantes · Coloranti



COLORANTE SUPER CONCENTRADO

Super concentrated liquid liposoluble dye
Colorant super concentré liquide liposoluble
Corante líquido super concentrado lipossolúvel
Colorante super concentrato liquido liposolubile

30 ml · 1 u.

412067

412068

412069

412070

412071

412072

NEW 412075

NEW 412076

NEW 412077

Colorante super concentrado líquido liposoluble. No modifica ni el sabor ni la consistencia del producto a colorear. Puedes modular la intensidad del color en función de la cantidad de colorante fácilmente gracias a su tapón dosificador. Indicado para colorear masas con base grasa como chocolate, buttercream, masas para hornear, manteca de cacao, natas, etc. aSin E171,

sin gluten, sin alcohol. Apto para veganos y Kosher.

EN: Super concentrated liquid liposoluble dye. It does not alter the taste or consistency of the product being colored. You can easily adjust the color intensity based on the amount of dye thanks to its dosing cap. Suitable for coloring fat-based masses such as chocolate, buttercream, baking doughs, cocoa butter, creams, etc.

No E171, gluten-free, alcohol-free. Suitable for vegans and Kosher.

FR: Colorant super concentré liquide liposoluble. Il ne modifie ni le goût ni la consistance du produit à colorer. Vous pouvez facilement ajuster l'intensité de la couleur en fonction de la quantité de colorant grâce à son bouchon doseur. Convient pour colorer les pâtes à base de matières grasses telles que le chocolat, le beurre, les pâtes à pâtisserie, le beurre de cacao, les crèmes, etc. Sans E171, sans gluten, sans alcool. Adapté aux végétaliens et casher. PT: Corante líquido super concentrado lipossolúvel. Não altera o sabor nem a consistência do produto a ser colorido. Você pode ajustar facilmente a intensidade da cor com base na quantidade de corante graças à sua tampa dosadora. Indicado para colorir massas à base de gordura, como chocolate, buttercream, massas para assar, manteiga de cacau, natas, etc. Sem E171, sem glúten, sem álcool. Adequado para veganos e kosher.

IT: Colorante super concentrato liquido liposolubile. Non modifica né il sapore né la consistenza del prodotto da colorare. Puoi facilmente regolare l'intensità del colore in base alla quantità di colorante grazie al suo tappo dosatore. Indicato per colorare impasti a base di grassi come cioccolato, crema di burro, impasti per la cottura, burro di cacao, panna, ecc. Senza E171, senza glutine, senza alcoolAdatto per vegani e kosher.

IT: Colorante super concentrato liquido liposolubile. Non modifica né il sapore né la consistenza del prodotto da colorare. Puoi facilmente regolare l'intensità del colore in base alla quantità di colorante grazie al suo tappo dosatore. Indicato per colorare impasti a base di grassi come cioccolato, crema di burro, impasti per la cottura, burro di cacao, panna, ecc. Senza E171, senza glutine, senza alcoolAdatto per vegani e kosher.



YouTube



COLORANTES

Colourings · Colorants · Colorantes · Coloranti



COLORANTES

Colourings · Colorants · Colorantes · Coloranti

LÍQUIDOS LIPOSOLUBLES

Liposoluble liquids · Liquides liposolubles
Líquidos lipossolúveis · Liquidi liposolubili



Modo de uso
How to use
Comment l'utiliser
Como utilizar
Come si usa

Colorantes liposolubles con base de aceite y textura oleosa ideal para la decoración de chocolate, coberturas y otras masas grasas como cremas y manteca. Se recomienda agitar previamente para homogeneizar el producto y con la ayuda de su nuevo tapón dosificador podrá agregar progresivamente el colorante hasta conseguir la intensidad de color deseada.

EN: Liposoluble dye with oil base and oily texture ideal for decorating chocolate, coatings and other high in fat doughs such as creams and butters. It is recommended that you stir the product beforehand to blend it and with the helpful new dosing cap you can add the dye gradually until you reach the desired color intensity. FR: Colorant liposoluble à base d'huile et à texture huileuse, idéal pour décorer le chocolat, les enrobages et autres compositions grasses comme les crèmes et le beurre. Il est conseillé d'agiter le colorant au préalable pour homogénéiser le produit. Aidez-vous ensuite du nouveau bouchon doseur pour ajouter progressivement le colorant jusqu'à l'obtention de l'intensité de couleur souhaitée. PT: Corante lipossolúvel com base de óleo e textura oleosa ideal para a decoração com chocolate, coberturas e outras massas gordas como cremes e manteiga. Recomenda-se agitar previamente para homogeneizar o produto e ajudar-lhe com a sua nova tampa doseadora para adicionar progressivamente o corante até conseguir a intensidade de cor desejada. IT: Coloranti liposolubili a base di olio con consistenza oleosa, ideali per la decorazione del cioccolato, coperture e altri elementi grassi, come creme e burro. Si consiglia di agitare per omogeneizzare il prodotto. Servendosi del nuovo tappo con dosatore, è possibile aggiungere progressivamente il colorante fino a raggiungere l'intensità desiderata del colore.

EFECTO NEUTRO | Neutral effect · Effet neutre · Efeito neutro · Effeto neutro

 100 g



412024



412025



412026



412027



412066



COLORANTES

Colourings · Colorants · Colorantes · Coloranti



KIT AERÓGRAFO

Airbrush Kit · Kit
aérographe

539000

AERÓGRAFO

Airbrush - Aérographe - Aerógrafo

 1 u



El Kit incluye: aerógrafo doble acción de 0,2 mm, mini compresor de 1 bar, soporte para aerógrafo y bolsa de viaje.

EN: The Kit includes: dual action 0.2 mm airbrush, 1 bar mini compressor, airbrush holder and travel bag. FR: Le kit comprend : un aérographe à double action de 0,2 mm, un mini compresseur de 1 bar, un support pour aérographe et un sac de voyage. PT: O kit inclui: aerógrafo de dupla ação de 0,2 mm, mini compressor de 1 barra, suporte para aerógrafo e bolsa de viagem. IT: Il kit comprende: aerografo a doppia azione da 0,2 mm, mini compressore da 1 bar, supporto per l'aerografo e contenitore da viaggio.



COLORANTES

Colourings · Colorants · Colorantes · Coloranti

LÍQUIDOS ESPECIALES PARA AERÓGRAFO BASE AGUA

For airbrush water based · Pour aérographe base d'eau

Para aerógrafo base de água · Liquido speciale per aerografo base d'acqua



















Colorante líquido indicado para difuminar, marcar y pintar superficies de tartas y dulces con la ayuda de un aerógrafo. Gracias a su formulación hidrosoluble, también es ideal para la coloración de nata, cremas, gelatinas, pasta de almendra, mazapán, azúcar y bebidas en general.

EN: Liquid dye indicated to blend, set and paint cake and candy surfaces with the help of an airbrush. Thanks to its water-soluble composition, it is also ideal for coloring whipped cream, creams, jellies, almond paste, marzipan, sugar and drinks in general. FR: Colorant liquide parfait pour recouvrir, marquer et peindre les surfaces de gâteaux et autres desserts à l'aide d'un aérographe. Grâce à sa formulation hydrosoluble, ce colorant est également idéal pour la coloration des crèmes dessert, crèmes, gélatines, de la pâte d'amande, du massepain, du sucre et des boissons en général. PT: Corante líquido indicado para esfumar, marcar e pintar superfícies de bolos y doces com a ajuda de um aerógrafo. Graças à sua fórmula hidrossolúvel, também é ideal para a coloração de natas, cremes, gelatinas, pasta de amêndoa, maçapão, açúcar e bebidas em geral. IT: Colorante liquido indicato per sfumare, evidenziare e dipingere superfici di torte e dolci con l'aerografo Grazie alla sua formulazione idrosolubile, è anche ideale per la colorazione di panna, creme, gelatine, pasta di mandorle, marzapane, zucchero e bevande in generale.

EFFETTO NEUTRO | Neutral effect · Effet neutre
Efeito neutro · Effeto neutro

190 ml · 1 u 



412012		
412014		
412015		
412016		 
412017		
412018		
412019		
412020		
412021		



COLORANTES

Colourings · Colorants · Colorantes · Coloranti

CONSUMIBLES PARA IMPRESORAS

Consumables for printers · Consommables pour des imprimantes
Consumíveis para impressoras · Idonei all'uso con stampante

PASO A PASO

Step by step - Pas à pas - Passo a passo - Passo dopo passo



1 - Retirar las protecciones color naranja del cartucho.
EN: Take the orange protectors off the cartridge. FR: Retirer les protections couleur orange de la cartouche. PT: Retirar as proteções cor de laranja dos tinteiros. IT: Rimuovere le protezioni arancioni dalla cartuccia



2 - Sujetar el cartucho por los extremos sin apretar el tanque de tinta, de lo contrario la tinta saldrá por el orificio.
EN: Hold the cartridges at each end without squeezing the ink can, if not then the ink will leak out of the hole. FR: Fixer la cartouche par les extrémités sans serrer la réservoir d'encre, sinon l'encre sortira par l'orifice. PT: Segurar o tinteiro nos extremos sem apertar o tanque de tinta, caso contrario a tinta sai pelo orifício. IT: Afferrare la cartuccia dalle estremità senza esercitare pressioni sul serbatoio dell'inchiostro o questo uscirà dall'orifizio



3 - Retirar la tapa de silicona.
EN: Take off the silicon lid. FR: Retirer le couvercle en silicone. PT: Retirar a tampa de silicone. IT: Rimuovere il tappo in silicone.



4 - Colocar el cartucho en la impresora.
EN: Place the cartridge in the printer. FR: Placer la cartouche dans l'imprimante. PT: Colocar o tinteiro na impressora. IT: Collocare la cartuccia nella stampante.



5 - Al colocar el cartucho en la impresora, se debe encender un led de color rojo, si no se enciende es que hay algún error. POSIBLES CAUSAS: Chip quemado, cartucho intercambiado, contactos de chip obstruidos, etc.
EN: When the cartridge is placed in the printer, a red LED should light up. If this is not the case, then there is an error. POSSIBLE CAUSES: Burnt chip, switched cartridge, chip contact obstructed, etc. FR: En plaçant la cartouche dans l'imprimante, il faut allumer une led de couleur rouge. Si elle ne s'allume pas, cela signifie qu'il y a une erreur. CAUSES POSSIBLES : puce brûlée, cartouche échangée, contacts de puce obstrués, etc. PT: Ao colocar o tinteiro na impressora, tem de acender um led de cor vermelha, caso não acenda, ou caso fique a piscar algo de errado aconteceu! POSSIVEIS CAUSAS: Chip queimado, tinteiro trocado, contactos de chip obstruídos, etc. IT: Dopo aver collocato la cartuccia nella stampante, si noterà che si accenderà una luce led rossa; se non avviene, allora si è verificato un errore. CAUSE POSSIBILI: chip bruciato, cartuccia invertita, contatti del chip ostruiti, ecc.

COLORANTES

Colourings · Colorants · Colorantes · Coloranti



412023

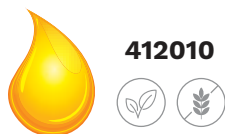

412010

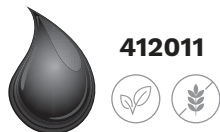

412011

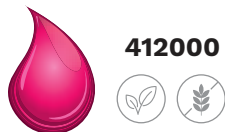

412000



Compatible con las impresoras.
EN: Compatible with printers.
FR: Compatible avec les imprimantes
PT: Compatível com as impressoras
IT: Compatibile con le stampanti:
EcoTank ET-14000; EcoTank ET-2500;
EcoTank ET-2550; EcoTank ET-2600;
EcoTank ET-2650; EcoTank ET-4500;
EcoTank L355; EcoTank L555

 1 u.

■ BOTE COLORANTE PARA IMPRESORAS EPSON (80 c.c.)

Colour box for Epson printers (80 c.c.) - Boîte colorant pour imprimante Epson (80 c.c.) - Pote colorante para impressora Epson (80 c.c.) - Barattolo colorante per stampanti Epson (80 c.c.)



627051

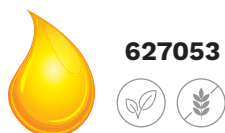

627053

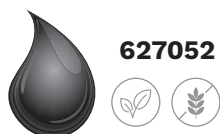

627052

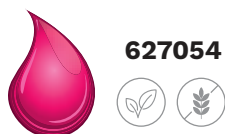

627054



Compatible con las impresoras.
EN: Compatible with printers.
FR: Compatible avec les imprimantes
PT: Compatível com as impressoras
IT: Compatibile con le stampanti:
EcoTank ET4750/3750/3700/
2756/2751/2700/15000/4700/
2726/2720/2715/2714/2712/
2711/2710.

 1 u.

■ BOTE COLORANTE PARA IMPRESORAS EPSON (100 c.c.)

Colour box for Epson printers (100 c.c.) - Boîte colorant pour imprimante Epson (100 c.c.) Pote colorante para impressora Epson (100 c.c.) - Barattolo colorante per stampanti Epson (100 c.c.)



627027

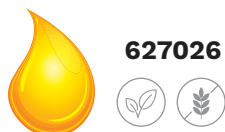

627026



627028

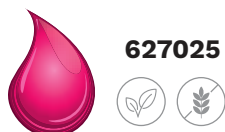

627025



 1 u.

■ BOTE COLORANTE PARA IMPRESORAS CANON (60 c.c.)

Colour box for Canon printers (60 c.c.) - Boîte colorant pour imprimante Canon (60 c.c.) Pote colorante para impressora Canon (60 c.c.) - Barattolo colorante per stampanti Canon (60 c.c.)

COLORANTES

Colourings · Colorants · Colorantes · Coloranti



1 u.

■ CARTUCHOS APTOS PARA LAS NUEVAS IMPRESORAS CANON CON MICROCHIP (PGI-550/CLI-551)

Edible ink cartridges for the new Canon printers with microchip - Des cartouches aptes pour les nouvelles imprimantes Canon avec microchip - Cartuchos aptos para as novas impressoras Canon com microchip - Cartucce idonee all'utilizzo con le nuove stampanti canon con microchip.



627010



627041



627006



627007



627018



627042



1 u.

■ CARTUCHOS APTOS PARA LAS NUEVAS IMPRESORAS CANON CON MICROCHIP (PGI-570/CLI-571)

Edible ink cartridges for the new Canon printers with microchip. - Des cartouches aptes pour les nouvelles imprimantes Canon avec microchip. - Cartuchos aptos para as novas impressoras Canon com microchip. - Cartucce idonee all'utilizzo con le nuove stampanti canon con microchip.

(*) MAS GRANDE/ bigger/ plus gros/ Maior / Più grandi



413003



413001



413000



413004



413002



COLORANTES

Colourings · Colorants · Colorantes · Coloranti

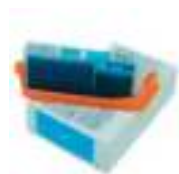

627047



627048



627049



627050



627046



1 u.

■ CARTUCHOS APTOS PARA LAS NUEVAS IMPRESORAS CANON CON MICROCHIP (PGI580 e CLI581)

(Canon pixma tr7550, Canon pixma tr8550, Canon pixma ts705, Canon pixma ts6150, Canon pixma ts6151, Canon pixma ts6250, Canon pixma ts6251, Canon pixma ts6350, Canon pixma ts8150, Canon pixma ts8151, Canon pixma ts8152, Canon pixma ts9150, Canon pixma ts9155)

Edible ink cartridges for the new Canon printers with microchip. - Des cartouches aptes pour les nouvelles imprimantes Canon avec microchip. - Cartuchos aptos para as novas impressoras Canon com microchip. - Cartucce idonee all'utilizzo con le nuove stampanti canon con microchip.

(*) MAS GRANDE/ bigger/ plus gros/ Maior / Più grandi



413006



413009



413007



413008



1 u.

■ CARTUCHOS APTOS PARA IMPRESORAS EPSON 16 Series

(WF-2540WF, WF-2520NF, WF-2510WF, WF-2010W)

Edible ink cartridges for Epson printers with microchip - Des cartouches aptes pour imprimantes Epson Cartuchos aptos para as impressoras Epson - Cartucce adatte per stampanti Epson.

TUTORIAL CARTUCHOS TINTA ALIMENTARIA

Food dye containers - Cartouches d'encre alimentaire - Cartuchos de tinta comestível - Tutorial cartucce inchiostro alimentare

Escanea este código QR y sigue los sencillos pasos de este vídeo.

EN: Scan this QR code and follow the simple steps in this video. FR: Scannez ce code QR et suivez les étapes de cette vidéo. PT: Digitalize este código QR e siga os passos simples deste vídeo. IT: Scannerizza questo codice QR e segui le semplici istruzioni fornite nel video.



LÁMINA COMESTIBLE PARA IMPRIMIR

Edible printer sheets · Feuilles comestibles pour impression
Folhas comestíveis para imprimir · Lamina commestibile per la stampa

FABRICADO EN EUROPA. Elaborado bajo estrictos controles de calidad.
MADE IN EUROPE Produced under strict quality controls.
FABRIQUÉ EN EUROPE. Fabriqué sous de stricts contrôles de qualité.
FABRICADO NA EUROPA Preparado sob rigorosos controlos de qualidade.
PRODOTTO IN EUROPA Prodotto osservando i più rigorosi standard di qualità.



* SIN AZÚCAR Gracias a su composición es apto para clientes que buscan reducir o controlar el consumo de azúcar.
EN: SUGAR FREE Thanks to its composition, it is suitable for customers looking to reduce or control their sugar intake.
FR: SANS SUCRE Grâce à sa composition, il convient aux clients qui cherchent à réduire ou à contrôler leur consommation de sucre.
PT: SEM AÇÚCAR Devido à sua composição é apropriado para clientes que pretendem reduzir ou controlar o consumo de açúcar.
IT: SENZA ZUCCHERO Grazie alla sua speciale composizione, risulta idoneo per clienti che mirano a ridurre o controllare il consumo di zuccheri.

LÁMINA COMESTIBLE

EN: Edible printer sheets. FR: Feuilles comestibles pour impression. PT: Folhas comestíveis para imprimir IT: Lamina commestibile

421005	* ZERO A3 29,7 x 42 cm	20 u.						
421004	* ZERO A4 21 x 29,7 cm	25 u.						
421010	A4 21 x 29,7 cm	25 u.						



OBLEA PARA IMPRIMIR

Wafer ready to print · Azyme pour imprimer
Obreia para imprimir · Oblea per la stampa

107127

DOBLE CARA LISA

Double smooth face - Double face lisse.

29,7 x 42 cm **DIN A3** ·  50 u



107117

DOBLE CARA LISA

Double smooth face - Double face lisse.

21 x 29,7 cm **DIN A4** ·  50 u

650 g aprox. · 0,65 mm aprox.



107031

UNA CARA LISA PARA MÁQUINAS DE ÚLTIMA GENERACIÓN.

One smooth face for new generation printers. - Une face lisse. -

Un lato liscio per le macchine di ultima generazione

21 x 29,7 cm **DIN A4** ·  50 u

270 g aprox. · 0,27 mm aprox.

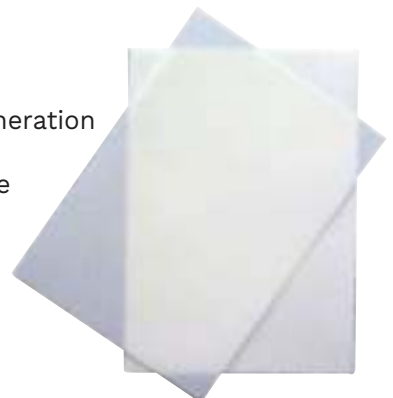

OBLEA INDUSTRIAL

Industrial wafer · Azyme industrielle Obreia industrial · Oblea industriale



107033

Ø 20 cm

150 u.



107020

50 x 40 cm · 2 kg.



107022

70 x 40 cm · 3 kg.



OBLEA INDUSTRIAL: 1 CARA LISA/ 1 CARA RAYADA

Industrial wafer: 1 Face lined/ 1 face smooth. • Azyme industrielle: 1 Face lisse/1 face rayée.

Obreia industrial: 1 Cara lisa/ 1 cara rayada. • Oblea industriale: 1 lato liscio / 1 faccia rigata.

LÁMINA SERIGRAFÍA PARA IMPRESIÓN EN CHOCOLATE

Transfer sheet for chocolate printing · Lame serigraphie impression en chocolat · Lâmina serigrafia para impressão em chocolate · Lamina da serigrafia per la stampa sul cioccolato



545083

21 x 29,7 cm **DIN A4**

30 u.



COLORANTES

Colourings · Colorants · Colorantes · Coloranti



Resto de idiomas
Other languages
Autres langues
Outros idiomas
Altre lingue



CARTUCHOS Y BOTES DE TINTA ALIMENTARIA

CONSEJOS Y RECOMENDACIONES

Food ink cartridges and containers. Tips and recommendations
Cartouches et récipients d'encre alimentaire. Conseils et recommandations
Cartuchos e recipientes de tinta alimentícia. Dicas e recomendações
Cartucce e contenitori di inchiostro alimentare. Consigli e raccomandazioni

En el mercado hay de dos tipos de impresoras, EPSON y CANON:

EPSON

Trabajan mediante un sistema de impresión que impulsa la gota de tinta desde la boquilla al papel a través de una presión.

Work by a printing system that propels ink droplets from the nozzle to the paper through pressure.

Canon

Tienen un proceso de inyección térmico.

A pesar de su buena calidad de impresión, las tintas CANON pueden sufrir cambios debido a ese calentamiento que necesitan para su funcionamiento. Por otro lado, las tintas EPSON por lo general garantizan una mayor rapidez y estabilidad con las tintas y tienen una buena calidad de impresión.



Nuestra recomendación es usar impresoras EPSON con nuestros cartuchos y/o botes de tinta alimentaria compatibles.

IMPRESORAS Y TINTAS COMPATIBLES

Compatible printers and inks - Imprimantes et encres compatibles - Impresoras e tintas compatíveis
Stampanti e inchiostri compatibili

En estas páginas podrá buscar y comprobar qué impresoras o qué cartuchos y tintas son compatibles:

EN: On these pages, you can search and check which printers or which cartridges and inks are compatible: FR: Sur ces pages, vous pouvez rechercher et vérifier quelles imprimantes ou quelles cartouches et encres sont compatibles. compatibles: PT: Nestas páginas, você pode procurar e verificar quais impressoras ou quais cartuchos e tintas são compatíveis: IT: Su queste pagine, è possibile cercare e verificare quali stampanti o quali cartucce e inchiostri sono compatibili:

Canon



EPSON



Decoración no comestible

Non edible decoration

Décoration non comestible

Decoração não comestível

Decorazione non commestibile



deKora

Special moments

DECORACIÓN NO COMESTIBLE

Non edible decoration · Décoration non comestible · Decoração não comestível · Decorazione non commestibile

PVC · PLASTIC FIGURINES



302012
MINNIE
8,5 cm ·  x 6 





302029
PEPPA PIG
11 cm ·  x 4 



Front - Anverso

Back - Reverso



303020
FROZEN
9,5 cm ·  x 6 



DECORACIÓN NO COMESTIBLE

Non edible decoration · Décoration non comestible · Decoração não comestível · Decorazione non commestibile

PVC · PLASTIC FIGURINES



302044
PAW PATROL
6 cm ·  x 6 

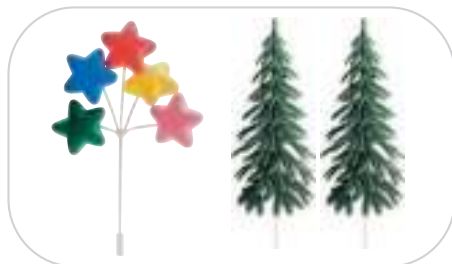

Disney Junior
MICKEY

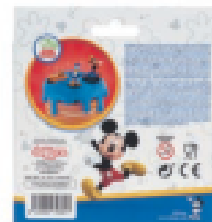

350181
MICKEY AND FRIENDS
3 - 3,5 cm ·  6 u.





DECORACIÓN NO COMESTIBLE

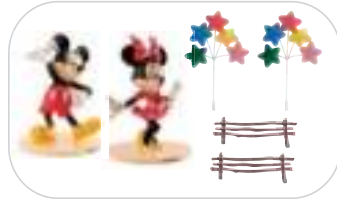

Non edible decoration · Décoration non comestible · Decoração não comestível · Decorazione non commestibile

PVC · PLASTIC FIGURINES



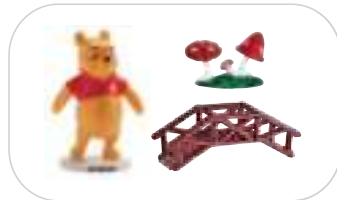

350057
MICKEY & MINNIE
9 cm ·  x 6 

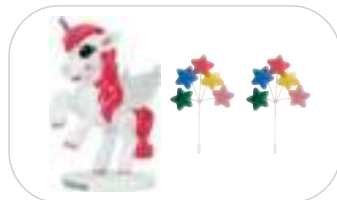

350233
WINNIE THE POOH
8,5 cm ·  x 6 



303018
UNICORNIO / UNICORN
8,5 cm ·  x 6 



DECORACIÓN NO COMESTIBLE



Non edible decoration · Décoration non comestible · Decoração não comestível · Decorazione non commestibile

PVC · PLASTIC FIGURINES



(x 10 u.)

(x 10 u.)

303023
KIT PVC MICKEY
CON VELAS
9 cm ·  x 6 

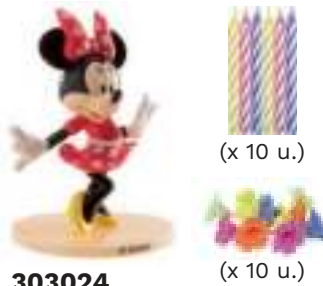

(x 10 u.)

(x 10 u.)

303024
KIT PVC MINNIE
CON VELAS
9 cm ·  x 6 



(x 10 u.)

(x 10 u.)

303028
KIT PVC TESIA
CON VELAS
8,5 cm ·  x 6 



DECORACIÓN NO COMESTIBLE

Non edible decoration · Décoration non comestible · Decoração não comestível · Decorazione non commestibile

PVC · PLASTIC FIGURINES



(x 10 u.)

(x 10 u.)

303027

KIT PVC PAW PATROL
CON VELAS

6 cm ·  x 6 



NEW

303033

KIT PVC CARS
CON VELAS

8 cm ·  x 6 

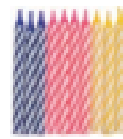

(x 10 u.)



(x 10 u.)

DECORACIÓN NO COMESTIBLE

Non edible decoration · Décoration non comestible · Decoração não comestível · Decorazione non commestibile

PVC · PLASTIC FIGURINES



NEW

303036
KIT PVC CIRCO
CON VELAS
26,5 cm ·  x 6 



(x 10 u.)



(x 10 u.)



NEW

303035
KIT PVC PIRATAS
CON VELAS
11 X 11 cm ·  x 6 

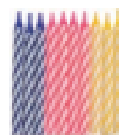

(x 10 u.)



(x 10 u.)

DECORACIÓN NO COMESTIBLE

Non edible decoration · Décoration non comestible · Decoração não comestível · Decorazione non commestibile

PVC · PLASTIC FIGURINES



(x 10 u.)



(x 10 u.)

303025
KIT PVC FROZEN
CON VELAS

9,5 cm ·  x 6 

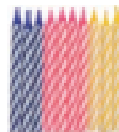

(x 10 u.)



(x 10 u.)

NEW **303037**
KIT PVC FROZEN
ANNA CON VELAS

9,5 cm ·  x 6 



(x 10 u.)



(x 10 u.)

NEW **303030**
KIT PVC ARIEL

8,5 cm ·  x 6 



DECORACIÓN NO COMESTIBLE

Non edible decoration · Décoration non comestible · Decoração não comestível · Decorazione non commestibile

PVC · PLASTIC FIGURINES



(x 10 u.)



(x 10 u.)

303026
KIT PVC SPIDERMAN
CON VELAS

9 cm ·  x 6 

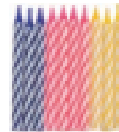

(x 10 u.)



(x 10 u.)

NEW

303034
KIT PVC CAPITÁN AMÉRICA
CON VELAS

7,5 cm ·  x 6 



DECORACIÓN NO COMESTIBLE

Non edible decoration · Décoration non comestible · Decoração não comestível · Decorazione non commestibile

PVC · PLASTIC FIGURINES

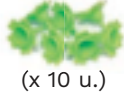
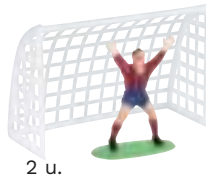

303029
KIT PVC FÚTBOL
CON VELAS
8,5 cm · x 6



NEW

303041
KIT PVC FÚTBOL
8,5 cm · x 6

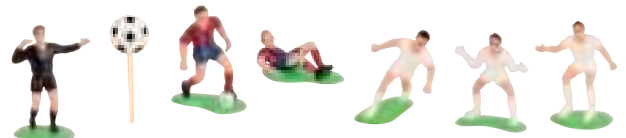
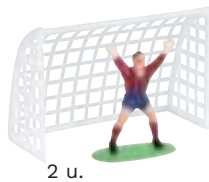

302018
KIT PVC FÚTBOL
8,5 cm · x 6



DECORACIÓN NO COMESTIBLE

Non edible decoration · Décoration non comestible · Decoração não comestível · Decorazione non commestibile

PVC · PLASTIC FIGURINES



302057

BALONES FÚTBOL

Ø 2,3 cm ·  x 12  x 6 u.



350186

5 - 6,5 cm ·  x 12 kits



DECORACIÓN NO COMESTIBLE

Non edible decoration · Décoration non comestible · Decoração não comestível · Decorazione non commestibile

PVC · PLASTIC FIGURINES



PEANUTS®

350071

5 cm ·  x 6 kits



nickelodeon.

Bob ESPONJA™



350019

5 - 5,5 cm ·  x 10 kits



DECORACIÓN NO COMESTIBLE

Non edible decoration · Décoration non comestible · Decoração não comestível · Decorazione non commestibile

PVC · PLASTIC FIGURINES



350196

6 cm ·  x 6 kits

11 x H: 12 cm

2 u.



347157

CARS

8 cm

 6 u.



Disney
**Winnie
the Pooh**

347182

WINNIE THE
POOH

8,5 cm ·  6 u.



DECORACIÓN NO COMESTIBLE

Non edible decoration · Décoration non comestible · Decoração não comestível · Decorazione non commestibile

PVC · PLASTIC FIGURINES



347145
BRANCH - TROLLS
7 cm ·  6 u.



347094
BOB ESPONJA
8 cm ·  12 u.



347160
SHINE
8 cm ·  6 u.



PEANUTS

347133
PEANUTS
5 cm ·  x 5 u



PEANUTS

347134
PEANUTS
5 cm ·  x 5 u



DECORACIÓN NO COMESTIBLE

Non edible decoration · Décoration non comestible · Decoração não comestível · Decorazione non commestibile

PVC · PLASTIC FIGURINES



347173
MICKEY
9 cm
6 u.



347174
MINNIE
9 cm
6 u.



347150
PLUTO
7 cm
6 u.



347149
DAISY
8,5 cm · 6 u.



347121
PEPPA PIG
11 cm · 6 u.



347168
UNICORNIO
UNICORN
8,5 cm · 6 u.



347131
PAW PATROL
6 cm · 12 u.



DECORACIÓN NO COMESTIBLE

Non edible decoration · Décoration non comestible · Decoração não comestível · Decorazione non commestibile

PVC · PLASTIC FIGURINES



347170
ELSA
9,5 cm ·  6 u.



347171
ANNA
9,5 cm ·  6 u.



Disney
PRINCESS

347155
ARIEL
8,5 cm ·  6 u.



347107
BELLA
8,5 cm ·  6 u.



347108
CENICIENTA
8,5 cm ·  6 u.



DECORACIÓN NO COMESTIBLE

Non edible decoration · Décoration non comestible · Decoração não comestível · Decorazione non commestibile

PVC · PLASTIC FIGURINES

MARVEL
SPIDER-MAN



© MARVEL

MARVEL
AVENGERS

347152
CAPITÁN AMÉRICA
7,5 cm ·  6 u.



© MARVEL

347153
IRON MAN
7,5 cm ·  6 u.



© MARVEL

347158
SPIDER-MAN
9 cm ·  6 u.



nickelodeon
TURTLES

347120
TORTUGAS NINJA
8 cm ·  12 u.



DECORACIÓN NO COMESTIBLE

Non edible decoration · Décoration non comestible · Decoração não comestível · Decorazione non commestibile



347141
JETT

9 cm · 6 u.



347142
JEROME

9 cm · 6 u.



347143
DIZZY

9 cm · 6 u.



MINIONS

349006
STUART_MINIONS

6 cm · 10 u.

Porcelana · Porcelain
Porcelaine · Porcellana



MINIONS

349000
KEVIN_MINIONS

7 cm · 10 u.

Porcelana · Porcelain
Porcelaine · Porcellana



Trolls

349009
BRANCH_TROLLS

7 cm · 10 u.

Porcelana · Porcelain
Porcelaine · Porcellana



Trolls

349030
POPPY_TROLLS

7 cm · 10 u.

Porcelana · Porcelain
Porcelaine · Porcellana



350132

11 x 4 x H: 3,5 cm · 30 u.



350134

13 x 3 cm · 144 u.



350238

4 x 4 cm · 50 u.



350251

4 x 4 cm · 50 u.



DECORACIÓN NO COMESTIBLE

Non edible decoration · Décoration non comestible · Decoração não comestível · Decorazione non commestibile

PVC · PLASTIC FIGURINES

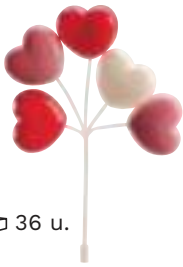

350022

17 cm · 36 u.



350023

17 cm · 36 u.



350229

17 cm · 36 u.



350145

17 cm · 36 u.



350027

17 cm · 144 u.



350030

12 cm · 36 u.



350235

8,5 cm · 144 u.



350039

Ø 2,3 cm · 144 u.



350230

26,5 cm · 24 u.



350059

12,5 x 7 x 5 cm · 24 u.



350231

11 x 11 cm · 36 u.



350236

5,5 cm · 144 u.



350207

Ø 8 x 7 cm · 12 u.



DECORACIÓN NO COMESTIBLE

Non edible decoration · Décoration non comestible · Decoração não comestível · Decorazione non commestibile

PVC · PLASTIC FIGURINES



350208

7,5 cm · 144 u.



301029

11 cm

x 12 x 12 u.



x 4 x 4 x 4



350129

11,5 cm · 144 u.



350136

2 cm · 144 u.



350135

4 x 5 cm · 144 u.



350131

8,5 / 9 cm.

144 u.



354146

9 / 9,5 cm.

72 u.



354145

5 cm · x 72 u.



350209

5 x 5 cm · x 144 u.



354144

5 cm.

72 u.



354074

4 cm.

144 u.



DECORACIÓN NO COMESTIBLE

Non edible decoration · Décoration non comestible · Decoração não comestível · Decorazione non commestibile

COIN BANKS · TIRELIRES · MEALHEIROS · SALVADANAÍ



MARVEL
SPIDER-MAN

204011

Spider-Man con oblea/
with wafer / avec azyme /
com obreia / con cialda
10 g ·  6 u.



204012

Cars con oblea/
with wafer / avec azyme /
com obreia / con cialda
10 g ·  6 u.



DECORACIÓN NO COMESTIBLE

Non edible decoration · Décoration non comestible · Decoração não comestível
Decorazione non commestibile

COIN BANKS · TIRELIRES · MEALHEIROS · SALVADANAÍ

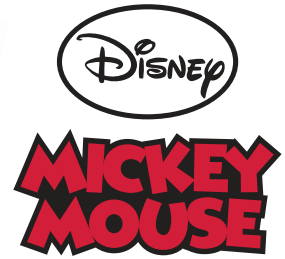

204009

Mickey Mouse con oblea/
with wafer / avec azyme /
com obreia / con cialda
10 g · 6 u.



DECORACIÓN NO COMESTIBLE

Non edible decoration · Décoration non comestible · Decoração não comestível
Decorazione non commestibile

COIN BANKS · TIRELIRES · MEALHEIROS · SALVADANAÍ



x4

Peppa PigTM

204001

Peppa Pig con piruletas /
with lollipops / avec
sucettes / com pirulitos /
con lecca-lecca
28 g ·  6 u.



18 cm

13 cm

9,3 cm

204018

Unicornio con caramelos
with candies / avec
bonbons / com doces /
con caramelle
30 g ·  4 u.



DECORACIÓN NO COMESTIBLE

Non edible decoration · Décoration non comestible · Decoração não comestível · Decorazione non commestibile

Cubre tu tarta y sopla las velas de forma segura e higiénica

Cover your cake and blow out the candles safely and hygienically



354124

MICKEY AND FRIENDS

Ø 25 cm · H: 12 cm ·  x 1 u.



354134

AVENGERS

Ø 25 cm · H: 12 cm ·  x 1 u.



Cubre-Tartas
Cake-Cover

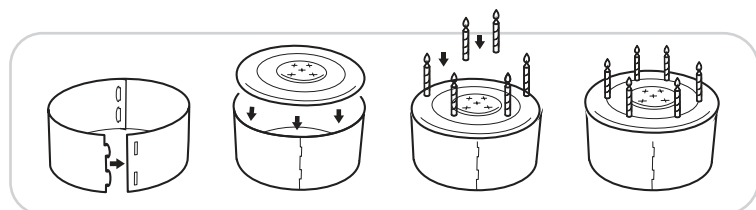

Velas no incluidas - Candles not included

DECORACIÓN NO COMESTIBLE

Non edible decoration · Décoration non comestible · Decoração não comestível
Decorazione non commestibile

CUPCAKE CAPSULES · CAISSETES CUPCAKES · CÁPSULAS CUPCAKES · CAPSULE DI CUPCAKE



339264
MINNIE



339260
PEPPA PIG



339240
CINDERELLA



339262
FROZEN II



339263
MICKEY



339267
CARS



339257
PJ MASKS



339258
PAW PATROL



339255
FAST FOOD



339265
FOOTBALL



339237
LOONEY TUNES



339261
SPIDER-MAN



All our range of Cupcake Capsules is suitable for food contact. - Toda nuestra selección de Cápsulas Cupcakes + Kits es apta para el contacto alimentario. - Toute notre sélection de Caissettes Cupcakes est adaptée au contact alimentaire. - A nossa seleção de Capsulas Cupcakes é adequada para contato alimentar. - La nostra selezione di capsule cupcake + kit è idonea al contatto con alimenti.

DECORACIÓN NO COMESTIBLE

Non edible decoration · Décoration non comestible · Decoração não comestível · Decorazione non commestibile

CUPCAKE CAPSULES · CAISSETES CUPCAKES · CÁPSULAS CUPCAKES · CAPSULE DI CUPCAKE



339264

MINNIE

Ø 5 x H: 3 cm.

☞ x 8 ☞ x 25 u.



339260

PEPPA PIG

Ø 5 x H: 3 cm.

☞ x 8 ☞ x 25 u.



339240

CINDERELLA

Ø 5 x H: 3 cm.

☞ x 8 ☞ x 50 u.



339262

FROZEN II

Ø 5 x H: 3 cm.

☞ x 8 ☞ x 25 u.



DECORACIÓN NO COMESTIBLE

Non edible decoration · Décoration non comestible · Decoração não comestível · Decorazione non commestibile

CUPCAKE CAPSULES · CAISSETES CUPCAKES · CÁPSULAS CUPCAKES · CAPSULE DI CUPCAKE



339263
MICKEY

Ø 5 x H: 3 cm.
📦 x 8 📄 x 25 u.



339267
CARS

Ø 5 x H: 3 cm.
📦 x 8 📄 x 25 u.



339257
PJ MASKS

Ø 5 x H: 3 cm.
📦 x 8 📄 x 25 u.



339258
PAW PATROL

Ø 5 x H: 3 cm.
📦 x 8 📄 x 25 u.



DECORACIÓN NO COMESTIBLE

Non edible decoration · Décoration non comestible · Decoração não comestível · Decorazione non commestibile

CUPCAKE CAPSULES · CAISSETES CUPCAKES · CÁPULAS CUPCAKES · CAPSULE DI CUPCAKE



339255

FAST FOOD

Ø 5 x H: 3 cm.

☞ x 8 ☞ x 25 u.



339265

FOOTBALL

Ø 5 x H: 3 cm.

☞ x 8 ☞ x 25 u.



DECORACIÓN NO COMESTIBLE

Non edible decoration · Décoration non comestible · Decoração não comestível · Decorazione non commestibile

CUPCAKE CAPSULES · CAISSETES CUPCAKES · CÁPSULAS CUPCAKES · CAPSULE DI CUPCAKE



339237
LOONEY TUNES

Ø 5 x H: 3 cm.

☞ x 8 ☞ x 50 u.



339261
SPIDER-MAN

Ø 5 x H: 3 cm.

☞ x 8 ☞ x 25 u.



DECORACIÓN NO COMESTIBLE

Non edible decoration · Décoration non comestible · Decoração não comestível
Decorazione non commestibile

CUPCAKE CAPSULES + KITS · CAISSETES CUPCAKES + KITS
CÁPSULAS CUPCAKES + KITS · CAPSULE DI CUPCAKE + KITS



Tesia & friends

339252
TESIA

x 6



6,5 cm



x 12 u.

5,5 cm

6,5 cm



x 12 u.

5,5 cm



x 12 u.



x 12 u.

Disney
MICKEY
AND FRIENDS

339269
MICKEY AND FRIENDS

x 6



5 cm



x 12 u.

4 cm

6 cm



x 12 u.

5 cm

11,5 cm

7 cm



14,3 cm



x 24 u.

Cake toppers



deKora

Special moments



YouTube

CAKE TOPPERS

PLÁSTICO · PLASTIC · PLASTIQUE · PLÁSTICO · PLASTICA

Felicidades Parabens



354154
11 x 14 cm
📄 x 6 📄

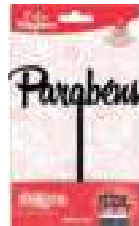

NEW

354173
11 x 14 cm
📄 x 6 📄



Parabens



354157
11 x 14 cm
📄 x 6 📄



Happy Birthday



354136
18 x 10 cm · 📄 x 6 📄



Happy Birthday



354112
*Oro efecto espejo
Gold mirror effect
15,4 x 10 cm · 📄 x 6 📄



Byon's Compeanito



354166
*Oro efecto espejo
Gold mirror effect
15,4 x 10 cm · 📄 x 6 📄



Joyeux Anniversaire



NEW

354171
14 x 10 cm · 📄 x 6 📄



Joyeux Anniversaire



354158
10 x 16 cm
📄 x 6 📄



CAKE TOPPERS

PLASTICO · PLASTIC · PLASTIQUE · PLÁSTICO · PLASTICA



354162
10 x 15,6 cm
📄 x 6 📄



NEW

354175
15 x 10 cm
📄 x 6 📄



354161
10 x 14,3 cm
📄 x 6 📄



NEW

354174
16 x 11 cm
📄 x 6 📄



354119
16 x 6 cm
📄 x 6 📄



354151
17 x 10 cm
📄 x 6 📄

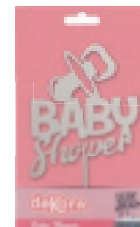

354108
*Plata efecto espejo
Silver mirror effect
16 x 10 cm · 📄 x 6 📄



CAKE TOPPERS

PLÁSTICO · PLASTIC · PLASTIQUE · PLÁSTICO · PLASTICA



354156
12 x 15 cm
x 6



354113
13,5 x 10 cm
x 6



354114
13,2 x 11,3 cm · x 6



NEW

354177
1,6,5 x 10,5 cm
x 6

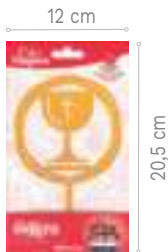
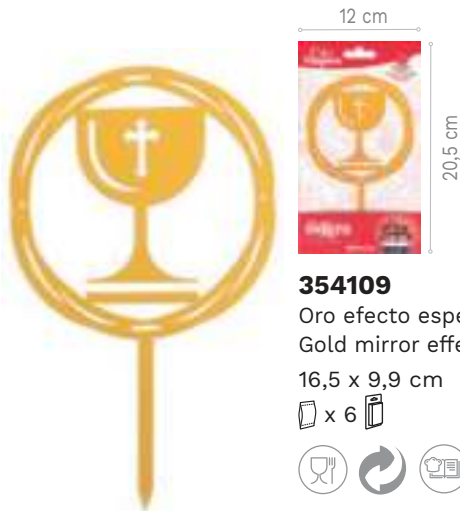

354109
Oro efecto espejo
Gold mirror effect
16,5 x 9,9 cm
x 6

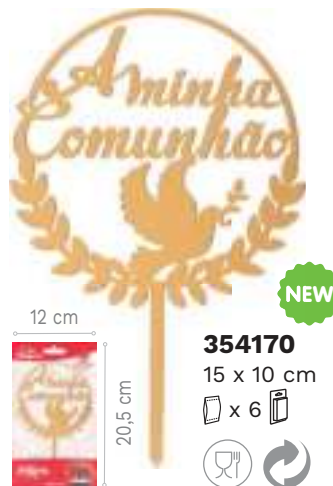

354170
15 x 10 cm
x 6



354176
16 x 9,5 cm
x 6



CAKE TOPPERS

PLASTICO · PLASTIC · PLASTIQUE · PLÁSTICO · PLASTICA



NEW

354169

13 x 11 cm

📄 x 6 📄



354160

10 x 16 cm

📄 x 6 📄



NEW

354172

15 x 10 cm

📄 x 6 📄



354120

16 x 10 cm

📄 x 6 📄



350158

19 cm · 📦 24 u.



CAKE TOPPERS

PLÁSTICO · PLASTIC · PLASTIQUE · PLÁSTICO · PLASTICA



354167

14,5 x 14 cm

📄 x 6 📄



354135

16,5 x 10 cm · 📄 x 6 📄

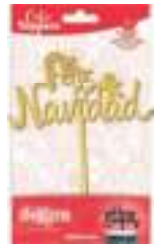

354155

11 x 14 cm · 📄 x 6 📄



354116

16,5 x 10 cm · 📄 x 6 📄



354168

17 x 8 cm · 📄 x 6 📄



CAKE TOPPERS



354107

*Plata efecto espejo
Silver mirror effect
16 x 10 cm · 6 u.



354106

*Oro efecto espejo
Gold mirror effect
16 x 10 cm · 6 u.



305062

20 x 16 cm
2 x 2 u.
© Dekora



305063

20 x 16 cm
2 x 2 u.
© Dekora



305199

10 cm · 6 u.
© Dekora



305070

METAL
19 x 19 cm
2 x 2 u.
© Dekora



CAKE TOPPERS

METAL



305109

18 cm ·  x  1 u.

© Dekora



305115

18 cm ·  x  1 u.

© Dekora



305102

18 cm ·  x  1 u.

© Dekora



305107

18 cm ·  x  1 u.

© Dekora

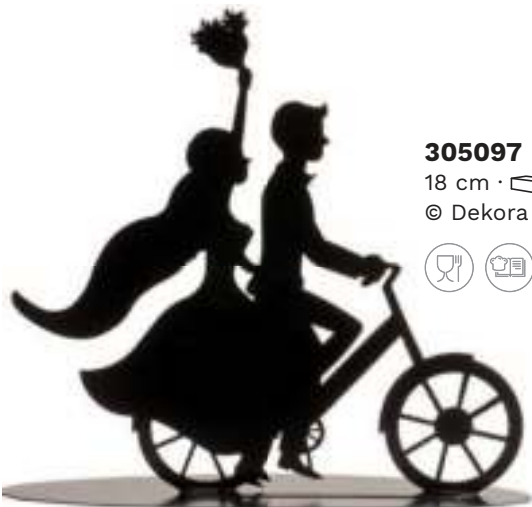

305097

18 cm ·  x  2 u.

© Dekora



305100

18 cm ·  x  1 u.

© Dekora



CAKE TOPPERS

METAL



354121
11,5 cm
x 4 u.
© Dekora



354122
12 x 11,5 cm
x 4 u.
© Dekora



Envasado individual

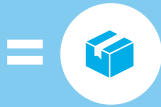

Individual packaging



354129
12 x 12,5 cm · x 4 u.



354130
12 x 12,5 cm · x 4 u.



354125
12 x 12,5 cm · x 4 u.
© Dekora



354128
12 x 12,5 cm · x 4 u.



CAKE TOPPERS

27,5 cm





15 cm





16,5 cm

359011
MICKEY & MINNIE
17,5 cm

 x 18 



359012
PAW PATROL
16,5 cm

 x 18 





NEW

359016
PEPPA PIG

16,5 cm

📦 x 18 📄



359013
TESIA

16,5 cm

📦 x 18 📄



CAKE TOPPERS





NEW

359026

STITCH

16,5 cm

 x 18 



NEW

359020

SPIDEY

16,5 cm

 x 18 



CAKE TOPPERS



359008

MICKEY

🍴 x 30 u.

📦 x 12 📦



359010

TESIA

🍴 x 30 u.

📦 x 12 📦



NEW

359024

PIRATAS

🍴 x 30 u.

📦 x 12 📦



CAKE TOPPERS



NEW

359009

MINNIE

🍷 x 16 u.

📦 x 15



NEW

359017

PEPPA PIG

🍷 x 16 u.

📦 x 15



NEW

359025

STITCH

🍷 x 16 u.

📦 x 15



CAKE TOPPERS



NEW

359000
FROZEN

🍷 x 16 u.

📦 x 15 📱



NEW

359001
PAW PATROL

🍷 x 16 u.

📦 x 15 📱



NEW

354165
SPIDEY

🍷 x 16 u.

📦 x 15 📱



CAKE TOPPERS



354163
 9 x 4,5 cm
 ☯ x 16 u.
 📄 x 15 📄
 ☯ ☯



354138
 6,5 cm
 ☯ x 48 u.
 ☯ ☯



354164
 9 x 6 cm
 ☯ x 16 u.
 📄 x 15 📄
 ☯ ☯



354139
 9 x 6 cm
 ☯ x 48 u.
 ☯ ☯

Velas y bengalas

Candles + Sparkles

Bougies + Bougies fontaines

Velas + foguetes . Candele + Bengala



deKora

Special moments

VELAS



Candles · Bougies · Candeles

2D



345404

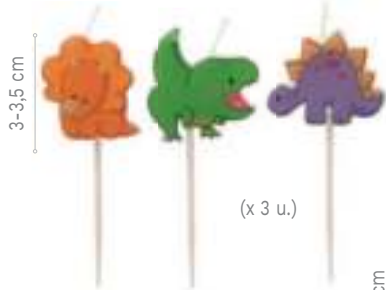

DINOS 2D

3,3 - 5 cm ·  x 8 



345407

MIX VELAS DINOSAURIO 2D

3 - 5 cm ·  x 12 



VELAS

Candles · Bougies · Candeles



2D



NEW

346232

STICH 2D

4,5 cm ·  x 8 



DISPONIBLE EN MARZO

Available March



NEW

346238

SPIDEY 2D

4 cm ·  x 8 



DISPONIBLE EN MARZO

Available March



VELAS

Candles · Bougies · Candeles

2D / 3D



346027

MICKEY 3D

8 cm ·  x 6 



VELAS

Candles · Bougies · Candele

2D / 3D



346215



CARS 2D

7,5 cm ·  x 12 



346053

CARS 3D

8,5 x 6 cm ·  x 6 



VELAS

Candles · Bougies · Candeles

2D





346245
PAW PATROL 2D
Ø 3 cm ·  x 12 



346226
PAW PATROL 2D
7 cm ·  x 12 



346170
PAW PATROL 3D
7 cm ·  x 6 



VELAS



Candles · Bougies · Candeles

2D / 3D



346249

PAW PATROL 2D

4,2 - 4,4 cm ·  x 8 



346171

SKYE 2D

7,5 cm ·  x 12 



346181

SKYE 3D

7 cm ·  x 6 



VELAS

Candles · Bougies · Candeles

2D / 3D



346224
MINNIE 2D
6,5 cm ·  x 12 



8,5 cm



346028
MINNIE 3D
8 cm ·  x 6 



VELAS

Candles · Bougies · Candele



2D / 3D



Peppa Pig

346248

PEPPA PIG 2D

4,4 - 5 cm ·  x 8 



Peppa Pig

346089

PEPPA PIG 3D

7,5 cm ·  x 6 



VELAS

Candles · Bougies · Candeles

2D



HELLO KITTY





346220
HELLO KITTY 2D
7 cm ·  x 12 



Shimmer & Shine



346203
SHIMMER & SHINE 2D
7,5 cm ·  x 12 



VELAS

Candles · Bougies · Candele

2D

**Tesia
& friends**



345413
TESIA 2D

7,5 cm ·  x 12 



3-3,5 cm



(x 3 u.)

345408
MIX VELAS UNICORNIO 2D

3 - 5 cm ·  x 12  x 15 



5 cm



(x 12 u.)



**Tesia
& friends**



345405
TESIA 2D

8 x 6,2 cm ·  x 8 



VELAS



Candles · Bougies · Candeles

2D



345417
HAPPY BIRTHDAY II
10 x 6 cm ·  x 12 



345415
HAPPY BIRTHDAY
10 x 6,5 cm ·  x 12 



VELAS



Candles · Bougies · Candeles

2D



345403

BABY 2D

4,2 - 4,4 cm ·  x 8 





VELAS

Candles · Bougies · Candeles

2D

VELAS COMIC AZUL BEBÉ

Blue Comic Candles - Bougies Comic bleues

3 x 5 cm · x 12



345430

345431

345432

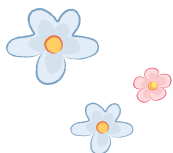
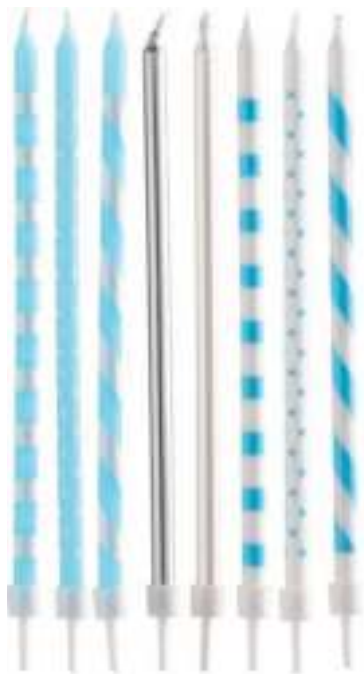

345448
13 cm · x 12









VELAS

Candles · Bougies · Candele

2D

VELAS COMIC ROSA BEBÉ

Pink Comic Candles - Bougies Comic roses

3 x 5 cm ·  x 12   



345414



345418



345419



345447

13 cm ·  x 12 



VELAS

Candles · Bougies · Candeles



345449

2D

7,5 cm ·  x 12 



345255

2D

7 cm ·  x 12 



345256

2D

7 cm ·  x 12 



345257

2D

7 cm ·  x 12 



345260

2D

7 cm ·  x 12 



VELAS

Candles · Bougies · Candeles



345261

2D

7 cm · x 12



345262

2D

7 cm · x 12



345263

2D

7 cm · x 12



345264

2D

7 cm · x 12



345265

2D

7 cm · x 12



345266

2D

7 cm · x 12



VELAS

Candles · Bougies · Candeles

2D / 3D



Disney
CINDERELLA

346127



CINDERELLA 2D

8 cm ·  x 12 



346175

DISNEY PRINCESS

9 cm ·  x 12  x 8 u.



346194

CENICIENTA 3D

5,5 cm ·  x 8 



VELAS

Candles · Bougies · Candele

2D / 3D



346002

BELLA 2D

7,5 cm ·  x 12 





Disney PRINCESS



346206

BELLA 3D

5,5 cm ·  x 8 



VELAS

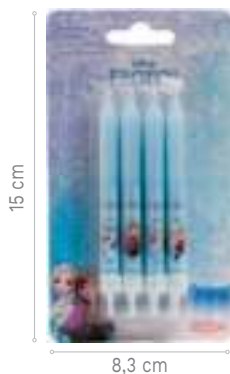

Candles · Bougies · Candeles

2D / 3D



346174

FROZEN

9 cm ·  x 12  x 8 u.



VELAS

Candles · Bougies · Candeles

2D



346228

FROZEN 2D

7 cm ·  x 12 



Disney
FROZEN



346227

FROZEN 2D

7,5 cm ·  x 12 



VELAS



Candles · Bougies · Candeles

2D / 3D



346193

SPIDER-MAN

9 cm ·  x 12  x 8 u.

MARVEL
SPIDER-MAN



MARVEL
SPIDER-MAN

346208

SPIDER-MAN 2D

7 cm ·  x 12  u.



MARVEL
SPIDER-MAN

346205

SPIDER-MAN 3D

9 cm ·  x 6  u.



VELAS

Candles · Bougies · Candele



2D



AVENGERS

346192

AVENGERS

9 cm ·  x 12  x 8 u.



AVENGERS

346185

CAPTAIN

AMERICA 2D

7,5 cm ·  x 12  u.



AVENGERS

346221

HULK 2D

7,5 cm ·  x 12  u.



VELAS

Candles · Bougies · Candeles

2D / 3D



345375

2D

 x 12  x 4 u.



345315

 x 12  x 12 u.

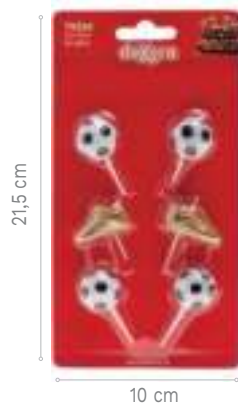

345335

3D

3 - 5 cm

 x 12  x 6 u.



VELAS

Candles · Bougies · Candele

2D



345398

6,3 cm ·  x 12 



345399

6,3 cm ·  x 12 





345400

6,3 cm ·  x 12 





345401

6,3 cm ·  x 12 



345402

6,3 cm ·  x 12 



LA VELA QUE NO SE APAGA

The candle that never goes out
La bougie qui ne s'éteint jamais
A vela que nunca sai
La candela che non si spegne mai



345310

VELA MÁGICA

Magic candle

Bougie magique

Candela magica

 x 18  x 10 u.



345311

 (50A + 50B)

A: Rosa - Pink - Rose

B: Azul - Blue - Bleu



345309

 x 12  x 24 u.



345333



VELAS LLAMA DE COLOR

Colour flame candles

Bougies à flamme colorée

Velas chama de cores

Candele con fiamma colorata

6 cm  x 12  x 6 u.



VELAS

Candles · Bougies · Candeles



345443

10 cm ·  x 12 

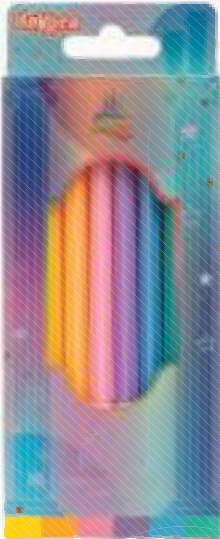



345444

12 cm ·  x 12 



345446

2,3 x 3,3 cm

 x 12 



VELAS

Candles · Bougies · Candele

VELAS METÁLICAS

Metallic candles - Bougies metalliques - Candele metalliche





345329

13 cm  x 12  x 16 u.





345330

13 cm
 x 12  x 16 u.



345332



13 cm
 x 12  x 16 u.





VELAS

Candles · Bougies · Candele



NEW 345445
14 cm ·  x 12 



NEW 345474
14 cm ·  x 12 



VELAS

Candles · Bougies · Candele

Disney
**MICKEY
MOUSE**



NEW

8,5 cm ·  x 12 



346251



346252



346253



346254



346255



346256



346257



346258



346259



346260

Doble deseo

Double wish

Vela Solidaria / Solidarity candle



MECHAS DESEOS 2 WICKS WISHES

Sopla una mecha por ti y otra por un niño con una enfermedad grave.

*Doble deseo.
Doble ilusión.*

Blow out one wick for yourself and other for a child with a serious illness.

*Double wish.
double illusion.*



345412

9,5 cm ·  x 8 





Doble Deseo

Double wish

Vela Solidaria / Solidarity candle



A veces cumplir el deseo de un niño es su mejor medicina.

La Fundación Pequeño Deseo y Dekora se han unido para crear unas velas muy especiales con 2 mechas (doble deseo). Estas velas tienen una condición muy importante, y es que cada vez que se soplen las 2 mechas, al menos 1 deseo se va a cumplir seguro, ya que, con el dinero recaudado ayudaremos a la Fundación Pequeño Deseo a que pueda seguir mejorando el estado anímico de niños y niñas con enfermedades graves a través del cumplimiento de su mayor deseo y así ayudarles a afrontar con más fuerza su tratamiento.

Sometimes fulfilling a child's wish is his best medicine.

The Pequeño Deseo Foundation and Dekora have joined forces to create very special candles with 2 wicks (double wish). These candles come with a very important condition, and that is that every time both wicks are blown out, at least 1 wish will come true for sure, as the money raised will help the Pequeño Deseo Foundation continue to improve the emotional well-being of children with serious illnesses by fulfilling their greatest wish and thus helping them better cope with their treatment.

6 X 6 cm · x 12



345451

345452

345453



345454

345455

345456



345457

345458

345459

345450



VELAS

Candles · Bougies · Candeles

VELAS GIGANTES

Giant candles - Bougies géantes - Candeles giganti

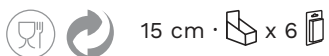

15 cm



345278



345279



345280



345281



345282



345283



345284



345285



345286



345277







VELAS

Candles · Bougies · Candele

VELAS COMIC

Comic Candles - Bougies Comic

  5,5 x 3 cm ·  x 12 



345172



345173



345174



345175



345176



345177



345178



345179



15 cm

8,3 cm



345180



345181



345055

VELAS

Candles · Bougies · Candeles

VELAS COMIC ORO

Gold Comic Candles - Bougies Comic D'or

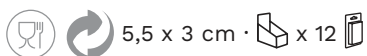

345420



345421



345422



345423



345424



345425



345426



345427



345428



345429



VELAS

Candles · Bougies · Candele

VELAS COMIC PLATA

Silver Comic Candles - Bougies Comic argentées



5,5 x 3 cm · 12 x 12



345388



345389



345390



345391



345392



345393



345394



345395



345396



345397



15 cm

8,3 cm

15,6 cm



9,8 cm

VELAS

Candles · Bougies · Candele

VELAS FLUORESCENTES

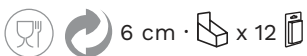
Fluorescent candles - Bougies fluorescent - Candele fluorescenti

 6 cm ·  x 12 

6 cm



345267



345268



345269



345270



345271



345272



345273



345274



345275



345276

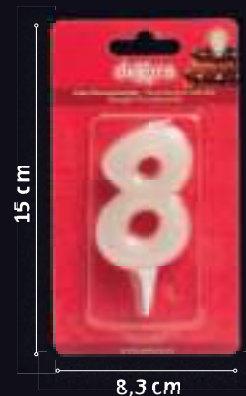

VELAS

Candles · Bougies · Candele

VELAS PURPURINA ROSA

Pink glitter candles - Bougies à paillettes couleur roses - Velas com purpurina e rosa
Candela porporina rosa

7 cm ·  x 12   

6,8 cm



345340



345341



345342



345343



345344



345345



345346



345347



345348



345349



15,6 cm

9,8 cm



8,8 cm



14,9 cm

VELAS

Candles · Bougies · Candeles

VELAS HELVET

Helvet Candles - Bougies Helvet

4,5 x 3,5 cm ·  x 12 



345075



345076



345077



345078



345079



345080



345081



345082



345083





345084



NUEVAS VELAS DE CUMPLEAÑOS CHISPEANTES

Gold birthday candles sparkling - Bougies d'anniversaire pétillantes or
Velas de aniversário de ouro espumante - Candele di compleanno in oro scintillante

0,17 g pólvora - Gunpowder

Poudre - Polvere x u. 12 cm  x 10 



1.4S

±20 s.



345433



345434



345435



345436

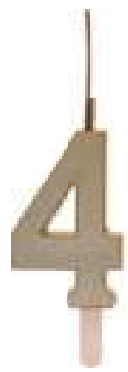

345437



345438



345439



345440



345441



345442



2 IN 1
DUO



BENGALA



VELA



YouTube



VELAS

Candles · Bougies · Candeles

VELAS BENGALA

Sparkler candles - Bougies fontaine - Velas foguete - Candeles bengala

12 cm  x 12   



345299

12 cm  x 12 u.



345300

12 cm  x 12 u.



345301

12 cm  x 12 u.



345302

12 cm  x 12 u.



345303

12 cm  x 12 u.



345304

12 cm  x 12 u.

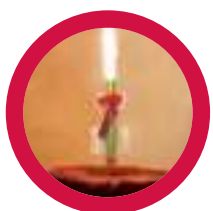

345305

12 cm  x 12 u.



345306

12 cm  x 12 u.



345307

12 cm  x 12 u.



345308

12 cm  x 12 u.

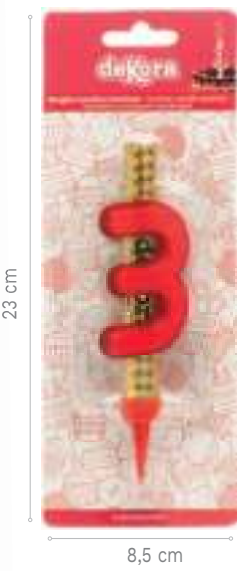

2,2 g de pólvora
gunpowder / poudre / polvere x u.



1.4S



± 35 s.



Apto para contacto alimentario - Suitable for food contact - Adapté au contact alimentaire - Adequado para contato alimentar - Idoneo al contatto con alimenti

VELAS

Candles · Bougies · Candeles

BENGALAS

Candle sparkler - Fontaine lumineuse - Foguete



± 45 s.

1.4S

316004

4,1 g pólvora - Gunpowder
Poudre - Polvere x u.

12 cm · x 12

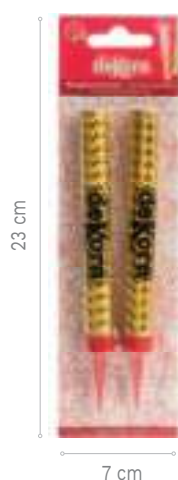

± 45 s.

1.4S

345372

4,1 g pólvora - Gunpowder
Poudre - Polvere x u.

12 cm x 12 x 2

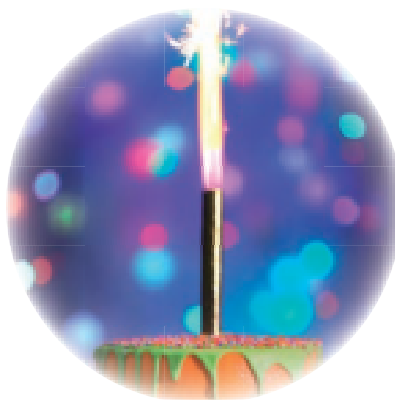

± 55 s.

1.4S

345015

4,1 g pólvora - Gunpowder
Poudre - Polvere x u.

12 cm · x 10 u.



Apto para contacto alimentario - Suitable for food contact - Adapté au contact alimentaire - Adequado para contato alimentar - Idoneo al contatto con alimenti



VELAS

Candles · Bougies · Candeles



316001

0,5 g de pólvora - Gunpowder - Poudre - Polvere x u.

17 cm  x 25  x 12 u



 **No apto para el contacto alimentario***

 Not suitable for food contact*

 Non apte au contact alimentaire*

 Não apto para o contacto alimentar*

 Non idoneo al contatto con alimenti*



1.4S

± 35 s.



1.4S

± 35 s.

316000

0,5 g de pólvora - Gunpowder - Poudre - Polvere x u.

17 cm ·  x 120 u.



No apto para el contacto alimentario*



Not suitable for food contact*



Non apte au contact alimentaire*



Não apto para o contacto alimentar*



Non idoneo al contatto con alimenti*



1.4S

± 35 s.

316002

1 g de pólvora - Gunpowder - Poudre - Polvere x u.

13,5 cm ·  x 20 u.



No apto para el contacto alimentario*



Not suitable for food contact*



Non apte au contact alimentaire*



Não apto para o contacto alimentar*



Non idoneo al contatto con alimenti*





VELAS

Candles · Bougies · Candeles



316003

0,5 g de pólvora - Gunpowder - Poudre
Polvere x u.

17 cm ·  x 25  x 8 u.



± 35 s.

1.4S

 **No apto para el contacto alimentario***

 Not suitable for food contact*

 Non apte au contact alimentaire*

 Não apto para o contacto alimentar*

 Non idoneo al contatto con alimenti*

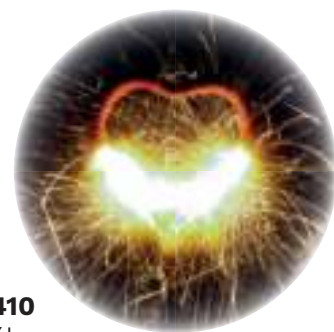
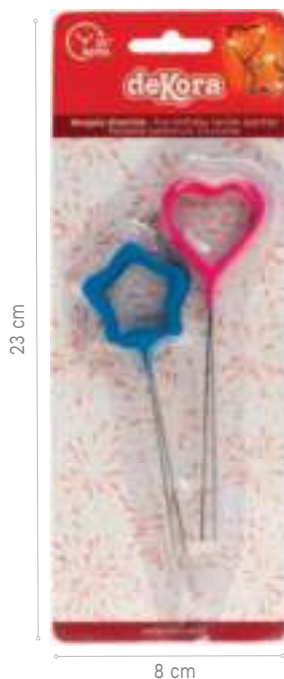

345410

1 g pólvora
Gunpowder
Poudre
Polvere x u.

13,5 cm ·  x 12  x 4 u.



± 30 s.

1.4S

 **No apto para el contacto alimentario***

 Not suitable for food contact*

 Non apte au contact alimentaire*

 Não apto para o contacto alimentar*

 Non idoneo al contatto con alimenti*

VELAS

Candles · Bougies · Candeles

BENGALAS

Candle sparkler - Fontaine lumineuse - Foguete



NEW

345460

4,1 g pólvora - Gunpowder

Poudre - Polvere x u.

12 cm ·  x 60 u.



1.4S



± 60 s.



Eventos

Events · Évènements
Eventos · Eventi



deKora

Special moments

BODA

Weddings · Mariage · Nozze

RESINA · RESIN · RÉSINE · RESINA



305111

16 cm ·  x  1 u.

© Dekora



305113

16 cm ·  x  1 u.

© Dekora



305101

16 cm ·  x  1 u.

© Dekora



305103

16 cm ·  x  1 u.

© Dekora





BODA

Weddings · Mariage · Nozze

RESINA · RESIN · RÉSINE · RESINA





305104

16 cm ·  x  1 u.
© Dekora





NEW

305119

16 cm ·  x  1 u.
© Dekora





305080

16 cm ·  x  1 u.
© Dekora



305081

16 cm ·  x  1 u.
© Dekora



BODA

Weddings · Mariage · Nozze

RESINA · RESIN · RÉSINE · RESINA



305072

12 cm

☞ x ☞ 2 u.

© Dekora



NEW

305120

16 cm · ☞ x ☞ 1 u.

© Dekora



305108

16 cm · ☞ x ☞ 1 u.

© Dekora



305074

14 cm · ☞ x ☞ 1 u.

© Dekora



CLAY · HECHO A MANO · HAND MADE · FAIT À LA MAIN · FEITO A MÃO · FATTO A MANO



305052

CLAY

13 cm · ☞ 2 u.

© Dekora



305030

CLAY

14 cm · ☞ 2 u.

© Dekora



BODA

Weddings · Mariage · Nozze

RESINA · RESIN · RÉSINE · RESINA



305096

16 cm ·  x  2 u.

© Dekora





305226

17 cm ·  x  2 u.

© Dekora



305069

18 x 15 cm ·  x  2 u.

© Dekora





BODA

Weddings · Mariage · Nozze

RESINA · RESIN · RÉSINE · RESINA





305068

20 cm ·  x  1 u.

© Dekora



305133

18 x 19 cm ·  x  1 u.

© Dekora



305066

20 cm ·  x  2 u.

© Dekora



305000

16 cm ·  x  1 u.

© Dekora



305058

18 cm ·  x  1 u.

© Dekora



305060

18 cm ·  x  2 u.

© Dekora



BODA

Weddings · Mariage · Nozze

RESINA · RESIN · RÉSINE · RESINA



NEW

305124

18 cm ·  x  1 u.

© Dekora



NEW

305125

18 cm ·  x  1 u.

© Dekora



305010

20 cm ·  x  2 u.

© Dekora



305001

20 cm ·  x  1 u.

© Dekora



305065

20 cm ·  x  1 u.

© Dekora



305067

20 cm ·  x  2 u.

© Dekora



BODA

Weddings · Mariage · Nozze

RESINA · RESIN · RÉSINE · RESINA



305082

16 cm ·  x  2 u.

© Dekora



305086

16 cm ·  x  2 u.

© Dekora



305090

16 cm ·  x  2 u.

© Dekora



305083

16 cm ·  x  2 u.

© Dekora



305088

16 cm ·  x  2 u.

© Dekora



305087

16 cm ·  x  2 u.

© Dekora





BODA



Weddings · Mariage · Nozze

RESINA · RESIN · RÉSINE · RESINA



305054
20 cm ·  x  2 u.
© Dekora



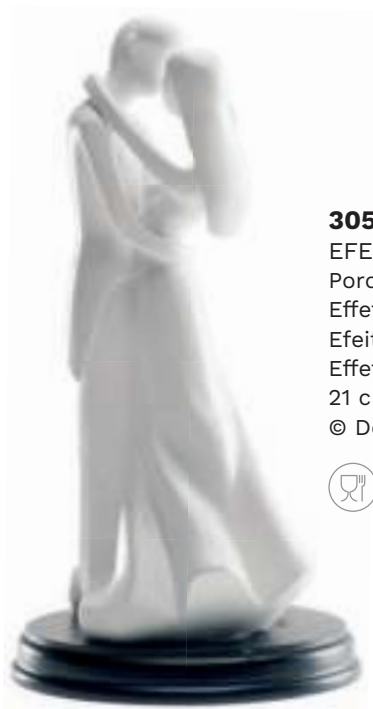

305008
20 cm ·  x  1 u.
© Dekora



305217
EFECTO PORCELANA
Porcelain effect
Effet porcelaine
Efeito porcelana
Effetto porcellanato
21 cm ·  1 u.
© Dekora



305224
20 cm ·  x  1 u.
© Dekora





305057
METAL
18 cm · 2 u.
© Dekora



305056
METAL
18 cm · 2 u.
© Dekora



354107
*Plata efecto espejo
Silver mirror effect
16 x 10 cm · x 6



354106
*Oro efecto espejo
Gold mirror effect
16 x 10 cm · x 6



305070
METAL
19 x 19 cm
 x 2 u.
© Dekora



305199
10 cm · 6 u.
© Dekora



305062
20 x 16 cm
 x 2 u.
© Dekora



305063
20 x 16 cm
 x 2 u.
© Dekora





BODA

Weddings · Mariage · Nozze

CAKE TOPPER METAL



305109

18 cm ·  x  1 u.

© Dekora



305115

18 cm ·  x  1 u.

© Dekora

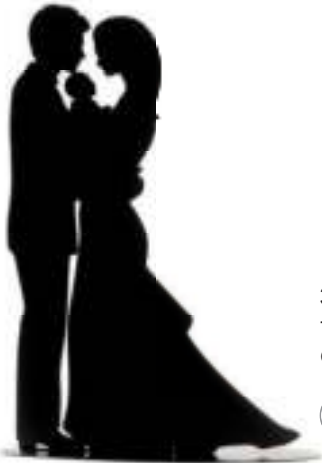

305102

18 cm ·  x  1 u.

© Dekora



305107

18 cm ·  x  1 u.

© Dekora



305097

18 cm ·  x  2 u.

© Dekora



305100

18 cm ·  x  1 u.

© Dekora



Weddings · Mariage · Nozze

SOPORTES · CAKE STANDS · SUPPORTS · SUPPORTES · SUPPORTI

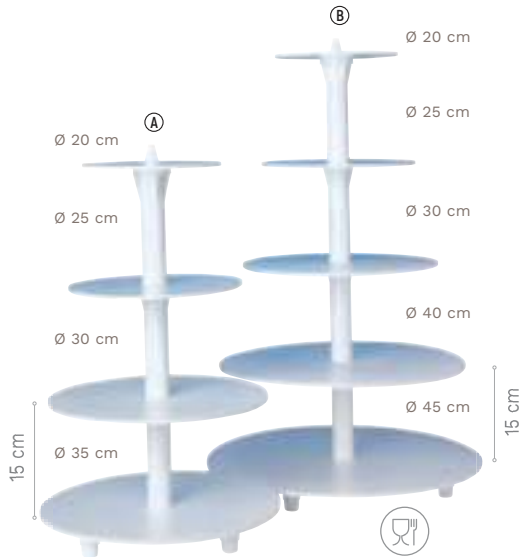

341003

A PLÁSTICO - Plastic - Plastique - Plástico
4 Pisos - Tiers - Étages - Andares - Piani
1 u.

341004

B PLÁSTICO - Plastic - Plastique - Plástico
5 Pisos - Tiers - Étages - Andares - Piani
1 u.



341001

A PLÁSTICO - Plastic - Plastique - Plástico
2 Pisos - Tiers - Étages - Andares - Piani
1 u.

341002

B PLÁSTICO - Plastic - Plastique - Plástico
3 Pisos - Tiers - Étages - Andares - Piani
1 u.



341125

PLÁSTICO - Plastic
Plastique - Plástico
2 Brazos - Supports
Bras - Suportes
H: 24 cm · 1 u.



341126

PLÁSTICO - Plastic
Plastique - Plástico
4 Brazos - Supports
Bras - Suportes
H: 45 cm · 1 u.



535230

BANDEJA DE EXPOSICIÓN
INCLINABLE GIRATORIA

Cake Display rotatory tilting
Plateau présentoir pivotant avec inclinaison
Bandeja exposição giratório de inclinação
Vassoio da esposizione inclinabile e girevole
Ø 23 cm · 1 u.



Weddings · Mariage · Nozze

SOPORTES · CAKE STANDS · SUPPORTS · SUPORTES · SUPPORTI



341153

PLÁSTICO - Plastic - Plastique - Plástico
4 Brazos - Supports
Bras - Suportes
1 u.

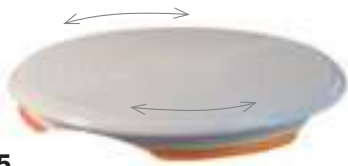

341155

GIRATORIA

Rotary - Tourante - Rotante - Rotativo
Ø 31 X H: 3,2 cm · 1 u.



535217

GIRATORIO

Rotary - Tourante - Rotante - Rotativo
Ø 32 x 10 cm · Peso / Weight: 600 g · 1 u.



CINTA STRASS · RHINESTONE WITH STRASS · BANDE AVEC STRASS



319045

H: 5 cm · 15 mts
Blanco - White



319046

H: 5 cm · 15 mts
Rosa - Pink



319044

H: 5 cm · 15 mts
Azul - Blue



319020

H: 3,5 cm
10 mts
Plata - Silver



319024

H: 3,5 cm
10 mts
Azul - Blue



319025

H: 3,5 cm
10 mts
Rosa - Pink



BODA

Weddings · Mariage · Nozze

SOPORTES · CAKE STANDS · SUPPORTS · SUPORTES · SUPPORTI

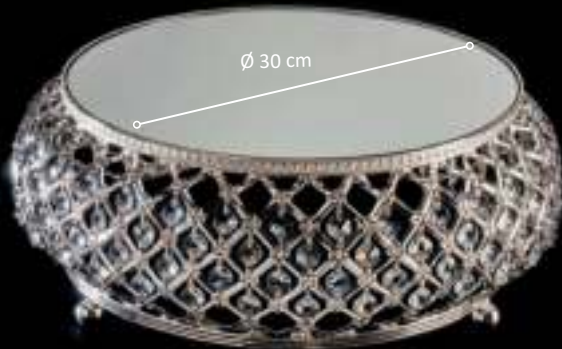

■ **SOPORTE PLATA ESPEJO Y CRISTAL** -
SILVER MIRROR AND CRYSTAL SUPPORT -
SUPPORT ARGENT AVEC MIROIR - SUPPORTO
ARGENTO SPECCHIO E CRISTALLO

342018

Ø 30 x H: 15 cm

1 u.



■ **SOPORTE CUADRADO CON DIAMANTES**

- SQUARE SUPPORT WITH DIAMONDS
- SUPPORT CARRÉ AVEC DIAMANTS -
SUPPORTO QUADRATO CON DIAMANTI

342044

21 x 21 x H: 22 cm

1 u.

342042

25 x 25 x H: 32 cm

1 u.



■ **SOPORTE REDONDO CON DIAMANTES** - ROUND
SUPPORT WITH DIAMONDS - SUPPORT ROND AVEC
DIAMANTS - SUPPORTO ROTONDO

342033

Ø 25 cm - H: 32 cm

1 u.

342023

Ø 30 cm - H: 33,5 cm

1 u.



■ **MINI SOPORTE NEGRO TARTA PLEXIGLÁS** -
 MINI BLACK PLEXIGLASS CAKE STAND - MINI
 SUPPORT À GÂTEAU NOIR PLEXIGLAS - MINI
 SUPORTE PRETO PARA BOLOS PLEXIGLAS -
 MINI ALZATA NERA IN PLEXIGLAS PER TORTE

341156 Ø 21 x H: 10,3 cm  1 u. **A**

341157 Ø 21 x H: 16,3 cm  1 u. **B**



■ **MINI SOPORTE BLANCO TARTA PLEXIGLÁS** - MINI
 WHITE PLEXIGLASS CAKE STAND - MINI SUPPORT
 À GÂTEAU BLANC PLEXIGLAS - MINI SUPORTE
 BRANCO PARA BOLOS PLEXIGLAS - MINI ALZATA
 BIANCA IN PLEXIGLAS PER TORTE

341158 Ø 21 x H: 10,3 cm  1 u. **A**

341159 Ø 21 x H: 16,3 cm  1 u. **B**





■ **SOPORTE CRYSTAL BARROCO PLEXIGLÁS**
 - CRYSTAL BAROQUE PLEXIGLASS STAND
 - SUPPORT CRYSTAL BAROQUE PLEXIGLAS
 - SUPORTE CRYSTAL BARROCO PLEXIGLAS -
 SUPPORTO CRYSTAL BAROCCO IN PLEXIGLAS

341161 Ø 26 x H: 35 cm  1 u.



■ **SOPORTE NEGRO BARROCO PLEXIGLÁS**
 - BLACK BAROQUE PLEXIGLASS STAND
 - SUPPORT NOIR BAROQUE PLEXIGLAS -
 SUPORTE PRETO BARROCO PLEXIGLAS -
 SUPPORTO NERO BAROCCO PLEXIGLAS

341162 Ø 26 x H: 21 cm  1 u. **A**

341163 Ø 26 x H: 35 cm  1 u. **B**



Weddings · Mariage · Nozze

SOPORTES · CAKE STANDS · SUPPORTS · SUPORTES · SUPPORTI

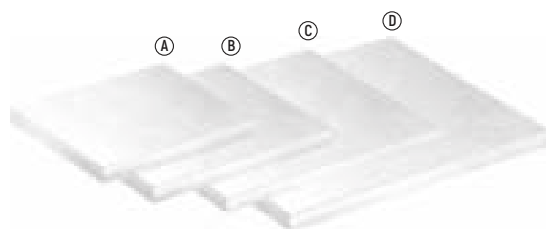

540360 25 x 25 x H: 1,2 cm **A**

540361 30 x 30 x H: 1,2 cm **B**

NEW **540362** 35,5 x 35,5 x H: 1,2 cm **C**

NEW **540363** 40 x 40 x H: 1,2 cm **D**



BLANCAS - white - blanc - branco - bianco  1 u.

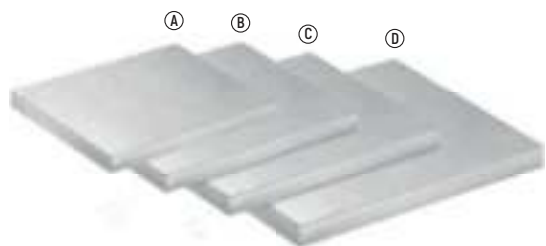

540359 25 x 25 cm x H: 1,2 cm **A**

540270 30 x 30 cm x H: 1,2 cm **B**

540075 35,5 x 35,5 cm x H: 1,2 cm **C**

540271 40 x 40 cm x H: 1,2 cm **D**



PLATA - silver - argent - prata - argento  1 u.

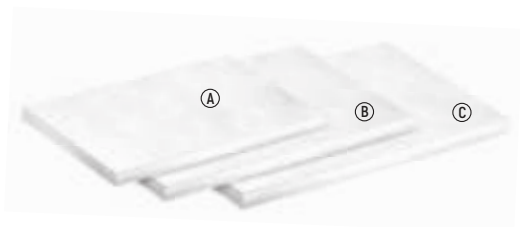

A **540365** 20 x 30 cm x H: 1,2 cm

B **540367** 35 x 30 cm x H: 1,2 cm

C **540370** 30 x 40 cm x H: 1,2 cm



BLANCAS - white - blanc - branco - bianco  1 u.

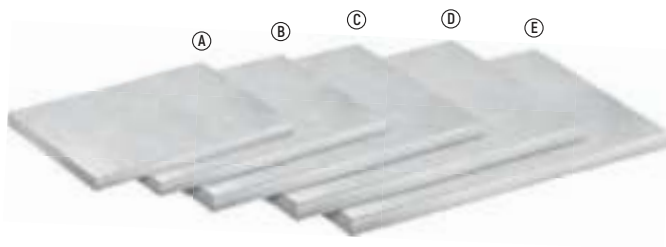

A **540364** 20 x 30 cm x H: 1,2 cm

B **540273** 30 x 25 cm x H: 1,2 cm

C **540272** 35 x 25 cm x H: 1,2 cm

D **540277** 35 x 30 cm x H: 1,2 cm

E **540371** 30 x 40 cm x H: 1,2 cm



PLATA - silver - argent - prata - argento  1 u.

BODA

Weddings · Mariage · Nozze

SOPORTES · CAKE STANDS · SUPPORTS · SUPORTES · SUPPORTI



540358 Ø 20 x H: 1,2 cm **A**

540226 Ø 25 x H: 1,2 cm **B**

540229 Ø 30 x H: 1,2 cm **C**

540236 Ø 35 x H: 1,2 cm **D**

540268 Ø 40 x H: 1,2 cm **E**

540269 Ø 45 x H: 1,2 cm **F**



PLATA - silver - argent - prata - argento 1 u.



540356 Ø 20 x H: 1,2 cm **A**

540299 Ø 25 x H: 1,2 cm **B**

540304 Ø 30 x H: 1,2 cm **C**

540305 Ø 35 x H: 1,2 cm **D**

540352 Ø 40 x H: 1,2 cm **E**



BLANCAS - white - blanc - branco - bianco 1 u.



540306 Ø 25 x H: 1,2 cm **A**

540307 Ø 30 x H: 1,2 cm **B**

540308 Ø 35 x H: 1,2 cm **C**

540353 Ø 40 x H: 1,2 cm **D**



DORADAS - gold - or - oro 1 u.



540309 Ø 25 x H: 1,2 cm **A**

540310 Ø 30 x H: 1,2 cm **B**

540311 Ø 35 x H: 1,2 cm **C**

540354 Ø 40 x H: 1,2 cm **D**



NEGRAS - black - noir - preto - nero 1 u.

FLOWERS
SIZE
XL



NEW

126176

14 cm · 1 u.



NEW

126177

14 cm · 1 u.



NEW

126175

14 cm · 1 u.

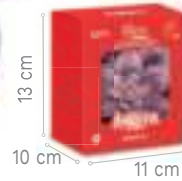

NEW

126178

13 cm · 1 u.

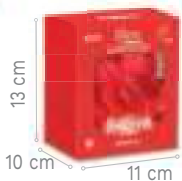

NEW

126179

13 cm · 1 u.





FLOWERS
SIZE
XL

NEW

126181

12 cm · 1 u.



NEW

126180

12 cm · 1 u.



NEW

126193

12,5 cm · 1 u.



NEW

126195

12,5 cm · 1 u.



NEW

126192

12,5 cm · 1 u.



NEW

126194

12,5 cm · 1 u.





126173

12,5 cm · 1 u.

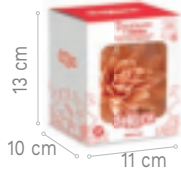

126174

12,5 cm · 1 u.

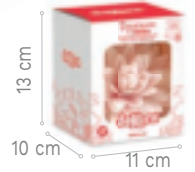

126172

12,5 cm · 1 u.

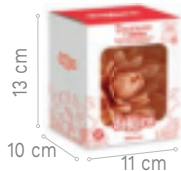

126142

12,5 cm · 1 u.

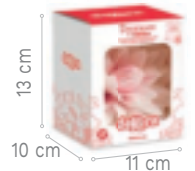



126141

12,5 cm ·  1 u.

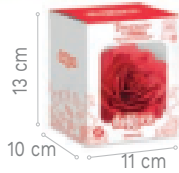

126140

12,5 cm ·  1 u.



x 6





x 4



NEW

166035

 x 12 



BAUTIZO

Christening · Baptême · Baptizado · Battesimo

RESINA · RESIN · RÉSINE · RESINA



310136

10 cm ·  x  6 u.

© Dekora



310001

10 cm ·  x  6 u.

© Dekora



310098

10 cm ·  6 u.



310124

10,5 cm ·  x  6 u.

© Dekora



310097

10 cm ·  6 u.





BAUTIZO

Christening · Baptême · Baptizado · Battesimo

RESINA · RESIN · RÉSINE · RESINA





310114

10 x 6 cm ·  x  1 u.

© Dekora



310144

10 x 6 x 7 cm ·  x  1 u.

© Dekora



NEW





310134

10 cm ·  x  6 u.

© Dekora



310145

10,5 x 6 cm ·  x  1 u.

© Dekora



NEW



BAUTIZO

Christening · Baptême · Baptizado · Battesimo

RESINA · RESIN · RÉSINE · RESINA



310110

10 cm ·  x  1 u.

© Dekora

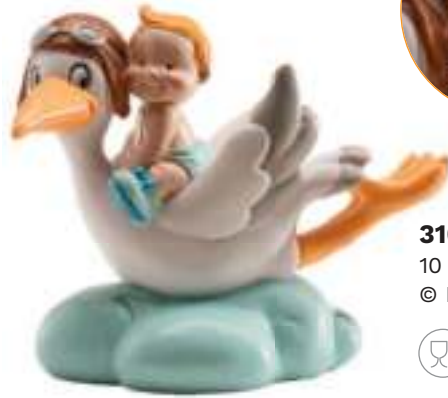

310112

10 cm ·  x  4 u.

© Dekora



310107

METAL

18 cm ·  4 u.

© Dekora



310048

14,5 cm ·  4 u.

© Dekora



BAUTIZO



Christening · Baptême · Baptizado · Battesimo

RESINA · RESIN · RÉSINE · RESINA



310105



13 x 10 cm

 x  4 u.

© Dekora



310103

13 x 10 cm ·  x  4 u.

© Dekora



310138

10 cm ·  x  6 u.

© Dekora



310137

10 cm ·  x  1 u.

© Dekora



BAUTIZO

Christening · Baptême · Baptizado · Battesimo

RESINA · RESIN · RÉSINE · RESINA



310111

10 cm ·  x  1 u.

© Dekora



310113

10 cm ·  x  1 u.

© Dekora



310108

METAL

18 cm ·  4 u.

© Dekora



310047

14,5 cm ·  4 u.

© Dekora



BAUTIZO

Christening · Baptême · Baptizado · Battesimo

RESINA · RESIN · RÉSINE · RESINA

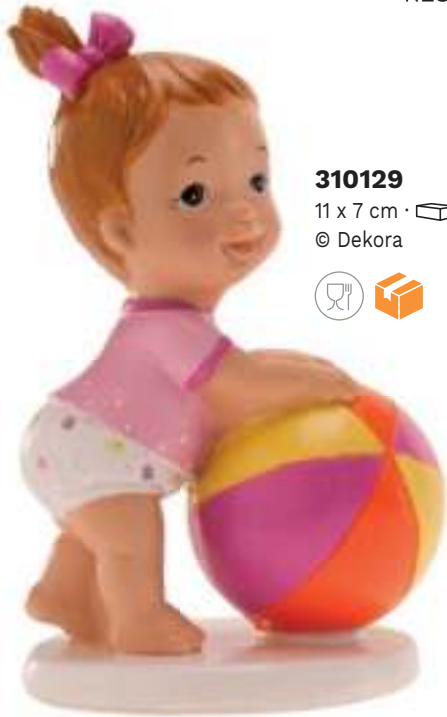

310129



11 x 7 cm ·  x  6 u.

© Dekora



NEW

310146

10,5 x 6 cm ·  x  1 u.

© Dekora



310123

10,5 cm ·  x  1 u.

© Dekora



BAUTIZO

Christening · Baptême · Baptizado · Battesimo

RESINA · RESIN · RÉSINE · RESINA



310140

10 cm ·  6 u.

© Dekora



310135

10 cm ·  x  6 u.

© Dekora



310002

10 cm ·  x  6 u.

© Dekora



BAUTIZO



Christening · Baptême · Baptizado · Battesimo

RESINA · RESIN · RÉSINE · RESINA



NEW

310143

10 x 6 x 7 cm ·  x  1 u.

© Dekora





310133

10 cm ·  x  6 u.

© Dekora



310115

10 x 6 cm ·  x  1 u.

© Dekora



BAUTIZO

Christening · Baptême · Baptizado · Battesimo



354162
10 x 15,6 cm
📏 x 6 📏



354161
10 x 14,3 cm
📏 x 6 📏

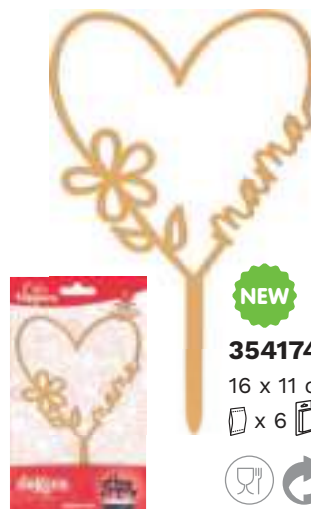

NEW

354174
16 x 11 cm
📏 x 6 📏



354119
16 x 6 cm
📏 x 6 📏



354151
17 x 10 cm
📏 x 6 📏



354108
*Plata efecto espejo
Silver mirror effect
16 x 10 cm · 📏 x 6 📏



310004
10 cm · 📦 6 u.
© Dekora

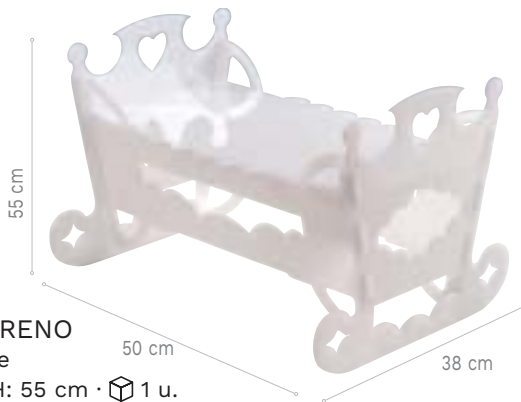

341081
POLIESTIRENO
Polystyrene
50 x 38 x H: 55 cm · 📦 1 u.



BAUTIZO

Christening · Baptême · Baptizado · Battesimo

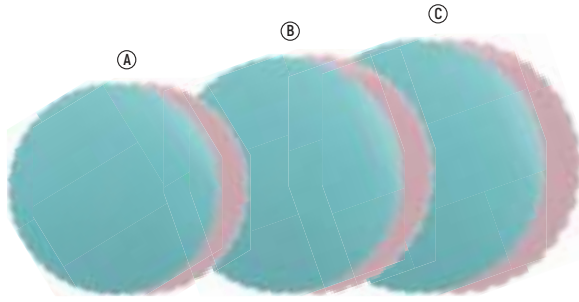

DOBLE CARA

Doble cara - Double face - Duas caras - Doppia faccia

540296 0,3 Ø 25 cm  1 u. **A**

540297 0,3 Ø 30 cm  1 u. **B**

540298 0,3 Ø 35 cm  1 u. **C**



345447

13 cm ·  x 12 





345448

13 cm ·  x 12 



345403

BABY 3D

4,2 - 4,4 cm ·  x 8 



BAUTIZO

Christening · Baptême · Baptizado · Battesimo



401030
ROSA
Pink - Rose - Rosa



401031
AZUL
Blue - Bleu
Azul - Blu



401032
AMARILLO
Yellow - Jaune
Amarelo - Giallo



CHOCO DRIP

180 g · 1 u.



126006
OBLEA
Wafer - Azyme
Obreia - Cialda
8 cm · 50 u.



NEW 126190
4 cm · 18 u.



NEW 126191
4 cm · 18 u.

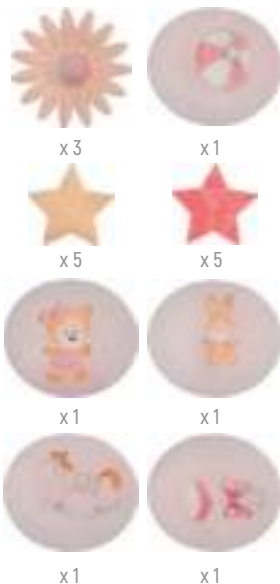

NEW 166037
x 12

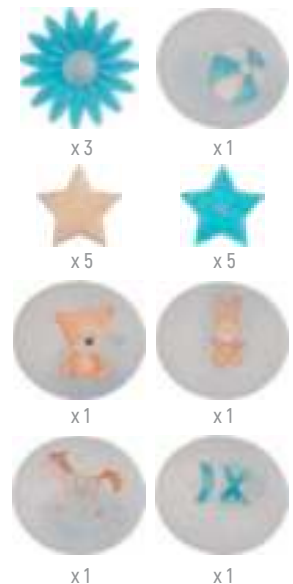

NEW 166036
x 12



BAUTIZO & COMUNIÓN

Christening · Baptême · Baptizado · Battesimo
Holy Communion · Communion · Comunhão · Comunione

AZÚCAR · SUGAR · SUCRE · AÇUCAR · ZUCCHERO



NEW
230074
 x 12



NEW
230073
 x 12





COMUNIÓN



Holy Communion · Communion · Comunhão · Comunione

RESINA · RESIN · RÉSINE · RESINA





315111
16 cm ·  x  6 u.
© Dekora





315118
16 cm ·  x  6 u.
© Dekora

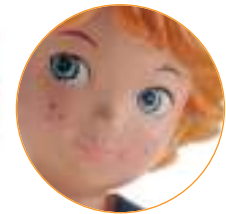

315117
16 cm ·  x  6 u.
© Dekora



315112
16 cm ·  x  6 u.
© Dekora



COMUNIÓN

Holy Communion · Communion · Comunhão · Comunione

RESINA · RESIN · RÉSINE · RESINA



315108

13 cm ·  x  6 u.

© Dekora



315109

13 cm ·  x  6 u.

© Dekora



315125

16 cm ·  x  6 u.

© Dekora



315099

15 cm ·  x  6 u.

© Dekora



COMUNIÓN

Holy Communion · Communion · Comunhão · Comunione

RESINA · RESIN · RÉSINE · RESINA



NEW

315127

16 cm ·  x  6 u.

© Dekora



315101

13 cm ·  x  6 u.

© Dekora



315081

12 cm ·  6 u.

© Dekora



NEW

315128

16 cm ·  x  6 u.

© Dekora

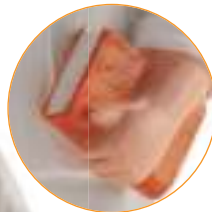

315110

16 cm ·  x  6 u.

© Dekora



315105

15 cm ·  x  1 u.

© Dekora



COMUNIÓN

Holy Communion · Communion · Comunhão · Comunione

RESINA · RESIN · RÉSINE · RESINA



315095
13 cm ·  6 u.
© Dekora



315007
13 cm ·  6 u.
© Dekora



315055
METAL
16 cm ·  4 u.
© Dekora



308002
8 cm ·  x 6 
© Dekora



315048
8 cm ·  6 u.
© Dekora



COMUNIÓN

Holy Communion · Communion · Comunhão · Comunione

RESINA · RESIN · RÉSINE · RESINA



315123

16 cm ·  x  6 u.

© Dekora



315119

16 cm ·  x  6 u.

© Dekora



315122

16 cm ·  x  1 u.

© Dekora



315120

16 cm ·  x  6 u.

© Dekora





COMUNIÓN



Holy Communion · Communion · Comunhão · Comunione

RESINA · RESIN · RÉSINE · RESINA





315114
16 cm ·  x  6 u.
© Dekora



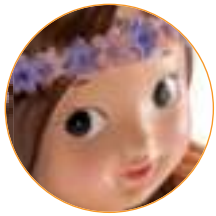

315106
13 cm ·  x  6 u.
© Dekora



315104
15 cm ·  x  6 u.
© Dekora



315115
16 cm ·  x  6 u.
© Dekora





COMUNIÓN

Holy Communion · Communion · Comunhão · Comunione

RESINA · RESIN · RÉSINE · RESINA



315098

15 cm ·  x  6 u.
© Dekora



315096

13 cm ·  6 u.
© Dekora



315082

12 cm ·  6 u.
© Dekora



308003

8 cm ·  x  6 u.
© Dekora



315049

8 cm ·  6 u.
© Dekora



COMUNIÓN

Holy Communion · Communion · Comunhão · Comunione

RESINA · RESIN · RÉSINE · RESINA



315113

16 cm ·  x  6 u.

© Dekora

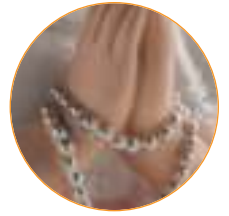

NEW

315129

16 cm ·  x  1 u.

© Dekora



315100

13 cm ·  x  6 u.

© Dekora



315107

13 cm ·  x  6 u.

© Dekora



NEW

315126

16 cm ·  x  1 u.

© Dekora



COMUNIÓN

Holy Communion · Communion · Comunhão · Comunione



354109

Oro efecto espejo
Gold mirror effect

16,5 x 9,9 cm · 📄 x 6 📄



NEW

354170

Oro efecto espejo
Gold mirror effect

15 x 10 cm · 📄 x 6 📄



NEW

354176

Oro efecto espejo
Gold mirror effect

16 x 9,5 cm · 📄 x 6 📄



305155

RESINA - Resin

19,5 cm · 📦 2 u.

© Dekora



315041

RESINA - Resin

11 cm · 📦 6 u.

© Dekora



Utillaje

Tools · Outillage
Utensílios · Utensili



deKora

Special moments



MANGAS PASTELERAS

Piping bags · Poche à douille · Saco pasteleiro · Tasca da pasticciere

■ SILVER

Efecto anti microbios, reduce el crecimiento de la bacteria y el mal olor (incluso después de lavarlas).

EN: Anti-microbe effect, reduces the growth of the bacteria and the bad smell (even after washing them).

FR: Effet anti-microbes, réduit l'augmentation bactérienne et les mauvaises odeurs (y compris après lavage).

PT: Efeito antimicrobiano, reduz o crescimento da bactéria e o mau odor (mesmo depois de lavar).

IT: Effetto antimicrobico, contrasta la diffusione di batteri e cattivi odori (anche dopo il lavaggio).



505088 25 cm  6 u.

505089 28 cm  6 u.

505090 34 cm  6 u.

505091 40 cm  6 u.

505093 50 cm  6 u.

505094 55 cm  6 u.

505095 60 cm  6 u.

505096 65 cm  6 u.

505097 70 cm  6 u.

505098 75 cm  6 u.

■ ALGODÓN - Cotton - Coton - Algodão - Cotone

Fabricado con múltiples recubrimientos de plástico. Punta reforzada, con costura y colgador. Garantía de THERMO.

EN: Made multiple plastic coatings. With reinforced tip. With seams and hanger. With the THERMO guarantee. **FR:** Fabrication à base de multiples revêtements en plastique. Une extrémité renforcée, avec une couture et un crochet. Garantie THERMO.

PT: Fabricado con múltiples recubrimientos de plástico. Têm a ponta reforçada, com costura e pega. Garantia THERMO. **IT:** Prodotto realizzato con differenti rivestimenti in plastica. Sono dotati di punta rinforzata con cucitura e staffa per appendere. Garanzia THERMO.



505001 34 cm  6 u.

505002 40 cm  6 u.

505003 46 cm  6 u.

505004 50 cm  6 u.

505005 55 cm  6 u.

505006 60 cm  6 u.

505007 65 cm  6 u.

505008 70 cm  6 u.

505009 75 cm  6 u.



■ POLIESTER & POLIURETANO









Polyester & Polyurethane

Ligeras y fáciles de manejar, material resistente de fibra sintética con soldadura resistente y ojal, aptas para lavavajillas.

EN: Lightweight and easy to handle, sturdy synthetic fibre material with sturdy welding and eyelet, dishwasher safe. **FR:** Léger et facile à manipuler, matériau en fibre synthétique robuste avec soudure et œillet solides, lavable au lave-vaisselle. **PT:** Leve e fácil de manusear, material de fibra sintética resistente com soldadura e ilhós resistentes, lavável na máquina de lavar louça. **IT:** Leggero e maneggevole, robusto materiale in fibra sintetica con robuste saldature e occhielli, lavabile in lavastoviglie.

NEW





505123	34 cm	 1 u.
505124	40 cm	 1 u.
505125	46 cm	 1 u.
505126	50 cm	 1 u.
505127	55 cm	 1 u.
505128	60 cm	 1 u.
505129	65 cm	 1 u.
505130	70 cm	 1 u.

■ DESECHABLES “ONE DAY” - Disponibles - Á douille - Descartáveis - Usa e getta

VENTAJAS: Transparente, higiénico, punta cerrada, adaptable a boquillas. Alta presión.

EN: ADVANTAGES: Transparent, hygienic, closed tip, adaptable to nozzles. High pressure. **FR:** AVANTAGES: Transparent, hygiénique, bout fermé, adaptable aux douilles. Haute pression. **PT:** VANTAGEN: Transparente, higiénico, ponta fechada, adaptável aos bicos. Alta pressão. **IT:** VANTAGGI: trasparente, igienico, punta chiusa, adattabile ai beccucci. Alta pressione.

505105 40 cm · 90 µ  100 u.

505106 55 cm · 90 µ  100 u.

505107 65 cm · 90 µ  100 u.



■ DESECHABLES - Disponibles - Á douille - Descartáveis - Usa e getta

505081 30 cm 75 µ  26 u.







■ **DESECHABLES KEE SEAL ULTRA** - Disposables - À douille - Descartáveis - Usa e getta

CARACTERÍSTICAS: Material rugoso. Interior estéril. Superficie exterior Ultra antideslizante para un agarre excelente. Nuevas soldaduras dobles irrompibles en cada manga para extrema resistencia y seguridad. Si la presión ejercida es demasiado extrema, una burbuja alerta al usuario. Cumple con las directivas de la UE para plásticos en contacto con alimentos. Producto de alta calidad fabricado en la UE horneable hasta 110°C, puede calentarse en el microondas y puede congelarse -30°C. • CERTIFICADO KOSHER.

EN: FEATURES: Rough material. Sterile inner side. Ultra non-slip outside surface for an excellent grip. New unbreakable double welded seams on each piping bag for extreme security and resistance. If the pressure exerted is too extreme a bubble will alert its user. It complies with the directives of the E.U. for plastics in contact with food. High quality product made in the E.U. Suitable for oven (up to 110°C). Suitable for microwave. Suitable for freezing. (down to -30°C) • KOSHER CERTIFIED.

FR: Matière rugueuse . Intérieur stérile. Surface extérieure ultra-antidérapante pour une prise optimale. Nouvelles doubles soudures incassables sur chaque manche pour une résistance et une sécurité à toute épreuve. Si la pression exercée est trop forte, une bulle avertit l'utilisateur. Produit conforme aux normes UE s'appliquant aux plastiques entrant en contact avec des aliments. Produit de grande qualité fabriqué en UE, allant au four (jusqu'à 110°C). Il peut être réchauffé au micro-ondes et il peut être congelé jusqu'à -30°C. • CERTIFIÉ CASHER. **PT:** Material rugoso. Interior estéril. Superfície exterior ultra anti-deslizante para excelente aderência. Novas soldas duplas inquebráveis em cada saco para maior resistência e segurança. Caso a pressão exercida seja demasiado forte, uma bolha irá alertar o utilizador. Em conformidade com as normas da UE para plásticos em contacto com alimentos. Produto de elevada qualidade fabricado na UE, pode ir ao forno até 110°C, pode ser aquecido no micro-ondas e pode ser congelado a -30°C • CERTIFICADO KOSHER. **IT:** CARATTERISTICHE: Materiale rugoso. Interno sterile. Superficie esterna con effetto ultra-antiscivolo per una presa ottimale. Nuove saldature doppie anti rottura su ciascuna tasca, per il massimo della resistenza e della sicurezza. Quando la pressione esercitata diventa eccessiva, una bolla avverte l'utente. Il prodotto soddisfa i requisiti delle direttive UE sui prodotti in plastica in contatto con gli alimenti. Prodotto di prima qualità, realizzato in UE, può essere riscaldato in forno fino a 110°, in microonde e può essere congelato -30°. • CERTIFICATO KOSHER.

505025 53 cm 72 µ  100 u.

505026 63 cm 72 µ  80 u.

505065 73 cm 72 µ  50 u.





BOQUILLAS ACERO INOX.

Stainless steel nozzles · Douilles en acier inox · Bicos em aço inox
Beccucci in acciaio inox.



X2

■ **LISA** - Plain - Lisses - Liso - Lisci

510083 Ø 0,3 cm 2 u.

510084 Ø 0,5 cm 2 u.

510085 Ø 0,7 cm 2 u.

510086 Ø 0,9 cm 2 u.

510087 Ø 1,1 cm 2 u.

510088 Ø 1,3 cm 2 u.

510089 Ø 1,5 cm 2 u.

510090 Ø 1,8 cm 2 u.



X2

■ **ESTRIADAS** - Drop flower - Cannelée -
Estriados - Rigati

510091 Ø 0,35 cm 2 u.

510092 Ø 0,5 cm 2 u.

510093 Ø 0,7 cm 2 u.

510094 Ø 0,9 cm 2 u.

510095 Ø 1,1 cm 2 u.

510096 Ø 1,3 cm 2 u.

510097 Ø 1,8 cm 2 u.



X6

■ **LISA** - Plain - Lisses - Liso - Lisci
510140

Ø 0,4/0,6/0,8/1/1,3/1,5 cm 6 u.
Juego 6 boquillas / Nozzles set



X6

■ **ESTRIADAS** - Grooved - Strié -
Estriados - Rigatii
510143

Ø 0,4/0,6/0,8/1/1,3/1,5 cm 6 u.
Juego 6 boquillas / Nozzles set
8 grips - 8 dentes - 8 denti



X5

■ **INJECTORA** - Injector
- injecteur - injector - Di
iniezione
535084

Ø 0,4 x 9,5 cm · 5 u.



X5

■ **SAINT HONORE**
510001

Ø 1,3 x 2 cm TOP: Ø 2,5 cm
 5 u.



X5

■ **SAINT HONORE**
510002

Ø 1,2 x 1,6 cm TOP: Ø 2,5 cm
 5 u.



X1

527278

Ø 5,5 x 6 cm TOP: Ø 3,1 cm
 1 u.

BOQUILLAS ACERO INOX.



Stainless steel nozzles · Douilles en acier inox · Bicos em aço inox
Beccucci in acciaio inox.

X1



527282

Ø 3,2 x 5,7 cm TOP: Ø 2,2 cm

1 u.

X1



527279

Ø 3,2 x 6 cm TOP: Ø 2,2 cm

1 u.

X1



527283

Ø 3,2 x 5,7 cm TOP: Ø 2,2 cm

1 u.

X1



527280

Ø 3,2 x 5,7 cm TOP: Ø 2,2 cm

1 u.

X1



527281

Ø 3,2 x 5,7 cm TOP: Ø 2,2 cm

1 u.



BOQUILLAS ACERO INOX.

Stainless steel nozzles · Douilles en acier inox · Bicos em aço inox
Beccucci in acciaio inox.

■ **KIT DE BOQUILLAS RUSAS SURTIDAS** - Russian piping tips box - Kit douilles russe assorties -
Kit de bicos russos sortido - Kit di beccucci russi assortiti



527296
Ø 2,7 x 4 cm
8 u.



527276
Ø 3,7 x 4,2 cm
12 u.



Nº 1 Ø 2,3 cm
1 u.



Nº 2 Ø 2,5 cm
1 u.



Nº 3 Ø 2,3 cm
1 u.



Nº 4 Ø 2,3 cm
1 u.



Nº 5 Ø 2,5 cm
1 u.



Nº 6 Ø 2,5 cm
1 u.



Nº 7 Ø 2,5 cm
1 u.



Nº 8 Ø 2,5 cm
1 u.



Nº 9 Ø 2,5 cm
1 u.



Nº 10 Ø 2,5 cm
1 u.



Nº 11 Ø 2,5 cm
1 u.



Nº 12 Ø 2,5 cm
1 u.



■ ADAPTADOR PORTABOQUILLAS MEDIANO PLÁSTICO

Plastic piping bag coupler medium
Adaptateur pour douilles moyen en plastique - Adaptador porta-bicos medio de plástico - Aattatore porta beccuccio medio in plastica

510082
Ø 2,5 - 3,1 cm · 2 u.



■ ADAPTADOR PORTABOQUILLAS PEQUEÑO PLÁSTICO

Plastic piping bag coupler small
Adaptateur pour douilles petit en plastique - Adaptador porta-bicos pequeno de plástico - Aattatore porta beccuccio piccolo in plastica

510081
Ø 1,8 cm · 1 u.

BOQUILLAS PLÁSTICO



Plastic nozzles · Douilles en plastique · Bicos de plástico · Beccucci in plastica



■ **RIZADA** - Curled - Frisé - Ondeadó - Arricciato

510019	Ø 0,3 cm	boquilla nº3	6 u.
510020	Ø 0,5 cm	boquilla nº5	6 u.
510021	Ø 0,7 cm	boquilla nº7	6 u.
510022	Ø 0,9 cm	boquilla nº9	6 u.
510023	Ø 1,1 cm	boquilla nº11	6 u.
510024	Ø 1,3 cm	boquilla nº13	6 u.



■ **LISA** - Smooth - Lisse - Liso - Liscio

510009	Ø 0,5 cm	boquilla nº3	6 u.
510010	Ø 0,7 cm	boquilla nº5	6 u.
510011	Ø 0,9 cm	boquilla nº7	6 u.
510012	Ø 1,1 cm	boquilla nº9	6 u.
510013	Ø 1,3 cm	boquilla nº11	6 u.
510014	Ø 1,5 cm	boquilla nº13	6 u.

510200 Ø 0,3/0,5/0,7/0,9/1,1/1,3 cm
 6 u. · Juego 6 boquillas / nozzles set



■ **SURTIDAS** - Assortment - Assortis - Sortidos - Assortiti

510138
A 12 u.

510139
B 12 u.

510201 Ø 0,5/0,7/0,9/1,1/1,3/1,5 cm
 6 u. · Juego 6 boquillas / nozzles set



■ **SURTIDAS + ADAPTADOR ESPECIAL**

Assortment + special adaptors - Assortis + adaptateurs spéciaux - Sortidos + adaptador especial - Assortiti + adattatori speciali

510136

24 u.



535316
 35,5 x 28 x 25 cm

■ **PORTA BOQUILLAS. HASTA 30 BOQUILLAS -**

Piping tips display. Up to 30 piping tips - Porte douilles. Jusqu'à 30 douilles - Porta bicos. Até 30 bicos - Porta beccucci. Fino a 30 beccucci

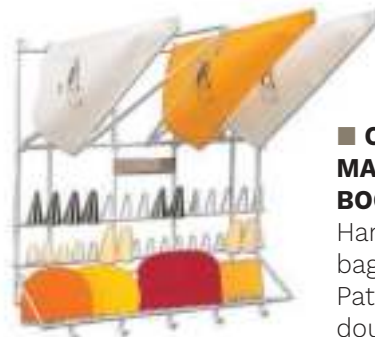

■ **COLGADOR MANGAS Y BOQUILLAS**

Hanger for piping bags and nozzles. Patère poches à douille et tuyaux - Cabide sacos pasteleiros e bicos - Staffa per appendere tasche e beccucci

535244
 50 x 50 cm
 Peso / Weight: 1,3 Kg
 1 u.



UTILLAJE

Tools · Outillage · Utensílios · Utensili



■ **BATIDORES MANGO PP** - Whisk - Fouet - Batedor - Frullatore manico pp

535515	25 cm		1 u.
535010	30 cm		1 u.
535746	35 cm		1 u.
535747	40 cm		1 u.
535745	45 cm		1 u.
535748	50 cm		1 u.

■ **BATIDORES MANGO EXOGLAS** - Whisk - Fouet - Batedor - Frullatore manico

535044	25 cm.		1 u.
535045	30 cm.		1 u.
535046	35 cm.		1 u.
535047	40 cm.		1 u.
535048	45 cm.		1 u.
535049	50 cm.		1 u.



■ **BATIDORES MANGO ACERO INOX.** - Handle. Stainless steel - Fouets manche en acier inox. - Batedores cabo de aço inox. - Frullatori manico acciaio inox.

535199	25 cm		1 u.
535226	35 cm		1 u.
535219	40 cm		1 u.
535224	45 cm		1 u.
535225	60 cm		1 u.



■ **BROCHA DE SILICONA 220°** - Silicone brush 220° - Pinceau silicone 220° - Broxa silicone 220° - Spazzola silicone 220°

535076	(1) Cerda / Bristle: 4 cm		1 u.
535077	(1) Cerda / Bristle: 6 cm		1 u.
535539	(1) Cerda / Bristle: 7,5 cm		1 u.

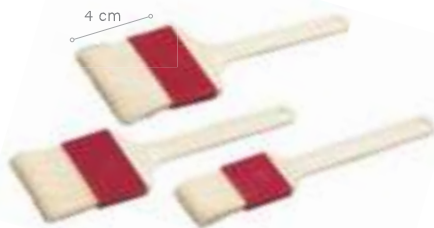

■ **BROCHA CERDA NATURAL** - Brush. Natural bristle - Brosse soie naturelle - Broxa cerda natural - Spazzola setole naturali

535058	Cerda / Bristle: 4 x 4 cm		1 u.
535059	Cerda / Bristle: 4 x 6 cm		1 u.
535060	Cerda / Bristle: 4 x 7,5 cm		1 u.
535742	Cerda / Bristle: 4 x 10 cm		1 u.



■ **BROCHA CERDA NATURAL** - Brush Natural bristle - Brosse soie naturelle - Broxa cerda natural - Spazzola setole naturali

535294	Cerda / Bristle: 6 x 4 cm		1 u.
535315	Cerda / Bristle: 6 x 5 cm		1 u.
535156	Cerda / Bristle: 6 x 7,5 cm		1 u.

RASPADORES



Scraper - Gratoir - Rasgador - Raschiatore



■ **RÍGIDO ACERO INOX.** - Stiff stainless steel - Rigide acier inox. - Rígido aço inox. - Rigido acciaio inox.

541215

11 x 10,5 cm · 1 u.



■ **FLEXIBLE ACERO INOX.** Flexible stainless steel - Flexible acier inox. - Flexível aço inox. - Flessibile acciaio inox.

541308

12 x 11,5 cm · 1 u.



■ **RÍGIDO ACERO INOX.** - Stiff stainless steel - Rigide acier inox. - Rígido aço inox. - Rigido acciaio inox.

541311

19 x 14,5 cm · 1 u.



■ **ACERO INOX.** - Stainless steel - Acier inox. - Aço inox. - Acciaio inox.

541312

24,5 x 15 cm · 1 u.



■ **ESPÁTULA PROFESIONAL CHOCOLATE** - Professional spatula chocolate - Spatule professionnelle chocolat - Espátula profesional chocolate - Spatola professionale cioccolato

541309

15 x 6 cm · 1 u.



■ **ACERO INOX CON AGARRE REDONDEADO**

- Stainless steel dough cutter with round handle - Corne de pâtissier inox avec grip rond - Raschiatore inox. Con impugnatura arrotondato

541001

13 x 11 cm · 1 u.



■ **FLEXIBLE ACERO INOX.** Flexible stainless steel - Flexible acier inox. - Flexível aço inox. - Flessibile acciaio inox.

541197

17,5 x 10 cm · 1 u.



(*)

■ **LISO PLÁSTICO** - Dough in plastic - Lisse en plastique - Liso plástico - liscio plastico

541321

11,3 x 7,5 cm · 1 u.



(*)

■ **LISO PLÁSTICO** - Dough in plastic - Lisse en plastique - Liso plástico - liscio plastico

541314

14,8 x 9,9 cm · 1 u.

* Tolerancia térmica - Heat tolerance - Tolérance thermique - Tolerância térmica - Tolleranza termica: +- 105°



BOLES

Bowls - Bols - Tacas - Ciotole



535032	Ø 17,5 cm · H: 8 cm · 1.000 ml	1 u.
535033	Ø 23 cm · H: 10,5 cm · 2.500 ml	1 u.
535034	Ø 27,5 cm · H: 12 cm · 4.500 ml	1 u.

■ PLÁSTICO ROJO - CON ASA - APILABLE - APTO PARA USO CORTO EN MICROONDAS

Red plastic - With convenient handle stackable - Suited for short-term in microwaves
 Plastique rouge - Avec anses - Empilable - Convient pour une courte utilisation au micro-ondes
 Plástico vermelha - Com pegas - Empilhável - Apto para uma curta utilização em Micro-ondas
 Plastica rossa - Con manici - Impilabile - Adatto per un uso breve ni microonde



■ **SEMIREDONDO PLÁSTICO** - Half round plastic - Semi-rond en plastique - Semi-redonda plástico - Semi rotonda in plastica

	Ø 17,5 cm	H: 8 cm	1.000 ml
	Ø 23 cm	H: 10,5 cm	2.500 ml
536025	Ø 27,5 cm	H: 11,5 cm	4.500 ml
6 u.	Ø 32 cm	H: 15 cm	6.000 ml
	Ø 36 cm	H: 16 cm	9.000 ml
	Ø 40 cm	H: 18 cm	13.000 ml

■ **PLÁSTICO CON PICO Y ASA** - Plastic with spout and handle - Poule plastique - In plastica con beccuccio e maniglia

526000	Ø 23,5 x H: 14 cm · 4.000 ml · 1 u.
---------------	--------------------------------------



■ **METAL** - Metal - Métal - Metal - Metallo

535266	Ø 24 cm · H: 10 cm · 2.500 ml · 1 u.
---------------	---------------------------------------



■ **PLÁSTICO** - Plastic - Plastique - Plástico - Plastica

526140	Ø 17,5 cm · H: 8 cm · 1.000 ml	1 u. A
526141	Ø 27,5 cm · H: 12 cm · 4.500 ml	1 u. B
526142	Ø 36 cm · H: 16 cm · 9.000 ml	1 u. C

UTILLAJE

Tools · Outillage · Utensílios · Utensili



■ **COLADOR TAMIZ EXOGLASS MALLA A. INOX.** - Exoglass sieve strainer - Tamis exoglass maille inox - Colino setaccio maglia In acciaio inox

535218

Ø 20 cm

Paso / abertura: 0,7 mm

 1 u.



■ **CEDAZO PLÁSTICO AZÚCAR GLAS** - Plastic strainer icing sugar - Tamis en plastique sucre glace - Peneira plástico açúcar glass - Setaccio plastica zucchero a velo

535036

Ø 18,5 x 10,5 cm

Paso / abertura: 0,5 mm

Malla / rede: 0,2 mm ·  1 u.



■ **CEDAZO PLÁSTICO** - Plastic strainer - Tamis en plastique - Peneira de plástico - Setaccio plastico

535040

Ø 30,5 x 11 cm

Paso / abertura: 0,85 mm

Malla / rede: 0,24 mm ·  1 u.



■ **CEPILLO HARINERO** - Flour brush - Brosse farinière - Escova farinha - Spazzolino per farina

Blanco - White - Blanc - Branco - Bianco

535064

30 cm ·  1 u.



■ **ESTAMPADOR DE REJILLA** - Cookie stamp crisscross pattern - Grille d'impression - Estampador de grelha - Stampo per decorare a griglia

535271

Ø 3 cm ·  1 u.

■ **PARTIDOR TORTAS** - Cake cutter - Fendeur de galettes - Partidor tortas - Porzionatore torte

535273

Ø 26,5 cm · 12 / 16 piezas. ·  1 u.





CORTAPASTAS

Cookie cutter - Coupe-pâtes - Cortador de massa - Affetta torte

NEW



■ **BUCKET INOX**
543022

Ø 6,6 x H: 3 cm
📦 1 u.

NEW



■ **SLICE INOX**
543054

11,6 x 6 x H: 3 cm
📦 1 u.



■ **MINI ECLAIR INOX**
543236

1,8 x 6 cm
📦 1 u.



■ **ECLAIR INOX**
543235

2,5 x 12,5 cm
📦 1 u.

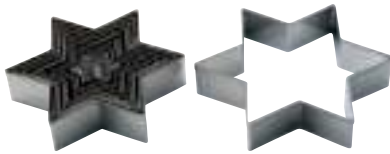

■ **ESTRELLAS INOX.**

Stainless steel stars - Étoiles en inox - Estrelas inox. - Stelle inossidabile

543017

Ø 3,7/5,1/6,6/8,2/9,6/11/12,5/13,7/15 cm
📦 x 9 u.

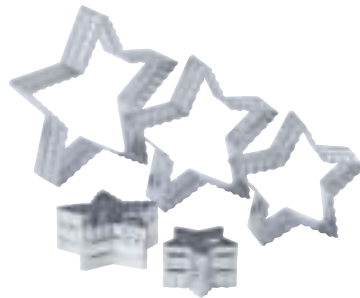

■ **ESTRELLAS INOX.**

Stainless steel stars - Étoiles en inox - Estrelas inox. - Stelle inossidabile

543233

Ø 6/8,5/11/13,5/16 cm x H: 4 cm
📦 x 5 u.



■ **REDONDO INOX.** - Round inox. - Rond inox. - Redondo inox. - Rotondo inox.

541027

Ø 2,5 x 11,5 cm · 📦 12 u.



■ **CORAZÓN ACERO INOX.**

Heart-shaped - Cœur - Coração - Cuore inox

535235

Ø 5 / 6,5 / 8 cm x H: 2 cm
📦 3 u.

NEW



■ **CORAZÓN INOX SURTIDAS** -

Stainless steel heart assorted - Coeur inox assorties - Coração inox sortidas - Cuore inox assortiti

541031

Ø 3.5/4/4.5/5.5/6.5/7.5/8.5 cm x H: 4 cm
📦 x 7 u.



■ **CIRCULAR EXOGLASS®**

- Round - Rond - Circular - Circolare

535139

B Ø 2 a 10 cm
📦 9 u

535138

A Ø 2 a 10 cm
📦 9 u.



CORTAPASTAS



Cookie cutter - Coupe-pâtes - Cortador de massa - Affetta torte

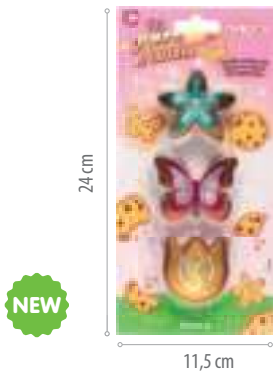

NEW



5,6 x 5,6 cm.



6 x 5 cm.



4,5 x 4,8 cm.

■ **SET FLORES ACERO INOX** - Stainless steel flower set - Ensemble de fleurs acier inox - Conjunto de flores aço inox - Set di fiori acciaio inox.

535344

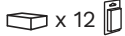

■ **PLÁSTICO** - Plastic - Plastique - Plástico - Plastica

543051

6,9 x 9 cm · 1 u.

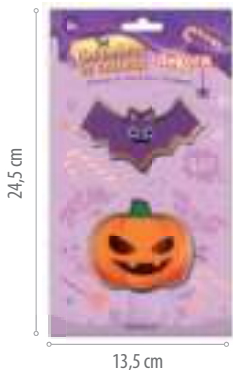

24,5 cm

13,5 cm



7,5 x H: 6,7 cm.



9,3 x H: 5,5 cm.

■ **SET HALLOWEEN ACERO INOX** - Stainless steel halloween set - Ensemble de halloween acier inox - Conjunto de halloween aço inox - Set di halloween acciaio inoxi

535338

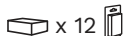

NEW

24 cm

11,5 cm



6,7 x 5,5 cm.

■ **SET DINOSAURIOS ACERO INOX** - Stainless steel dinosaurs set - Ensemble de dinosaures acier inox - Conjunto de dinosauros aço inox - Set di dinosauri acciaio inox

535345

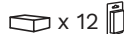

24,5 cm

13,5 cm



6,1 x H: 8,6 cm.



6,4 x H: 8,9 cm.

■ **SET NAVIDAD ACERO INOX** - Stainless steel christmas set - Esemble de Noël acier inox - Conjunto de natal aço inox - Set di natale acciaio inoxi

535337

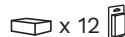



CORTADORES

Cutter - Coupeur



■ **PIZZAS ACERO INOX.** - Stainless steel - Acier inox. - Aço inox. - Acciaio inox.

535352

L: 23 cm x Ø 10 cm ·  1 u.



■ **CROISSANTS ACERO INOX.** - Stainless steel - Acier inox. - Aço inox. - Acciaio inox.

535117

20 x 11 cm ·  1 u.



■ **EXTENSIBLE 5 RUEDAS INOX.**

Extensible, 5 wheels. Stainless - Extensible 5 roues inox. - Extensível 5 rodas inox. - Estensibile 5 ruote inox.

Apto para lavavajillas / Dishwasher proof
Anchura máxima de corte entre ruedas /
Maximum cutting with between wheels: 12,5 cm

535148

 1 u.

■ **PISTOLA DE AZÚCAR** - Sugar gun - Pistolette du sucre - Pistola de açúcar - Rullo speciale legno - Pistola da zucchero

535197

Ø 2 cm x 16,5 cm

 1 u.



CON 20 DISCOS INTERCAMBIABLES

With 20 Interchangeable discs
Avec 20 disques interchangeables
Com 20 discos intercambiáveis
Con 20 dischi intercambiabili

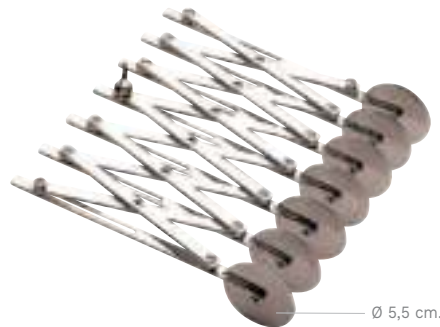

■ **EXTENSIBLE 7 RUEDAS INOX.**

Extensible, 7 wheels. Stainless - Extensible 7 roues inox. - Extensível 7 rodas inox. - Estensibile 7 ruote inox.

Apto para lavavajillas / Dishwasher proof
Anchura máxima de corte entre ruedas /
Maximum cutting with between wheels: 12,5 cm

535149

 1 u.

UTILLAJE

Tools · Outillage · Utensílios · Utensili



■ **CUCHILLA PARA CORTAR PAN** - Blade for cutting bread - Lame pour couper le pain
Folha para cortar pão - Taglierino per pane

535251

15 cm · Cuchilla / Blade: 4 cm ·  1 u.



■ **RODILLOS PUNTEADORES PLÁSTICO** - Plastic pointed rolling pins - Rouleaux pontillieux en plastique - Rolos ponteadores plástico - Rulli puntatori in plastica

535171

Ancho rodillo / Width of the rolling pin: 11,5 cm ·  1 u.



■ **CORTADORES PLÁSTICO CIRCULAR DE REJILLA**
Round plastic cutters with grid - Coupeur en plastique rond avec grillage - Cortadores plástico circular de grade - Cutter plastica circolare a griglia

535306

Ancho rodillo / Width of the rolling pin: 11,5 cm ·  1 u.

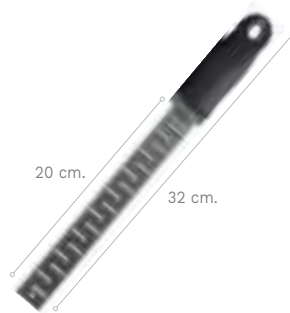

■ **RALLADOR GRANDE ESPECIAL** - Grater - Râpe - Ralador - Grattugia rende speciale

626002

20 x 2,5 cm ·  1 u.

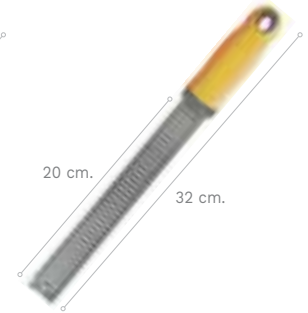

■ **RALLADOR FINO ESPECIAL** - Grater - Râpe - Ralador - Grattugia rende speciale

626000

20 x 2,5 cm ·  1 u.



■ **RODILLO DE PLÁSTICO** - Plastic rolling pin - Rouleau en plastique - Rolo de plástico - Rullo in plastica

535194

Rodillo / rolling pin: Ø 8 x 40 cm
Largo total / Total length: 62 cm ·  1 u.



■ **RODILLO FIJO MADERA** - Wooden rolling pin - Rouleau en bois - Rolo de madeira - Rullo fisso legno

535000

Rodillo / rolling pin: Ø 8 x 50 cm
Largo total / Total length: 70 cm ·  1 u.



■ **RODILLO ESPECIAL MADERA** - Special wooden rolling pin - Rouleau spècial en bois - Rolo especial madeira

535410

Rodillo / rolling pin: Ø 8 x 50 cm
Largo total / Total length: 80 cm ·  1 u.



ESPÁTULAS

Palettes - Spatule - Spatola



■ **ACERO INOX. PLANA** - Stainless steel flat - Plate en acier inox - Plana de aço inox - Acciaio inox. Piana

541052

(1): 34 cm

(2): 21 cm

Ancho / Widht:
3,4 cm

1 u.

541053

(1): 39 cm

(2): 26 cm

Ancho / Widht:
3,4 cm

1 u.

541054

(1): 44 cm

(2): 31 cm

Ancho / Widht:
3,4 cm

1 u.

541055

(1): 49 cm

(2): 36 cm

Ancho / Widht:
3,4 cm

1 u.

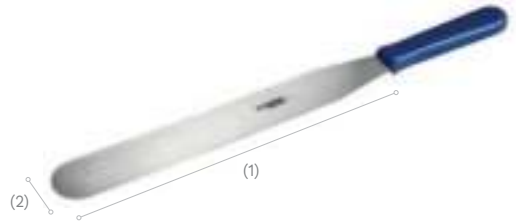

■ **ACERO INOX. PLANA** - Stainless steel flat - Plate en acier inox - Plana de aço inox - Acciaio inox. Piana.

541010 (1): 30 cm · (2): 4,5 cm 1 u.

541011 (1): 35 cm · (2): 5 cm 1 u.

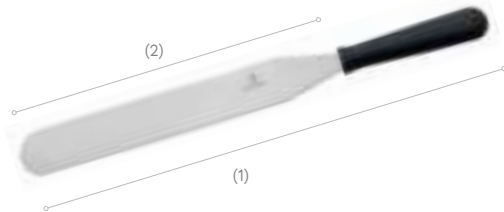

■ **FLEXIBLE A. INOX** - Flexibel stainless - Flexible inox - Flexível inox. - Flessibile inox.

541026 (1): 24 cm · (2): 12 cm 1 u.

541019 (1): 35 cm · (2): 24 cm 1 u.



■ **ANGULAR ESPECIAL PIZZA/PAN A. INOX** - Pizza/pan flippers angular stainless - Angulaire spécial pizza/pain inox - Pizza especial/pão em angular a. Inox - Speciale per pizza/pane inox. angolare

541048

17 x 8 cm · 1 u.



■ **ACERO INOX. ANGULAR** - Angular - Acier inox angulaire - Aço inox. angular - Acciaio inox. angolare

541106 (1) 10 x (2) 3,4 cm 1 u.

541228 (1) 15 x (2) 3,4 cm 1 u.

541008 (1) 20 x (2) 3,4 cm 1 u.

541230 (1) 25 x (2) 3,4 cm 1 u.

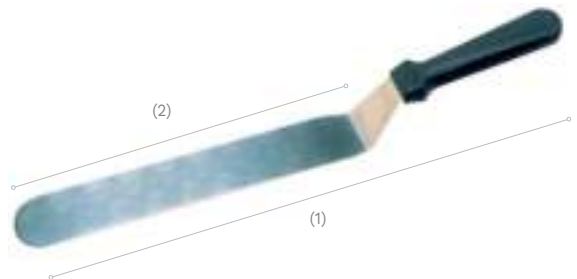

■ **ACERO INOX. ANGULAR** - Angular - Acier inox angulaire - Aço inox. angular - Acciaio inox. angolare

541194

(1): 32,5 cm - (2): 17 cm

Ancho / Width: 3 cm · 1 u.

ESPÁTULAS

Palettes - Spatule - Spatola



■ ANGULAR PUNTIAGUDA A.

INOX - Blade pointedly - Lame pointue - Lama appuntita - Lâmina de forma incisiva

541012

9 cm · Ancho hoja 2 cm

1 u.

■ ANGULAR REDONDA A.

INOX. Round blade - Lame ronde - Lama rotonda - Lâmina redonda

541013

9 cm · Ancho hoja 2 cm

1 u.

■ ANGULAR HOJA ONDULADA

A. INOX - Wave - blunt; Vague-émoussée; Onda - smussata; Onda - sem corte

541014

15 cm · 1 u.

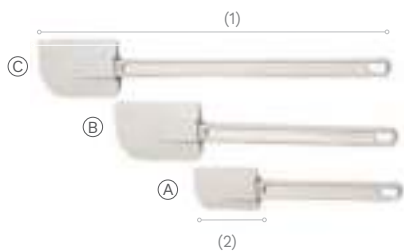

■ **PLÁSTICO - GOMA** - Plastic-rubber - Plastique gomme - Plástico-goma - Plastica-gomma

541028 **A** (1): 25 cm (2): 8 x 5 cm 1 u.

541029 **B** (1): 35 cm (2): 11,5 x 7 cm 1 u.

541030 **C** (1): 45 cm (2): 11,5 x 7 cm 1 u.



■ EXOGLASS®

541017 25 cm 1 u.

541020 30 cm 1 u.

541021 35 cm 1 u.

541024 50 cm 1 u.

Mango de fibra reforzada
Incluye agujero para colgar



■ **SILICONA SUPER RESISTENTE 230°** - Silicone Super Resistant 230° - Silicone Super Résistant 230° - Resistente Até 230° - Silicone Super Resistente Fino A 230°

541245 (1): 25 cm 1 u.

541007 (1): 35 cm 1 u.

541246 (1): 45 cm 1 u.

■ **SILICONA** - Silicone

541113 25 cm 1 u.





CUCHILLOS

Knives - Couteaux - Facas - Coltelli

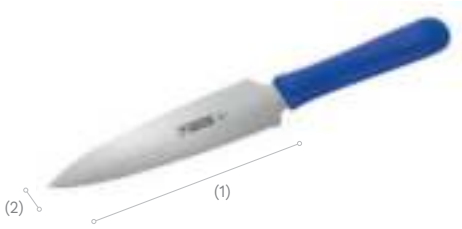

■ PUNTA DOBLE HOJA SIERRA/LISA

Pointed double sided - Point double lame
- Serra dupla/ponta de lâmina lisa - Doppia
punta seghettato/liscio

541016

(1): 16 cm · (2): 4,8 cm

1 u.

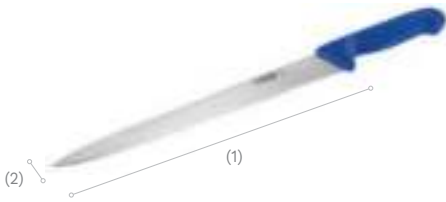

■ **LISO PARA PASTELERÍA** - Cake and pastry
plain - Lame lisse pâtisserie - Faca lisa para
pasteleria - Liscio per pasticceria

541003

(1): 31 cm · (2): 3,4 cm

1 u.

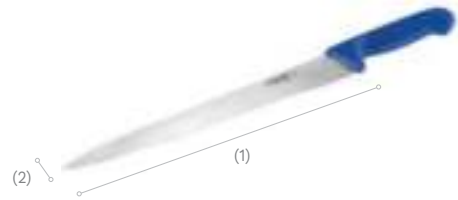

■ **SIERRA PARA PASTELERÍA** - Cake and
pastry saw - Denté pour pâtisserie - Faca
serra para pasteleria - Seghettato per
pasticceria

541009

(1): 31 cm · (2): 3,4 cm

1 u.



■ **DOBLE HOJA SIERRA LISA** - Baker's knife
double sided - Couted double dentelé inox. -
Faca de dupla serra inox. - Coltello a doppia
seghettatura inox

541340

(1): 36 cm (2): 3,4 cm · 1 u.



■ **SIERRA ONDULADO INOX.** - Bread knife
- À pain - Para pão - Con lama seghettata a
onde inox.

541098

(1): 24 cm (2): 2,6 cm · 1 u.



■ **SIERRA INOX.** - Serrated knife - Dentelé
inox. - Serra inox. - Chiuso inox

541079

(1): 44,5 cm · (2): 31 cm (3): 3,4 cm · 1 u.

541085

(1): 49,5 cm (2): 36 cm (3): 3,4 cm · 1 u.



■ **LISO** - Smooth - lisse - lisa - liscio

541105

(1): 24 cm · (2): 2,6 cm

1 u.



■ **SIERRA** - Bread scoring - Dentelé - De serra - Chiuso

541190

(1): 8,7 cm (2): 1,5 cm · 1 u.



■ **PUNTILLA** - Paring - Pointu - De ponta Punta

541108

(1): 9 cm · (2): 20 cm · 1 u.



■ **NIVELADOR ACERO INOX.** - Stainless steel leveler - Nivelador de aço inoxidável - Niveleur en acier inoxydable - Livellatore in acciaio inox

535530

50 x 18 x h: 6 cm. · 1 u.

Ancho max. de esparcimiento: 40 cm. / Grosor: 0,1 a 1,8 cm.

Max width spread: 40 cm. / Thickness: 0.1 to 1.8 cm

Largueur maximale largeur : 40 cm. / Épaisseur : 0,1 à 1,8 cm.

Largura máxima propagação: 40 cm. / Espessura: 0,1 a 1,8 cm.

Larghezza massima diffusione: 40 cm. / Spessore: da 0,1 a 1,8 cm.



■ **SERRADO PARA TARTAS** - Serrated for cakes - Dentelé pour des tapes - Serrada para tapas - Chiuso per torte

541350

45,5 cm · Peso / Weight: 350 g · 1 u.

Acero inox. · Con 3 hojas de sierra · Ajustable desde 1 a 9 cm

With 3 saw leaves. Adjustable from 1 to 9 cm

Avec 3 feuilles de scie. Ajustable de 1 à 9 cm

Com 3 folhas de serra. Ajustável de 1 a 9cm

Con sega a 3 fogli. Regolabile da 1 a 9 cm



■ **PALA ELÉCTRICA DE QUEMAR INOX. 220 V.**

Electric burner. Stainless 220 v. - Palle électrique de brûler inox. 220 V. - Pala eléctrica de queimar inox. 220v. - Paletta elettrica per scottare inox. 220v

535252

1.500 W. · 7 x 23 cm · Peso / Weight: 1,2 Kg · 1 u.

Bajo pedido / On request / Sur demande / A pedido / Su richiesta

■ **SOPLETE PROFESIONAL** -

Professional blowtorch -Chalumeau professionnel - Maçarico profissional - Cannello professionale

535155

15,5 x 7,5 x H: 3,5 cm · Peso / Weight: 250 g · 1 u.



VENTAJAS DEL PRODUCTO: Seguro, ligero - Fácil de recargar - Portátil (sin cables) - Llama regulable - Sistema de seguridad - Temperatura máxima: 1.300°

EN: ADVANTAGES OF THE PRODUCT - Safe, light - Easy to reload - Portable (no cables) - Adjustable flame - Security system - Maximum temperature: 1300° -

FR: AVANTAGES DU PRODUIT - Sûr, léger - Facile à recharger - Portable (sans câbles) - Flamme réglable - Système de sécurité - Température maximale: 1.300° -

PT: VANTAGENS DO PRODUTO - Seguro, leve - Fácil de recarregar - Portátil (sem cabos) - Chama ajustável - Sistema de segurança - Temperatura máxima: 1.300° - **IT:** VANTAGGI DEL PRODOTTO - Sicuro, leggero - Ricarica facile - Portatile (non ha cavi) - Fiamma regolabile - Sistema di sicurezza - Temperatura massima: 1.300°



UTILLAJE

Tools · Outillage · Utensílios · Utensili



■ **ROLLOS DE ACETATO** - Acetate rolls -
Rouleau en acétate - Rolos de acetato -
Rotoli di acetato

535329

75 µ · 4 cm, x 305 mts. ·  1 u.



■ **ROLLOS DE ACETATO** - Acetate rolls
- Rouleau en acétate - Rolos de acetato
- Rotoli di acetato

535233 200 µ. 3 cm x 50 mts.  1 u.

535234 200 µ. 3,5 cm x 50 mts.  1 u.

535236 200 µ. 4 cm x 50 mts.  1 u.

535238 200 µ. 4,5 cm x 50 mts.  1 u.

535237 200 µ. 5 cm x 50 mts.  1 u.

PASO A PASO

Step by step - Pas à pas - Passo a passo - Passo dropo passo

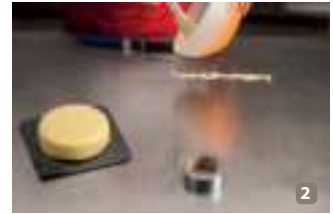



■ **LÁMINAS DE ACETATO** - Acetate sheets
 - Lames en acétate - Lâminas de acetato
 - Lamine di acetato

535331

75 µ · 60 x 40 cm ·  50 u.



■ **HOJAS PLÁSTICO TRANSPARENTE** - Transparent plastic sheets
 - Lames en plastique transparent
 - Folhas plástico transparente - Fogli di plastica trasparente

506003

110 µ · 60 x 40 cm ·  100 u.



■ **FUNDAS DE PLÁSTICO PARA CARROS** -

Plastic covers for carts - Étui en plastique pour charriots - Estojos de plástico para carroças - Fodere in plastica per carri

506001

12 µ · 60 x 40
 75 x 25 x 180 cm
 200 u.

506007

12 µ · GN 2/1
 74 x 35,5 x 180 cm
 200 u.



■ **FUNDAS PLÁSTICO PARA BANDEJA**

- Plastic tray covers - Couvre-plateaux en plastique - Tampas de plástico para tabuleiros - Coprivassoio in plastica

506002

40 µ · 80 x 55 cm ·  100 u.



TERMÓMETROS

Thermometers - Thermomètres - Termómetro - Termometro

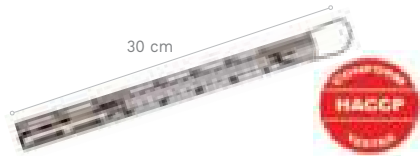

■ **CARAMELO MALLA METAL ALCOHOL 80° ~ +200°** - Caramel metal mesh. Alcohol. - Caramel maille alcool. - Caramelo malha metal álcool. - Per caramello maglia metallo alcool

537017

1 u.



■ **DIGITAL MULTIFUNCIÓN -40° ~ +200°** - Digital with inox probe - Numérique avec sonde inox - Digital com sonda de aço inox - Digitale con sonda in acciaio inox

537016

21.8 x 2.4 x 1.9 cm · 1 u.



■ **DIGITAL MULTIFUNCIÓN -50° ~ +150°** - Digital with inox probe - Numérique avec sonde inox - Digital com sonda de aço inox - Digitale con sonda in acciaio inox

537013

Mide temperatura en °C /
Measures temperature in °C
Effettua le misurazioni in °C

20 x 2 x 2 cm

1 u.



■ **ELECTRÓNICO CON Sonda -50° ~ +300°** - Electronic with probe - Électronique avec sonde - Eletrônico com sonda - Digitale con sonda

537009

Waterproof alarma
10.5 x 7.5 x 2 cm
Longitud Sonda : 21 cm

1 u.



■ **RELOJ DIGITAL CON ALARMA 24 H.** - Electronic timer clock with alarm 24h - Horloge digital avec alarme 24h - Relógio digital com alarme - Orologio digitale con timer

537008

6,6 x 5,3 x 1,2 cm · 1 u.



■ **INFRARROJOS -50 ~ 420 ° C**
Infrared - Infrarouge -
Infravermelh - A infrarossi

537000

21.5 x 15.5 x 5 cm · 1 u.



■ **INFRARROJOS -35° ~ 365° C**
Infrared - Infrarouge -
Infravermelh - A infrarossi

537004

17.5 x 8.5 x 4cm · 1 u.



■ **PH METRO DE 0 A 14 IP 57**

Calibración automática del PH 7

EN: Automatic PH 7 calibration system

FR: Calibrage automatique du PH 7 - PT:

Calibração automática do PH 7 - IT:

Calibrazione automatica del PH 7

535346

3,1 x 8 cm · 1 u.



■ **PALAS DE MEDICIÓN DE PLÁSTICO** - Plastic
- Plastique - Plástico - Palette con misurino in
plastica

535025
500 ml
📦 6 u.

535026
1.000 ml
📦 6 u.

535029
1.250 ml
📦 6 u.



■ **PALAS DE MEDICIÓN DE PLÁSTICO (PP)** - Plastic
- Plastique - Plástico - Palette con misurino in
plastica

535321
250 ml
📦 6 u.



■ **JARRA MEDIDORA DE CRISTAL** - Glass measuring
cup - Pichet gradué en verre
- Jarro medição - Caraffa con
misurino in vetro

535055
1 litro · 📦 1 u.



■ **JARRA DE MEDICIÓN DE PLÁSTICO** - Meter jar
- Carafe mesurante - Jarra
medidora - Caraffa con
misurino in plastica

535003 1 litro. 📦 6 u.

535004 2 litros. 📦 6 u.

535005 3 litros. 📦 6 u.

535006 5 litros. 📦 6 u.

■ **BOTELLA DE PLÁSTICO PARA BAÑAR BIZCOCHO CON ESCALA GRADUADA** - Plastic
ottle to dip sponge cake with graduated scale
- Bouteille en plastique pour bagner gâteaux
avec échelle graduée - Garrafa de plástico para
panha com escala graduada - Borraccia in plas-
tica per inzuppare il biscotto con scala graduata

ERGONÓMICA - Ergonomic - Ergonomique
Ergonómico - Ergonomica

535198
10,5 x 6 x H: 27,5 cm · 1 litro.
📦 1 u.



■ **BIBERÓN BOCA ANCHA**
- Dispenser wide nozzle -
Dosificateur bouche large
- Dosificadores bocal largo -
Biberon bocca larga

535330
236 ml
📦 1 u.

535350
354 ml
📦 1 u.

535351
708 ml
📦 1 u.



UTILLAJE

Tools · Outillage · Utensílios · Utensili

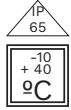

■ **BALANZA ELECTRÓNICA 6 K** - Electronic weighing scale - Balance électronique - Bilancia elettronica

Bandeja acero inox. extraíble. Gran visualización con diodos rojos. Equipado con una segunda pantalla trasera ideal para escuelas. 220V 50/60 Hz y batería recargable 6V. Autonomía: 70 h. - EN: Removable stainless steel tray. Great visibility with red diodes. Equipped with a second rear display, ideal for schools. 220V 50/60 Hz and 6V rechargeable battery. Autonomy: 70 hours.

535105

21 x 17,5 x H: 16 cm · 1 u.

Bajo pedido / On request / Sur demande / A pedido / Su richiesta



■ **BALANZA DIGITAL CAP. 15 Kg / 1g** - Digital scale - Balance numérique - Balanço digital - Bilancia digitale

Pantalla LED de alta definición. Potencia: 4x 1.5V pilas AA (incluido) - EN: High-definition LED Display/Power: 4x 1.5V AA batteries (included) - FR: Affichage LED haute Définition/ Puissance: 4x piles AA 1.5V (inclus) - PT: Display LED de alta definição/Potência: 4 pilhas AA de 1,5V (incluído) - IT: Schermo LED ad alta definizione/Alimentazione: 4x batterie AA da 1,5 V (includere)

535297

37,5 x 30,5 x 4,5 cm · 1 u.

NEW



■ **SIFÓN CREMA** - Siphon for cream. Stainless - Siphon pour crème inox. - Sifão para creme inox - Sifone per crema inox

535343

10 u.



■ **CARTUCHO PARA SIFÓN CREMA** - Cartridges for siphon - Cartouches pour siphon - Cartuchos para sifão - Cartucce per sifone

535341

1 L. · 1 u.



NEW

535363

Base con ruedas para carro 40 l. Medidas: 48 x 37 x 13 cm. Cap. 100 kg. - EN: 40 litre trolley base with wheels - FR: Base de chariot de 40 litres avec roues - PT: Base do carrinho de 40 litros com rodas - IT: Base trolley da 40 litri con ruote

A 1 u.

535359

Tapa plástico blanca - EN: White plastic cover - FR: Couvercle en plastique blanc - PT: Tampa de plástico branca - IT: Copertura in plastica bianca

B 1 u.

535356

Tapa plástico roja - EN: Red plastic cap - FR: Capuchon en plastique rouge - PT: Tampa de plástico vermelha - IT: Tappo di plastica rosso

C 1 u.

535349

Tapa plástico azul - EN: Blue plastic cover - FR: Couvercle en plastique bleu - PT: Tampa de plástico azul - IT: Copertura in plastica blu

D 1 u.

535348

Contenedor para ingredientes Vol.L/KG – 40/25. Medidas: 42,5 x 61 cm. - EN: Container for ingredients - FR: Récipient pour les ingrédients - PT: Contentor para ingredientes - IT: Contenitore per ingredienti

E 1 u.

NEW

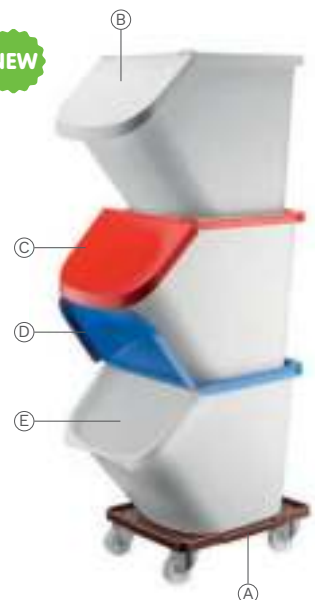

GUANTES



Gloves - Gants - Luvas - Guanti



■ **LATEX**
535186

☞ 1 par.

Temp. MAX
60 °C



■ **CORTOS DE ALGODÓN** - Short cotton - Courts en coton - Curtos de algodão - Corti in cotone

535180

26 x 14,5 cm · ☞ 1 par.

Temp. MAX
220 °C

250 - 280 °C



180 - 200 °C

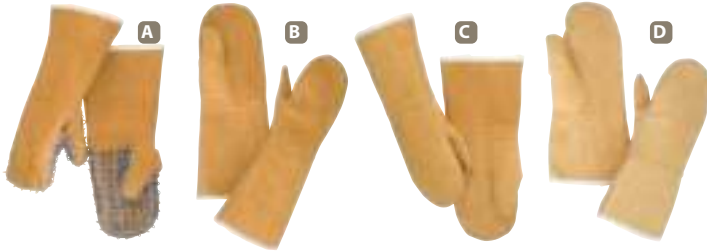

■ **MANOPLAS ANTICALOR PIEL** - Mitts against heat. Leather - Moufles antichaleur peau - Luvas anticalor pele - Manopole contro il calore pelle

535174 Anilla larga / Long ring 40 cm ☞ 1 par **A**

535175 Reforzada larga / Long. Reinforced 40 cm ☞ 1 par **B**

535176 Reforzada mediana / Middle. Reinforced 36 cm ☞ 1 par **C**

535177 Reforzada corta / Short. Reinforced 33 cm ☞ 1 par **D**



Temp. MAX
220 °C

■ **LARGOS DE ALGODÓN** - Long cotton - Longs en coton - Largos de algodão - Lunghi in cotone

535181

40 x 15 cm · ☞ 1 par.



Temp. MAX
+- 250 °C

■ **EN CUERO FORRADO RESISTENTES AL CALOR EXTREMO** - Lined leather in extreme heat resistant - Courts en coton pour le four - De couro forrado em extreme resistente ao calor - In cuoio imbottito resistenti alle temperature estreme

535557

45 x 14 cm · ☞ 1 par.



Temp. MAX
+- 250 °C

■ **DE ALGODÓN RESISTENTES A ALTAS TEMPERATURAS** - Cotton resistant to high temperatures - Coton résistant aux hautes températures - De algodão resistentes a altas temperaturas - In cotone resistenti alle alte temperature

535347

32 x 15 cm · ☞ 1 par.



■ **AGARRADERA DE ALGODÓN** - Cotton grip - Poignée en coton - Asa de algodão - Presina in cotone

535182

29 x 24 cm · ☞ 1 u.

Temp. MAX
220 °C



Temp. MAX
220 °C

■ **AGARRADERA CON BANDA ELÁSTICA** - Cotton even cloth elastic band - Coton élastique band - Luvas largos de algodão elástico band - Presina con banda elastica

535227

29 x 24 cm · ☞ 1 u.



UTILLAJE

Tools · Outillage · Utensílios · Utensili



■ **PORTAPRECIOS PLÁSTICO** - Plastic price tag holders - Porte-prix en plastique - Porta-preços plástico - Espositore porta prezzi plastica

540197

7 x 4 cm ·  15 u.



■ **PORTAPRECIOS PLÁSTICO** - Plastic price tag holders - Porte-prix en plastique - Porta-preços plástico - Espositore porta prezzi plastica

540198

6 x 8 cm ·  25 u.



■ **PORTAPRECIOS CUADRADOS** - Plastic square price tag holder - Porte-prix en plastique carré - Portapreços plástico square - Espositori porta prezzi quadrati

540295

6 x 8 cm ·  40 u.



■ **PORTAPRECIOS PLÁSTICO** - Plastic price tag holders - Holdersporte-prix en plastique - Porta-preços plástico - Espositore porta prezzi plastica

540201

6 x 5 cm ·  50 u.



■ **PALITOS DE PIRULETA** - Lollipop sticks - Bâtonnets pour sucettes - Palitos de chupas - Stecchi per lecca-lecca

515434

 x 12  x 24 u. 



PIPETAS CUENTA GOTAS



Drop-counting pipettes · Pipettes à comptage de gouttes
Pipetas conta-gotas · Pipette conta gocce

Perfectas para dar un toque de sabor, salsa o licor a tus elaboraciones.

EN: To add a touch of a particular flavour to a bottle of sauce, liqueur, vinaigrette, coulis, etc.

FR: Pour ajouter une touche d'une saveur particulière à une bouteille de sauce, liqueur, vinaigrette, coulis, etc.

PT: Para um toque de um sabor específico a um frasco de molho, licor, vinagrete, puré de frutas, etc.

IT: Pipette contagocce. Perfette per aggiungere un tocco di sapore, salsa o liquore alle tue preparazioni.



535314

4 ml / 15 x 0,25 cm

 500 u.



535110

3,5 ml / 8,5 x Ø 1,3 cm

 500 u.





VASITOS DE PLÁSTICO

Little plastic glass · Petit verre plastique · Copinho plástico
Bicchierino plastica



■ SLICE
515001

13,5 x 6,9 x H: 4,2 cm · 160 ml
📦 100 u.



NEW



■ TAPA PARA SLICE
515018

13,6 x 7,1 x H: 0,5 cm
📦 100 u.



NEW



■ ECLAIR XL
515019

14,4 x 4,3 x H: 4,8 cm · 165 ml
📦 100 u.



NEW



■ TAPA PARA ECLAIR XL
515064

14,5 x 4,36 x H: 0,54 cm
📦 100 u.



NEW



■ TRIANGULAR
515075

Ø 8,5 x 6,5 cm · 175 ml
📦 100 u.



■ WAVE
515449

8,5 x 6 x H: 7 cm · 120 ml
📦 100 u.



■ WAFFLE
515452

6,4 x 6,2 x H: 5,9 cm · 70 ml
📦 100 u.



■ PENTA
515468

Ø 7,2 x H: 5,6 cm · 120 ml
📦 100 u.



■ JAPAN
515471

Ø 5 x H: 5,4 cm · 87 ml
📦 100 u.



■ SOFTICE
515453

Ø 5,9 x 7 cm · 105 ml
📦 100 u.



■ SQUARE
515469

5,5 x 5,5 X H: 8 cm · 175 ml
📦 100 u.



■ SQUARE
515073

5 x 7 cm · 120 ml
📦 100 u.



■ WITH BASE
515074

Ø 7 x 6,7 cm · 135 ml
📦 100 u.



Material reciclable al 100% - 100% recy-
cable material - Matériau 100% recycla-
ble - Material 100% reciclável - Materiale
riciclabile al 100%



VASITOS DE PLÁSTICO



Little plastic glass · Petit verre plastique · Copinho plástico
Bicchierino plastica

■ ROUND

515436

Ø 7,8 x 5,7 cm · 210 ml

100 u.



NEW



■ LID FOR ROUND

515481

Ø 8 x 7,5 cm

100 u.



NEW



■ ECLAIR

515482

13,7 x 3,7 x H: 4,1 cm

120 ml

100 u.



NEW



■ LID FOR ECLAIR

515494

14,5 x 4,3 x H: 5,4 cm

100 u.



NEW



515007 7,3 x 8,1 x H: 6,7 cm · 140 ml 100 u.

515451 6,3 x 6,9 x H: 5,7 cm · 85 ml 100 u.



■ GREEK

515450

7,3 x 6,1 cm · 120 ml

100 u.



■ TUBE

515041

Ø 4 x H: 8,5 cm · 80 ml

100 u.



■ CLASSIC

515467

Ø 4,2 x H: 6,5 cm · 65 ml

100 u.



■ HEART

515470

7,3 x 6,4 X H: 5,2 cm · 100 ml

100 u.



Tolerancia térmica - Heat tolerance - Tolérance thermique - Tolerância térmica - Tolleranza termica: -18°C + 70°C / **Libre de BPA** - BPA free - Sans bisphénol - Sem bisfenol - Privo di Bisfenolo · **Lavable en lavavajillas hasta 50 veces** - Washing Machine Safe: up to 50 washes - Lavable au lave-vaisselle : jusqu'à 50 lavages - Lavável na máquina de lavar loiça: até 50 lavagens - Lavabile fino a 50 volte in lavastoviglie.



UTILLAJE

Tools · Outillage · Utensílios · Utensili

■ **PINZAS DEL CHEF EN ACERO INOX.** - Stainless steel Chef's tweezers - Pincettes de chef en acier inoxydable - Pinças do cozinheiro chefe em aço inoxidável - Pinze da chef in acciaio inox.



535300
14,5 x 1 cm



535305
15 x 0,7 cm

■ TUTORIAL RECETA PARA VASITOS

EN: Recipe for cups. FR: Recette de verrines. PT: Receita para copinhos. IT: Tutorial ricetta per bicchierini

Escanea este código QR y sigue los sencillos pasos de este vídeo.

EN: Scan this QR code and follow the simple steps in this video.

FR: Scannez ce code QR et suivez les étapes de cette vidéo.

PT: Digitalize este código QR e siga os passos simples deste vídeo.

IT: Scansiona il codice QR e segui i semplici passaggi illustrati nel video



■ **REJILLA CROMADA** - Chrome-plated grill - Grillage chromage - Grade cromado

540150
60 x 40 cm ·  1 u.



■ **REJILLA CROMADA CON PIES** - Chrome-plated grill with legs - Grillage chromage avec pieds - Grade cromado com pés - Grata cromata con piedini

540235
60 x 40 cm ·  1 u.



540103

Bandeja + tapa / Tray + cover
60 x 40 x H: 6,2 cm

1 u.

540218

Solo tapa / Only cover
59 x 39 x H: 6 cm

1 u.

■ **CUBIERTA TRANSPARENTE PARA BANDEJA DE PLÁSTICO 60 X 40 CM**

PLÁSTICO RESISTENTE A LA CONGELACIÓN - Transparent cover for plastic tray 60 x 40 cm freeze-resistant plastic - Couverture transparent pour plateau en plastique 60 x 40 cm. Plastique résistant à la congélation - Coberta transparente para bandeja de plástico 60 x 40 cm. Plástico resistente à congelação - Copertura trasparente per vassoio in plastica 60 x 40 cm. Plastica resistente al congelamento

■ **BANDEJA ALUMINIO**

Tray aluminium - Plateaux en aluminium - Tabuleiro alumínio - Vassoio alluminio



NEW

540160 60 x 40 x H: 2 cm

Grosor thickness 1 u.
1,5 mm



NEW

540207 60 x 40 x H: 2 cm

Grosor thickness 1 u.
0,8 mm



NEW

540174

60 x 40 x H: 2 cm
Perforada
Perforated
Perforé
Perfurado
Perforato Ø 2 mm

Grosor thickness 1 u.
1,5 mm



540278

60 x 40 cm
Perforada
Perforated
Perforé
Perfurado
Perforato Ø 3 mm

Grosor thickness 1 u.
2 mm



BANDEJAS

Iray · Plateaux · Vasscio



■ STELLA

EXT (A)

540169 Ø 27,5 cm - Color cristal  94 u.

540336 Ø 36,5 cm - Color cristal  36 u.

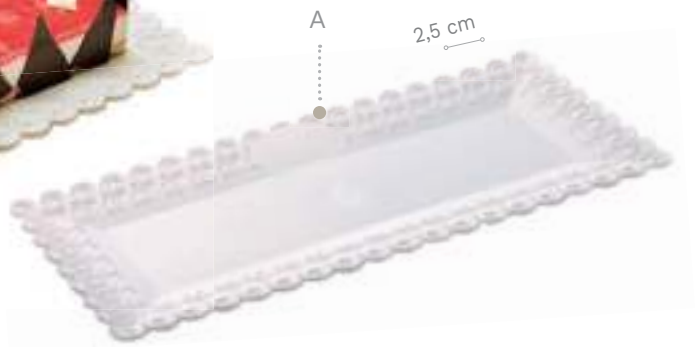

■ RECTANGULAR BLANCA VECCHIO -

Rectangular vecchio - Rectangulaire vecchio -
Rettangolare bianco

EXT (A)

515461 30 x 17 cm  94 u.

A EXTERIOR
B INTERIOR



■ **RECTANGULAR** - Rectangular -
Rectangulaire - Rectangular - Rettangolare

EXT (A)

INT (B)

515421 30 x 15 cm 17,5 x 12 cm  150 u.

515422 35 x 15 cm 32 x 12 cm  150 u.

BANDEJAS

Iray · Plateaux · Vasscio

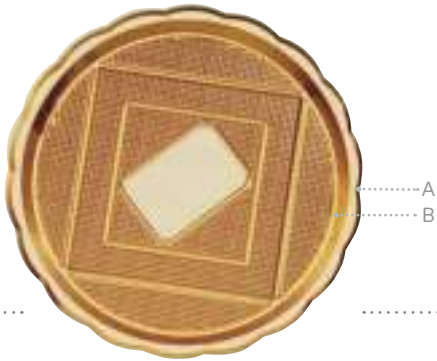

■ MEDORO NEW

	EXT (A)	INT (B)	
540260	Ø 22 cm	Ø 17 cm	125 u.
540264	Ø 30 cm	Ø 25 cm	100 u.
540266	Ø 34 cm	Ø 29 cm	60 u.

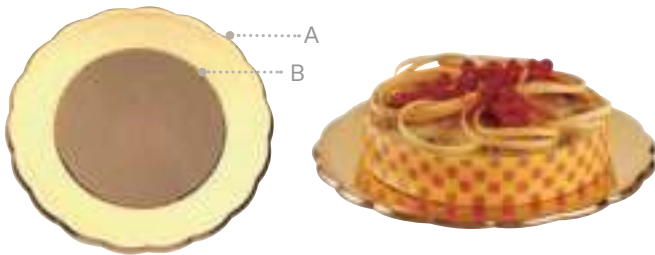

■ MEDORO

	EXT (A)	INT (B)	
540013	Ø 26 cm	Ø 16 cm	120 u.
540014	Ø 28 cm	Ø 18 cm	100 u.
540015	Ø 30 cm	Ø 20 cm	100 u.
540016	Ø 32 cm	Ø 22 cm	100 u.
540017	Ø 34 cm	Ø 24 cm	60 u.
540018	Ø 36 cm	Ø 26 cm	60 u.
540019	Ø 38 cm	Ø 28 cm	60 u.
540009	Ø 42 cm	Ø 32 cm	40 u.



■ TAPA PARA BANDEJA MEDORO ESTÁNDAR -

Lid for standard medoro tray - Couvercle pour plateau medoro standard - Tampa para tabuleiro medoro standard - Coperchio per vassoio medoro standard

540224	34 x 8 cm	60 u.
---------------	-----------	-------



■ RECTANGULAR "MEDORO" - Rectangular - Rectangulaire - Rectangular - Rettangolare

	EXT (A)	INT (B)	
540021	15 x 25 cm	12 x 22 cm	150 u.
540022	15 x 30 cm	12 x 27 cm	150 u.
540023	15 x 35 cm	12 x 32 cm	100 u.
540024	15 x 40 cm	12 x 37 cm	100 u.

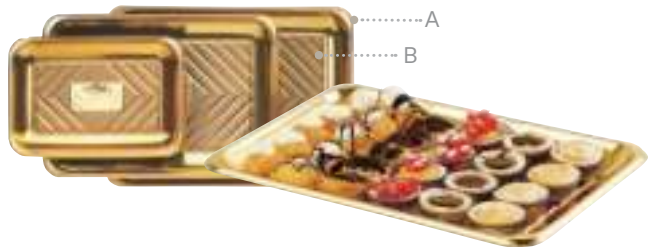

■ "KADO" DORADA - Golden "kado" - "Kado" doré - "Kado" dourada - "Kado" dorato

	EXT (A)	INT (B)	
540253	29 x 21 cm	22,5 x 14,5 cm	200 u.
540254	32 x 22 cm	25 x 15,5 cm	150 u.
540255	34,5 x 25 cm	28 x 18,5 cm	100 u.
540256	37,5 x 28 cm	30,5 x 21 cm	100 u.
540259	37 x 51 cm	30 x 44 cm	100 u.



MINI BANDEJAS PLÁSTICO

Mini plastic tray · Mini plateau en plastique · Mini bandeja de plástico
Mini vasscio in plastica



A



■ **GOGO CUADRADA** - Black square -
Noir carré gogo - Preto quadrado - Nera
quadrato

EXT (A)

515485 9 X 10,5 cm  400 u.

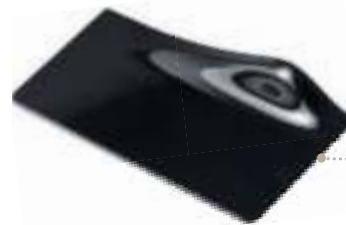

A

■ **GOGO RECTANGULAR** - Black rectangular
- Noir rectangulaire - Preto rectangular -
Nera rettangolare

EXT (A)

515486 14 x 5,8 cm  400 u.



A



■ **GOGO REDONDA 8,5 CM** - Black round -
Noir rond - Preto redondo - Nera

EXT (A)

515484 Ø 8,5 cm  400 u.

BANDEJA EFECTO PIEDRA



Stone effect tray · Plateau effet pierre · Bandeja efeito pedra
Vasscio effeto pedra



■ **COLOR GRIS** - Gray color - Grise - Cor gris
- Colore grigio

540027
24 x 24 cm
 80 u.

■ **COLOR GRIS** - Gray color - Grise
- Cor gris - Colore grigio

540000
11 x 11 cm
 320 u.



■ **COLOR GRIS** - Gray color - Grise - Cor gris
- Colore grigio

540028
30 x 14 cm ·  80 u.



BANDEJAS DE CARTÓN ORO/NEGRO

Cardboard plate gold- black · Assiette carton or-noir · Prato cartão oro-
preto · Piatto in cartone oro- nero



540053 Ø 20 cm  100 u.

540208 Ø 24 cm  100 u.

540185 Ø 26 cm  100 u.

540209 Ø 28 cm  100 u.

540212 Ø 30 cm  100 u.

540192 Ø 32 cm  100 u.

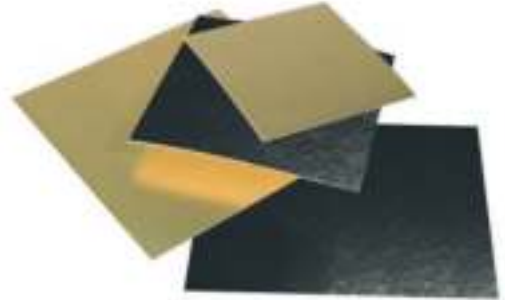

540194 30 x 40 cm  25 u.

540225 60 x 40 cm  25 u.



540090
Ø 8 cm ·  200 u.



540091
8 x 8 cm ·  200 u.



540217
9 x 5,5 cm ·  300 u.



540213
8 cm ·  300 u.

BASES REDONDAS ONDULADAS



Scalloped cake board · Bases rondes ondulées · Basi rotonde ondulate

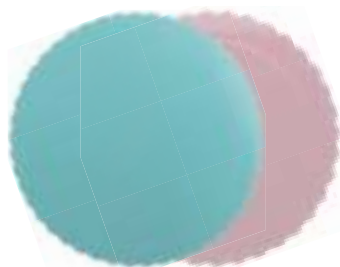

DOBLE CARA - Doble cara - Double face - Duas caras - Doppia faccia

540296 0,3 x Ø 25 cm 1 u.

540297 0,3 x Ø 30 cm 1 u.

540298 0,3 x Ø 35 cm 1 u.



NEW

PLATA - Silver - Argent - Prata
Argento

540378 0,3 x Ø 20 cm 1 u.

540379 0,3 x Ø 25 cm 1 u.

540380 0,3 x Ø 30 cm 1 u.

540381 0,3 x Ø 35 cm 1 u.



NEW

BLANCO - White - Blanc - Branco
Bianco

540374 0,3 x Ø 20 cm 1 u.

540375 0,3 x Ø 25 cm 1 u.

540376 0,3 x Ø 30 cm 1 u.

540377 0,3 x Ø 35 cm 1 u.

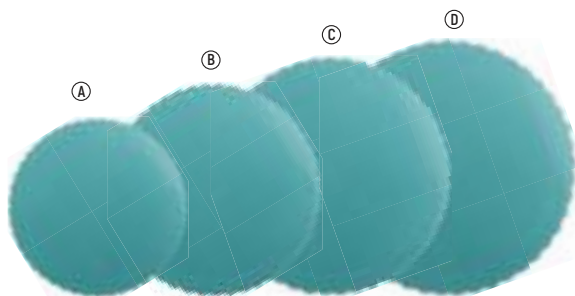

540237 0,3 x Ø 20 cm 1 u. **A**

540238 0,3 x Ø 25 cm 1 u. **B**

540239 0,3 x Ø 30 cm 1 u. **C**

540280 0,3 x Ø 35 cm 1 u. **D**

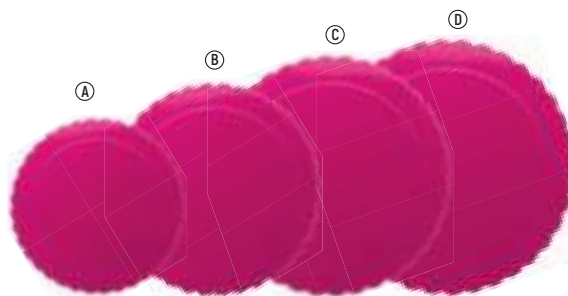

540240 0,3 x Ø 20 cm 1 u. **A**

540241 0,3 x Ø 25 cm 1 u. **B**

540242 0,3 x Ø 30 cm 1 u. **C**

540281 0,3 x Ø 35 cm 1 u. **D**

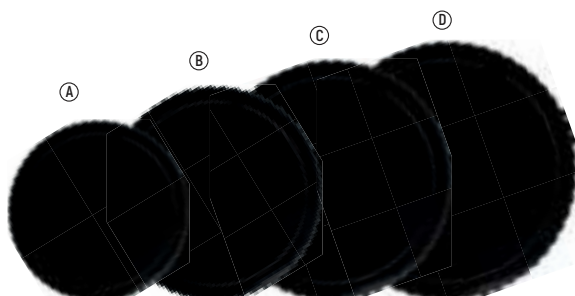

540243 0,3 x Ø 20 cm 1 u. **A**

540244 0,3 x Ø 25 cm 1 u. **B**

540245 0,3 x Ø 30 cm 1 u. **C**

540279 0,3 x Ø 35 cm 1 u. **D**

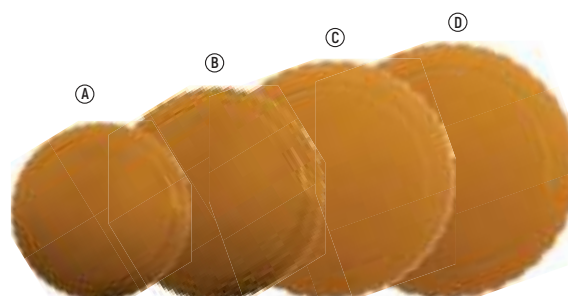

540246 0,3 x Ø 20 cm 1 u. **A**

540247 0,3 x Ø 25 cm 1 u. **B**

540249 0,3 x Ø 30 cm 1 u. **C**

540149 0,3 x Ø 35 cm 1 u. **D**



BASES CARTÓN

Cardboard plate · Assiette carton · Prato cartão · Piatto in cartone

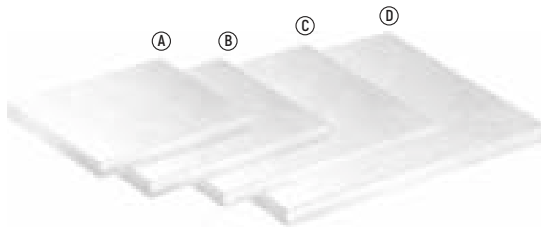

540360 25 x 25 x H: 1,2 cm **A**

540361 30 x 30 x H: 1,2 cm **B**

NEW **540362** 35,5 x 35,5 x H: 1,2 cm **C**

NEW **540363** 40 x 40 x H: 1,2 cm **D**



BLANCAS - white - blanc - branco - bianco  1 u.

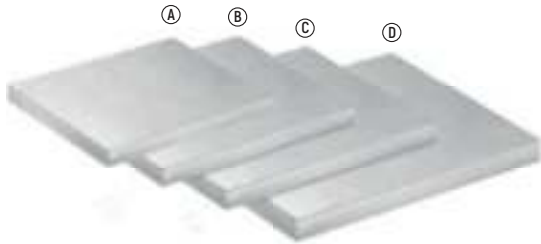

540359 25 x 25 cm x H: 1,2 cm **A**

540270 30 x 30 cm x H: 1,2 cm **B**

540075 35,5 x 35,5 cm x H: 1,2 cm **C**

540271 40 x 40 cm x H: 1,2 cm **D**



PLATA - silver - argent - prata - argento  1 u.

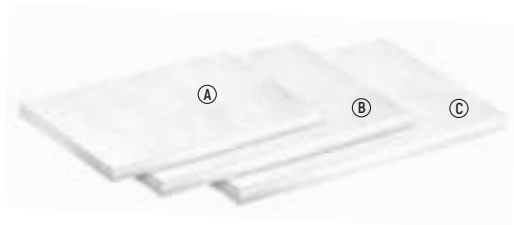

540365 20 x 30 cm x H: 1,2 cm **A**

540367 35 x 30 cm x H: 1,2 cm **B**

540370 30 x 40 cm x H: 1,2 cm **C**



BLANCAS - white - blanc - branco - bianco  1 u.

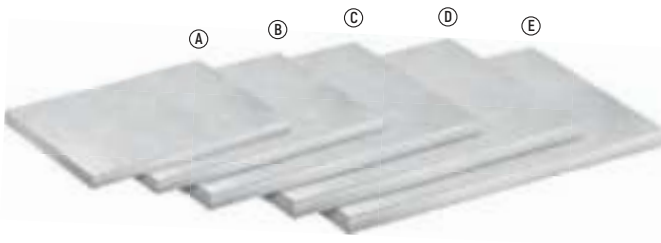

540364 20 x 30 cm x H: 1,2 cm **A**

540273 30 x 25 cm x H: 1,2 cm **B**

540272 35 x 25 cm x H: 1,2 cm **C**

540277 35 x 30 cm x H: 1,2 cm **D**

540371 30 x 40 cm x H: 1,2 cm **E**



PLATA - silver - argent - prata - argento  1 u.

BASES CARTÓN



Cardboard plate · Assiette carton · Prato cartão · Piatto in cartone



540358 Ø 20 x H: 1,2 cm **A**

540226 Ø 25 x H: 1,2 cm **B**

540229 Ø 30 x H: 1,2 cm **C**

540236 Ø 35 x H: 1,2 cm **D**

540268 Ø 40 x H: 1,2 cm **E**

540269 Ø 45 x H: 1,2 cm **F**



PLATA - silver - argent - prata - argento  1 u.



540356 Ø 20 x H: 1,2 cm **A**

540299 Ø 25 x H: 1,2 cm **B**

540304 Ø 30 x H: 1,2 cm **C**

540305 Ø 35 x H: 1,2 cm **D**

540352 Ø 40 x H: 1,2 cm **E**



BLANCAS - white - blanc - branco - bianco  1 u.



540306 Ø 25 x H: 1,2 cm **A**

540307 Ø 30 x H: 1,2 cm **B**

540308 Ø 35 x H: 1,2 cm **C**

540353 Ø 40 x H: 1,2 cm **D**



DORADAS - gold - or - oro  1 u.

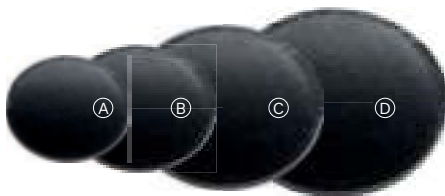

540309 Ø 25 x H: 1,2 cm **A**

540310 Ø 30 x H: 1,2 cm **B**

540311 Ø 35 x H: 1,2 cm **C**

540354 Ø 40 x H: 1,2 cm **D**



NEGRAS - black - noir - preto - nero  1 u.



PLATOS EXPOSITORES

Cake display · Plateau présentoir · Bandeja exposição · Vassoio da esposizione



■ **GIRATORIA** - Rotatory - Pivotant - Giratório
- Girevole

341124

Ø 31,5 x H: 8,5 cm ·  1 u.



■ **GIRATORIA** - Rotatory - Pivotant - Giratório
- Girevole

341155

Ø 31 x H: 3,2 cm ·  1 u.



■ **GIRATORIA** - Rotatory - Pivotant - Giratório
- Girevole

535217

Ø 32 x 10 cm ·  1 u.



■ **INCLINABLE GIRATORIA** - Rotatory tilting -
Pivotant avec inclinaison - Giratório de incli-
nação - Inclinaire girevole

535230

Ø 23 x H: 14 cm ·  1 u.



■ **TAPA DE POLIESTIRENO (PS)** - Polystyrene
lid - Couvercle en polystyrène - Tapa de
poliestireno - Coperchio in polistirolo

341154

Ø 30 x H: 11 cm

CAJAS PARA PASTERÍA SIN IMPRESIÓN BLANCAS



Pastry boxes without printing (white) · Boîtes à pâtisserie sans impression (blanche) · Caixas para pastelaria sem impressão (brancas) · Scatole per pasticceria senza stampa (bianche)













Cartón de alta resistencia apto para el contacto con alimentos; 100% fibra virgen. Cajas ideales para pastelería, bollería, venta para llevar, catering,...

EN: High-strength cardboard suitable for contact with food; 100% virgin fiber. Ideal boxes for pastries, pastries, takeaway sales, catering,.... **FR:** En carton haute résistance adapté au contact alimentaire ; 100% fibre vierges. Coffrets idéaux pour pâtisseries, viennoiseries, vente à emporter, traiteur,.... **PT:** Em cartão de alta resistência adequado ao contacto com alimentos; 100% fibra virgem. Caixas ideais para pastelaria, pastelaria, takeaway, catering,.... **IT:** In cartone ad alta resistenza idoneo al contatto con gli alimenti; 100% fibra vergine. Scatole ideali per pasticceria, pasticceria, vendita da asporto, catering,....





CUADRADA - Square - Carré - Quadrado - Quadrato

(**)

542000	4	23 x 23 x 10 cm (***)	 50 u.
542007	4	26 x 26 x 10 cm (***)	 50 u.
542008	4	29 x 29 x 10 cm (***)	 50 u.
542009	4	32 x 32 x 10 cm (***)	 50 u.
542010	4	23 x 23 x 13 cm (***)	 50 u.
542011	4	26 x 26 x 13 cm (***)	 50 u.
542012	4	32 x 32 x 13 cm (***)	 50 u.
542013	6	16 x 16 x 8 cm (*)	 50 u.
542014	6	20 x 20 x 8 cm (*)	 50 u.
542015	6	22 x 22 x 8 cm (*)	 50 u.
542016	6	25 x 25 x 8 cm (*)	 50 u.
542017	6	28 x 28 x 8 cm (*)	 50 u.

CON ASAS - With handles - Avec poignées - Com pegas - Con maniglie



542018	Fondo automático Automatic bottom	Nº 7 - 10 x 12 x 7 cm	 50 u.
542019	Fond automatique Fundo automático	Nº 10 - 10 x 18 x 7 cm	 50 u.
542020	Fondo automatico Fondo automatico	Nº 16 - 16 x 18 x 7 cm	 50 u.

(*) Forma elíptica con borde delantero más bajo para una apertura y utilización más fácil - EN: Elliptical shape with lower front edge for easier opening and use - **FR:** Forme elliptique avec bord avant inférieur pour une ouverture et une utilisation plus faciles - **PT:** Formato elíptico com borda frontal inferior para facilitar a abertura e o uso - **IT:** Forma ellittica con bordo anteriore inferiore per facilitare l'apertura e l'utilizzo

() Puntos de pegado - EN:** Gluing points - **FR:** Points de collage - **PT:** Pontos de colagem - **IT:** Punti di incollaggio



MOLDES DE POLICARBONATO PARA CHOCOLATE

Polycarbonate moulds for chocolates · Moules polycarbonate pour chocolat
Formas de policarbonato para chocolate · Stampi in policarbonato per cioccolato



NEW

525030

15 x 7,2 x 1,1 cm

1 molde x 3 u. / mould x 3 u.



NEW

525312

13,8 x 7,2 x 0,9 cm

1 molde x 3 u. / mould x 3 u.



525008

15 x 7 cm

1 molde x 3 u. / mould x 3 u.



NEW

525118

14 x 7 x 1 cm

1 molde x 3 u. / mould x 3 u.



NEW

525121

14 x 6,9 x 1,1 cm

1 molde x 3 u. / mould x 3 u.



NEW

525122

13,7 x 7,1 x 9,5 cm

1 molde x 3 u. / mould x 3 u.



525032

19,8 x 3,5 x H: 2,3 cm

1 molde x 4 u. / mould x 4 u.



525073

19,8 x 3,5 x H: 2,3 cm

1 molde x 4 u. / mould x 4 u.



525074

19,8 x 3,5 x H: 2,3 cm

1 molde x 4 u. / mould x 4 u.



525077

19,8 x 3,5 x H: 2,3 cm

1 molde x 4 u. / mould x 4 u.



525084

10 x 2,6 x H: 1,6 cm

1 molde x 8 u. / mould x 8 u.



525011

6 x 2,5 x 1,6 cm

1 molde x 18 u. / mould x 18 u.

MOLDES DE POLICARBONATO PARA CHOCOLATE



Polycarbonate moulds for chocolates · Moules polycarbonate pour chocolat
Formas de policarbonato para chocolate · Stampi in policarbonato per cioccolato



525096

7 x 6,6 cm · H: 2 cm

1 molde / mould x 6 u.



525050

3,1 x 2,7 x H: 1,4 cm

1 molde / mould x 30 u.



525065

4 x 4,2 x 1,5 cm

1 molde x 15 u. / mould x 15 u.



525038

7,5 x 7 cm · H: 2,2 cm

1 molde / mould x 6 u.



525027

4,5 x 4,2 cm · H: 1,6 cm

1 molde / mould x 12 u.



525026

3,3 x 3,3 cm · H: 1,5 cm

1 molde / mould x 24 u.



525082

3,3 x 3,3 x H: 1,5 cm

1 molde / mould x 24 u.



525083

2,5 x 2,5 x H: 1,5 cm

1 molde / mould x 30 u.



525024

4,3 x 2,6 x H: 1,6 cm

1 molde / mould x 20 u.



525173

Ø 2,8 x H: 1,8 cm

1 molde / mould x 28 u.



525080

Ø 3,7 x 3,1 x H: 1,6 cm

1 molde / mould x 28 u.



525081

3,5 x 2,3 x H: 4,6 cm

1 molde / mould x 36 u.



525197

Ø 2,7 x H: 2 cm

1 molde / mould x 30 u.



525014

Ø 3,5 x H: 1,5 cm

1 molde / mould x 24 u.



525054

9,6 x 2,2 x H: 1,7 cm

1 molde / mould x 10 u.



525029

5,2 x 2,6 x H: 1,4 cm

1 molde / mould x 21 u.



525046

Ø 2,6 x H: 2,3 cm

1 molde / mould x 28 u.



525175

2,6 x 2,6 x H: 2 cm

1 molde / mould x 30 u.



525060

Ø 3 x H: 1,5 cm

1 molde / mould x 24 u.



525003

Ø 3 cm

1 molde / mould x 28 u.



525004

3,47 x 2,2 cm

1 molde / mould x 35 u.



525334

3,3 x 2,5 x H: 1,2 cm

1 molde / mould x 24 u.



525007

2,8 x 2 x H: 1,7 cm

1 molde / mould x 28 u.



MOLDES POLICARBONATO MAGNÉTICO

Polycarbonate mould with Magnets · Moule polycarbonate avec aimants
Stampo polycarbonato con calamite



525153

16 x 7 x H: 12 cm · 3D

x 1 u.



525009

Ø 2,6 cm · 3D

1 molde / mould x 28 u.



525017

3,1 x 2,7 cm x H: 2,1 cm · 3D

1 molde / mould x 28 u.

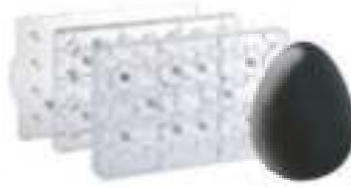

525035

2,3 x 3,2 x H: 2,3 cm · 3D

1 molde / mould x 28 u.



Molde de polycarbonato con imanes

para pralinés 3D. Ideal para ser utilizado con máquinas de dosificación automática. Compuesto por tres partes: base y tapa, equipadas con imanes, que definen la forma del praliné 3D y una placa perforada para alisar rápidamente el molde tras vaciar el exceso de chocolate.

EN: Polycarbonate mould with magnets

for 3D praline. Ideal to be used with automatic dosing machines. Composed of three parts: base and lid, equipped with magnets, which define the shape of the 3D praline and a perforated plate for quick smoothing of the mould after emptying the excess chocolate.

FR: Moule en polycarbonate avec aimants

pour pralinés 3D. idéal pour être utilisé avec des doseurs automatiques. Composé de trois parties : la base et le couvercle, équipés d'aimants, qui définissent la forme de la praline 3D et d'une plaque perforée pour un lissage rapide du moule après avoir vidé l'excès de chocolat.

PT: Molde de polycarbonato com ímanes

para pralinas 3D. Ideal para ser utilizado com máquinas doseadoras automáticas. Composto por três partes: base e tampa, equipada com imanes, que definem a forma da pralina 3D e uma placa perfurada para o alisamento rápido do molde após o esvaziamento do excesso de chocolate.

IT: Stampo in polycarbonato con calamite per

la realizzazione di praline 3D. Ideale da essere utilizzato con le macchine dosatrici automatiche. Composto da tre parti: da base e coperchio, dotate di calamite, che definiscono la forma della pralina 3D e da una placca forata per una veloce lisciatura dello stampo dopo lo svuotamento del cioccolato in eccesso.

Pralinés 3D compatibles con OneShot. Diseñados con características que los hacen aptos para su uso con máquinas dosificadoras OneShot, estos moldes de polycarbonato para pralinés permiten una alta productividad, típica de las grandes realidades artesanales e industriales.

EN: One Shot friendly 3D pralines. Designed with features that make them suitable for use with OneShot dosing machines, these polycarbonate moulds for pralines allow high productivity, typical of large artisan and industrial realities.

FR: Pralines 3D conviviales One Shot. Conçus avec des caractéristiques qui les rendent aptes à être utilisés avec les doseurs OneShot, ces moules en polycarbonate pour pralines permettent une productivité élevée, typique des grandes réalités artisanales et industrielles.

PT: Pralines One Shot 3D. Desenhadas com características que as tornam adequadas para utilização com as máquinas doseadoras OneShot, estes moldes de polycarbonato para pralinas permitem uma alta produtividade, típica das grandes realidades artesanais e industriais.

IT: Le praline 3D One Shot friendly. Studiate con caratteristiche che le rendono adatte ad essere usate dalle macchine dosatrici OneShot, questi stampi in polycarbonato per praline, consentono un'alta produttività, tipica anche delle grandi realtà artigianali ed industriali.



525034

Ø 2,6 cm x H: 2,4 cm

1 molde / mould x 28 u.

MOLDES POLICARBONATO MAGNÉTICO

Polycarbonate mould with Magnets · Moule polycarbonate avec aimants
Stampo polycarbonato con calamite



525110

Ø 15,6 x H: 22,8 cm · 3D

 1 molde / mould



525114

10 x 16 x H: 12,6 cm · 3D

 1 molde / mould



MOLDES DE POLICARBONATO PARA CHOCOLATE

Polycarbonate moulds for chocolates · Moules polycarbonate pour chocolat
Formas de policarbonato para chocolate · Stampi in policarbonato per cioccolato



525117

12 x 12 cm

 1 molde / mould

525115

6,1 x 3 cm

 1 molde / mould



* 525033	2,2 x 3,2 cm	32 pcs	7 g
* 525013	7,2 x 10,5 cm	4 pcs	70 g
* 525016	9 x 13 cm	2 pcs	150 g
* 525015	10,4 x 15 cm	2 pcs	230 g
* 525313	14,1 x 20,4 cm	1 pc	380 g
** 525311	25,8 x 17,5 cm	1 pcs	500 g



525015



CHOCOFRUIT MOLDES POLICARBONATO

Polycarbonate moulds - Moules polycarbonate - Formas policarbonato - Stampi in policarbonato



■ **MOLDE PERA 3D**
525040
 H: 3,6 cm
 Ø 2,6 cm
 1 molde / mould
 (3 bases) x 28 u.



■ **MOLDE MANZANA 3D**
525018
 H: 2,7 cm
 Ø 2,8 cm
 1 molde / mould
 (3 bases) x 28 u.

MOLDES DE PLÁSTICO TERMOFORMADO

Thermoformed plastic mould - Moule plastique thermoformé
 Stampo in plastica termoformata - Molde plástico termoformado



529075	22 x 16 x H: 8,5 cm	1 pc	1 u.
529076	15,4 x 11 x 5,5 cm	2 pcs	1 u.
525041	8 x 6 x 2,5 cm	4 pcs	1 u.



MOLDES DE PLÁSTICO TERMOFORMADO

3D thermoformed plastic mold · Moule plastique thermoformé 3D · Stampo plastica Termoformato 3D · Molde plástico termoformado 3D



■ HUEVO CURVY

Curvy egg - Oeuf curvy - Uovo curvy - Ovo curvy
Productividad 2 Huevos Completos - Productivity 2 full eggs - Productivité 2 œufs pleins - Produtividade 2 ovos inteiros - Produttività 2 uova intere.

529029

310 g · Ø 11,5 x H: 18,5 cm

Kit 5 pz. 2u. Completas.



■ **HUEVO HONEY** - Honey egg - Oeuf honey - Uovo honey - Ovo honey. Productividad 2 Huevos Completos - Productivity 2 full eggs - Productivité 2 œufs pleins - Produtividade 2 ovos inteiros - Produttività 2 uova intere.

529026

270 g · Ø 12,2 x H: 18,5 cm

Kit 5 pz. 2u. Completas.



■ **GALLINA 3D** - 3D Hen - Poule 3D - Gallina 3D - 3D galinha

529078

90 g · 10,8 x 7,5 x H: 12 cm

1 u.

■ **CONEJITO 3D** - Rabbit 3D - Lapin 3D - Coniglio 3D - Coelho.

529082

100 g · 9 x 6 x H: 15,2 cm

1 u.



■ **CONEJITO BABY 3D** - 3D bad bunny - Bebê lapin 3D - Coniglio bambino - Bebê coelho.

529077

H: 18 cm

1 u.



■ **SET 529005**

10/13/14/15/17,5/20 cm
Set 6 moldes/moulds



■ **SET 529011**

5/6,5/7,5/9 cm
Set 4 moldes/moulds



MOLDES DE PLÁSTICO TERMOFORMADO



3D thermoformed plastic mold · Moule plastique thermoformé 3D · Stampo plastica Termoformato 3D · Molde plástico termoformado 3D



529058

11,9 x 5,2 x H: 12,6 cm

 x 2 u.



529061

21 x 6,4 cm

 x 1 u.



529059

6 x 3,1 x H: 9,2 cm · 3D

 x 4 u.



529050

A: 14 x 5 x 1 cm

B: 11,7 x 3 x 1,5 cm

 x 2 u.



529051

12 x 5,2 x 1,3 cm

 x 4 u.



NEW

529032

11,5/19 x 2/5 cm

 x 4 u.





MOLDES

Moulds · Moules · Moldes · Stampo



■ **MOLDE TRONCO** - Yule log cake tin - Moule bûche - Forma tronco - Stampo tronco

535243

28 x 8,5 x 6,5 cm ·  1 u.



YouTube



■ **MOLDE CONO A. INOX**

Stainless cannoli mould
- Moule cannoli inox
- Forma cannoli inox
- Stampo cono inox

527030

Ø 3,5 x H: 14 cm ·  12 u.

527031

Ø 4 x H: 16 cm ·  12 u.



YouTube



■ **MOLDE TUBO A. INOX**

Stainless cannoli mould - Moule cannoli inox - Forma cannoli inox - Stampo cono inox

527013

2,2 x 14 cm ·  10 u.

527027

1,6 x 20 cm ·  12 u.

MOLDES DE ACERO INOX.

Stainless mould · Moule inox · Forma round inox · Stampo acciaio inox



■ KIT CAKE IDEA TRILOGY

527269

Ø 18 x H:4 cm
950 ml

Set 3 pcs

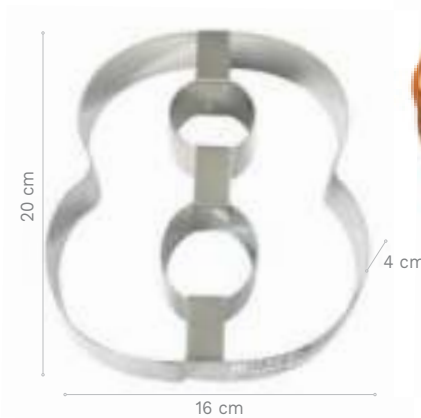

527295	20 x 16 cm	1 u.	nº 0
527286	20 x 9,3 cm	1 u.	nº 1
527287	20 x 16 cm	1 u.	nº 2
527288	20 x 16 cm	1 u.	nº 3
527289	20 x 17 cm	1 u.	nº 4
527290	20 x 16 cm	1 u.	nº 5
527291	20 x 16 cm	1 u.	nº 6
527292	20 x 16 cm	1 u.	nº 7
527293	20 x 16 cm	1 u.	nº 8
527294	20 x 16 cm	1 u.	nº 9



■ RECETA TARTA PARA MOLDE "KIT IDEA". ESCANEA ESTE CÓDIGO QR Y MIRA CÓMO HACERLO

EN: Cake recipe for mould "kit idea". Scan this qr code and see how to do it! **FR:** Recette de gâteau pour moule "kit idée". Scannez ce code qr et regardez comment le faire. **PT:** Receita bolo para forma "kit ideia". Scanea este código e olhar como fazer. **IT:** Ricetta per lo stampo "kit idea". Scansionare il codice QR per scoprire come realizzarlo





MOLDES DE ACERO INOX.

Stainless mould · Moule inox · Forma round inox · Stampo acciaio inox



NEW

■ **NEW YORK ROLL ACERO INOX**
527318

Ø 10 x H: 3,5 cm ·  1 u.



NEW

■ **TREE NEW YORK ROLL ACERO INOX**
527317

12 x 11,6 x H: 3,5 cm ·  1 u.



NEW

■ **HEART NEW YORK ROLL ACERO INOX.**
527319

10 x 10,7 x H: 3,5 cm ·  1 u.



527107

Ø 18 cm · H: 4 cm ·  1 u.

MOLDES



Moulds · Moules · Moldes · Stampo



■ **AROS PARA SEMIFRÍOS PLÁSTICO** - Semi-frozen dessert rings plastic - Anneaux en plastique pour semi-froids - Aros para semifrios plástico - Anelli per semifreddi in plastica

535248 Ø 7,5 cm x H: 5 cm 1 u.

535250 Ø 24 cm x H: 5 cm 1 u.

535253 Ø 28 cm x H: 5 cm 1 u.

MOLDES DE ACERO INOX.

Stainless mould · Moule inox · Forma round inox · Stampo acciaio inox



■ **AROS** - Rings - Anneaux - Aros - Anelli

527025 Ø 8 x H: 2 cm 1 u.

527003 Ø 14 x H: 2,5 cm 1 u.

527012 Ø 18 x H: 2,5 cm 1 u.

527016 Ø 22 x H: 2,5 cm 1 u.

527018 Ø 24 x H: 2,5 cm 1 u.

527020 Ø 18 x H: 3,5 cm 1 u.

527021 Ø 22 x H: 3,5 cm 1 u.

527022 Ø 24 x H: 3,5 cm 1 u.

NEW **527077** Ø 10 x H: 4 cm 1 u.

NEW **527076** Ø 16 x H: 4 cm 1 u.

527258 Ø 18 x H: 4 cm 1 u.

527259 Ø 20 x H: 4 cm 1 u.

527260 Ø 22 x H: 4 cm 1 u.

527261 Ø 24 x H: 4 cm 1 u.

527262 Ø 28 x H: 4 cm 1 u.

NEW **527070** Ø 16 x H: 5 cm 1 u.

NEW **527068** Ø 18 x H: 5 cm 1 u.

NEW **527069** Ø 20 x H: 5 cm 1 u.

NEW **527074** Ø 6 x H: 6 cm 1 u.

■ **CUADRADO** - Square - Carré - Square - Quadrato

527023 14 x 14 cm · H: 2,5 cm 1 u.

527024 18 x 18 cm · H: 2,5 cm 1 u.

527028 14 x 14 cm · H: 3,5 cm 1 u.

527029 18 x 18 cm · H: 3,5 cm 1 u.

527270 20 x 20 x H: 2 cm 1 u.

NEW **527067** 6 x 6 x H: 5 cm 1 u.





MOLDES DE ACERO INOX.

Stainless mould · Moule inox · Forma round inox · Stampo acciaio inox



■ **RECTANGULAR** - Rectangular - Rectangulaire - Rectangular - Rettangolare

527080 30,2 x 22,2 cm · H: 5 cm 1 u.

527081 36 x 16,5 cm · H: 5 cm 1 u.

527087 38,2 x 26,2 cm · H: 5 cm 1 u.

527088 40,3 x 30,3 cm · H: 5 cm 1 u.

527093 40,3 x 30,3 cm · H: 4 cm 1 u.

527095 30,2 x 22,2 cm · H: 4 cm 1 u.

527097 38,2 x 26,2 cm · H: 4 cm 1 u.

527106 24,3 x 14,2 cm · H: 4 cm 1 u.



■ **OVALADA** - Oval - Ovale - Oval - Ovale

527273 25,8 x 15,4 x H: 2 cm 1 u.

527274 21,6 x 11,2 x H: 2 cm 1 u.



■ **GIANDUIA**

527037 30,3 x 13,5 x H: 2 cm 1 u.

527272 23 x 6,3 x H: 2 cm 1 u.

■ **MOLDE PLÁSTICO TERMOFORMADO GIANDUIA** - Thermoformed plastic mould gianduia - Moule plastique thermoformé gianduia - Stampo in plastica termoformata gianduia - Gianduia de molde plástico termoformado.



527265 28,4 x 11,6 x H: 8 cm - 1400 ml Set 4 pcs

ENFRÍA DOS VECES MÁS RÁPIDO QUE LA SILICONA - EN: It cools 2 times faster than silicone. FR: Ça refroidit 2 fois plus vite que la silicone. PT: Arrefece duas vezes mais rápido do que o silicone. IT: Si raffredda due volte più veloce rispetto al silicone



Moulds · Moules · Moldes · Stampo

MOLDES DE MADERA PARA COCER

Wooden molds for cooking - Moules en bois pour la cuisine - Moldes de madeira para cozinhar - Stampi in legno per cuocere



540283
18,5 x 11,5 x 6 cm
☞ 100 u.



540287
25 x 11,5 x 7,5 cm
☞ 100 u.

Moldes de un solo uso, para presentaciones originales y artesanales.

EN: Single-use molds, for original and craft presentations. **FR:** Moules à usage unique, pour présentations originales et artisanales. **PT:** Moldes descartáveis, para apresentações originais e artesanais. **IT:** Stampi monouso, per presentazioni originali e artigianali.

CONDICIONES DE UTILIZACIÓN: Uso único, temperatura de utilización de -40 a 220 grados durante 30 minutos, mantener alejado de las paredes, superficies incandescentes de calor y llama, respetando un espacio entre las bandejas. Más allá de los 220 grados la naturaleza y coloración de las bandejas podría alterarse.

CONDICIONES DE STOCKAGE: Conservación 3 años a temperatura y humedad comprendida entre 20-50% en su embalaje original

EN: CONDITIONS OF USE: Single use, operating temperature from -40 to 220 degrees for 30 minutes. Keep away from walls, hot surfaces, and flames, maintaining a space between trays. Beyond 220 degrees, the nature and color of the trays may change. STORAGE CONDITIONS: Shelf life of 3 years at a temperature and humidity between 20-50% in its original packaging.

FR: CONDITIONS D'UTILISATION: Usage unique, température d'utilisation de -40 à 220 degrés pendant 30 minutes. Gardez à l'écart des murs, des surfaces chaudes et des flammes, en respectant un espace entre les plateaux. Au-delà de 220 degrés, la nature et la coloration des plateaux peuvent être altérées. CONDITIONS DE STOCKAGE: Conservation de 3 ans à une température et une humidité comprises entre 20-50% dans son emballage d'origine.

PT: CONDIÇÕES DE UTILIZAÇÃO: Uso único, temperatura de utilização de -40 a 220 graus durante 30 minutos. Mantenha afastado das paredes, superfícies incandescentes e chamas, respeitando um espaço entre as bandejas. Acima de 220 graus, a natureza e a coloração das bandejas podem alterar-se. CONDIÇÕES DE ARMAZENAMENTO: Conservação de 3 anos a uma temperatura e umidade entre 20-50% na embalagem original. **IT:** CONDIZIONI DI UTILIZZO: Uso singolo, temperatura di utilizzo da -40 a 220 gradi per 30 minuti. Tenere lontano da pareti, superfici incandescenti e fiamme, mantenendo uno spazio tra le teglie. Oltre i 220 gradi, la natura e la colorazione delle teglie potrebbero alterarsi. CONDIZIONI DI STOCCAGGIO: Conservazione di 3 anni a una temperatura e umidità compresa tra il 20-50% nella confezione originale.

PAPEL DE ALUMINIO PARA REPRESENTACIONES

Aluminium paper for presentations · Papier d'aluminium pour des représentations · Papel de alumínio para apresentações · Carta d'alluminio per rappresentazioni



455014
10 x 10 cm
Peso / Weight:
1 Kg
☞ 1.560 u.



455015
12 x 12 cm
Peso / Weight:
1 Kg
☞ 1.080 u.



455017
10 x 10 cm
Peso / Weight:
1 Kg
☞ 1.560 u.



455018
12 x 12 cm
Peso / Weight:
1 Kg
☞ 1.080 u.

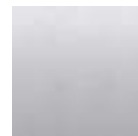

455011
10 x 10 cm
Peso / Weight:
1 Kg
☞ 1.560 u.



455012
12 x 12 cm
Peso / Weight:
1 Kg
☞ 1.080 u.



HERRAMIENTAS PARA TRABAJAR FONDANT

Fondant tools · Outils pour travail fondant · Ferramentas para trabalhar fondant · Utensile "ruota" per modellare il fondant



■ **ALISADOR PLÁSTICO** - Plastic ally - Allié plastique - Plástico aliado - Alleato di plastica

535015

 1 u.



HERRAMIENTAS PARA TRABAJAR FONDANT



Fondant tools · Outils pour travail fondant · Ferramentas para trabalhar fondant · Utensile “ruota” per modellare il fondant



■ **RODILLO PARA FONDANT** - Fondant rolling pin - Rouleau à pâte à fondant - Rolo de fondant - Rullo in fondant

535011

Ø 4,5 x 50 cm

1 u.

535014

Ø 2,5 x 23 cm

1 u.



■ SET 8 ANILLOS PARA RODILLO. PARA HACER MASA DE DIFERENTES GROSORES

- Set 8 rings assort. For roller. To make dough of different thicknesses - Jet de 8 anneaux assortis. Pour rouleau. Pour réaliser des pâtes de différentes épaisseurs - Set 8 anelli assortiti. Per rullo. Per realizzare impasti di diverso spessore - Set 8 anéis assort. Para rolo. Para fazer massa de diferentes espessuras

535016

Espesor : 4-5-6-10 mm // Ideal para rodillo 2.5 cm diam. (Ref.535014)

8 u.



• Pasta
• Pizza **4 mm**

• Cookies
• Cakes **5 mm**

• Cookies
• Pizza **6 mm**

• Donut, Croissant
• Pizza **10 mm**

■ TAPETE DE PLÁSTICO ANTIDESLIZANTE CON CÍRCULOS CONCÉNTRICOS

- Non-slip plastic mat with concentric circles - Tapis en plastique antidérapant avec cercles concentriques - Tapete plástico antiderrapante com círculos concêntricos - Tappetino in plastica antiscivolo a cerchi concentrici

535008

60 x 58 cm

1 u.

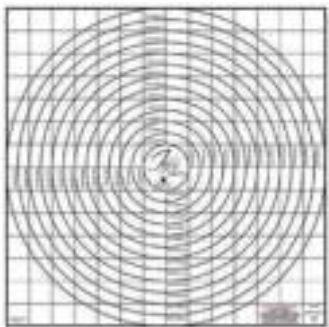

■ **UTENSILIO “RUEDA” PARA MODELAR** - Modeling wheeler tool - Ustensile forme “roue” pour moulage - Esteca roda - Utensile “ruota” per modellare

535193

15,5 cm · 1





HERRAMIENTAS PARA TRABAJAR FONDANT



Fondant tools · Outils pour travail fondant · Ferramentas para trabalhar fondant · Utensile "ruota" per modellare il fondant



■ CORTAPASTAS VOLANTE

"FORMA RECTA" - Straight shape frill cutter - Emporte pièce volant forme droite - Corta-massa babado forma de reto - Taglia pasta volante "formato dritto"

543192

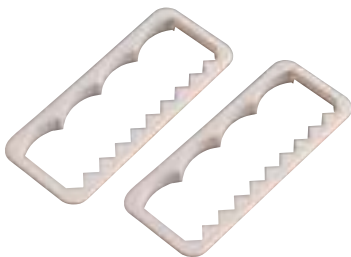

15 x 6 cm ·  1 



■ CORTAPASTAS

"VOLANTE" - Garret frill cutter - Emporte pièce volant - Corta-massa babado - Taglia pasta volante

543191



15 x 6 cm ·  1 



■ CORTAPASTAS VOLANTE

"BORDADO INGLÉS" - Broderie anglaise shape frill cutter - Emporte pièce "broderie anglaise" - Corta-massa babado "bordado inglés" - Taglia pasta volante "ricamo inglese"

543146



15 x 6 cm ·  1 



■ CORTAPASTAS "1, 3 Y 5

PÉTALOS" - 1, 3 and 5 petals cutter - Emporte pièce fleur de 1, 3 et 5 pétales - Corta-massa 1, 3 e 5 pétalas - Taglia pasta da 1, 3 e 5 petali

543190

Ø 3,2 cm ·  1 



HERRAMIENTAS PARA TRABAJAR FONDANT





Fondant tools · Outils pour travail fondant · Ferramentas para trabalhar fondant · Utensile “ruota” per modellare il fondant



■ CORTAPASTAS EXPULSOR

ESTRELLA - Star shape plunger cutter - Emporte pièce éjecteur étoile - Corta-massa ejector estrella - Taglia pasta espulsore a stella

543160

0,7 - 1 - 1,3 cm ·  1 



■ CORTAPASTAS EXPULSOR

DIAMANTE - Diamond shape plunger cutter - Emporte pièce éjecteur diamant - Corta-massa ejector diamante - Taglia pasta espulsore a diamante

543164

0,7 - 1 - 1,4 - 2,5 cm ·  1 

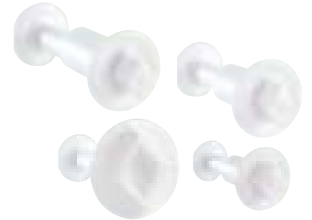

■ CORTAPASTAS EXPULSOR

ÓVALADA - Oval shape plunger cutter - Emporte pièce éjecteur ovale - Corta-massa ejector óvalo - Taglia pasta espulsore ovale

543165

0,7 - 1 - 1,4 - 2,5 cm ·  1 



■ CORTAPASTAS CÁLIZ

- Calyx flower cutter - Emporte pièce calice - Corta-massa cálice - Taglia pasta calice

543188

2,3 - 3,3 - 4 cm

 1 





TAPETES PARA SWEET LACE

Mats · Napperons · Tapetes · Tappetini per sweet lace

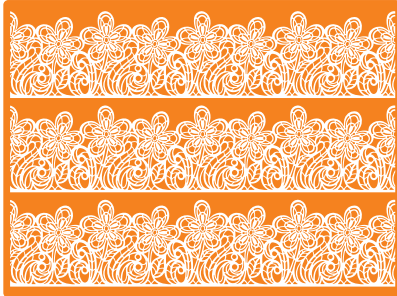

■ **FLORES** - Flowers - Fleurs
Flores - Fiori

526138

30 x 40 cm ·  1 u.

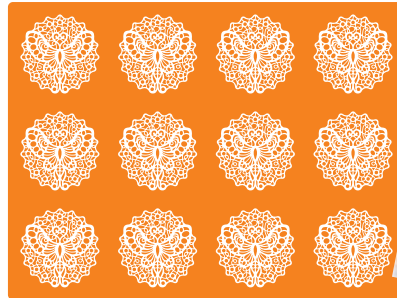

■ **MARIPOSAS** - Butterfly - Papillons -
Borboletas - Farfalle

526136

30 x 40 cm ·  1 u.

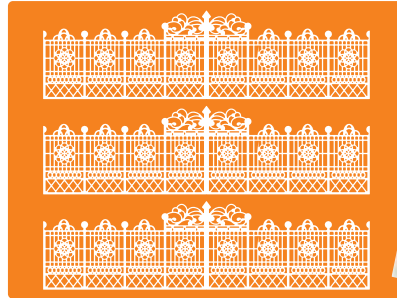

■ **CASTILLO** - Castle - Château - Castelo ·
Castello

526137

30 x 40 cm ·  1 u.



Tapetes de silicona ideales para aderezar tu postre con una decoración de azúcar muy efectiva.

Tapetes de silicona ideales para vestir tu tarta con una impresionante decoración de azúcar.

Medida - Tamaño: 30 x 40 cm -

EN: Silicone mats ideal for dressing your dessert with a highly effective sugar decoration. Silicone mats ideal to dress up your cake with an impressive sugar decoration. Measurement - Size: 30 x 40 cm. - **FR:** Tapis en silicone idéal pour habiller votre dessert d'une décoration en sucre très efficace. Tapis en silicone idéal pour habiller votre gâteau d'une impressionnante décoration en sucre. Mesure - Taille: 30 x 40 cm. - **PT:** Tapetes de silicone ideais para temperar a sua sobremesa com uma decoração de açúcar altamente eficaz. Tapetes de silicone ideais para enfeitar o seu bolo com uma impressionante decoração de açúcar. Medida - Tamanho: 30 x 40 cm. - **IT:** Tappeti in silicone ideali per vestire il tuo dolce con un decoro in zucchero di grande effetto. Silicone mats ideal to dress up your cake with an impressive sugar decoration. Misura - Size: 30 x 40cm.



FLEXIPAN®

MOLDES DE SILICONA DE ALTA TECNOLOGÍA

Solidez, duración y propiedades antiadherentes excepcionales



El Flexipan® es una combinación de fibra de vidrio y de silicona, lo que le da solidez y duración de vida inigualables, así como propiedades antiadherentes excepcionales.

El Flexipan® está autorizado por NSF® (National Safety Foundation) desde febrero de 1997. Garantiza al utilizador de nuestros productos una seguridad absoluta en cuanto a higiene y no toxicidad. Además, Demarle puede contar con la ventaja de estar admitido por la NFHSA y la FDA (Food and Drug Administration - EEUU). Todos los productos están aprobados por el LNE francés.

Todos los productos Demarle cumplen por otra parte con las legislaciones francesa, europea y norteamericana vigentes referentes a los materiales destinados al contacto con alimentos.

Consejos de utilización:

- **Relleno:** Siempre coloque su Flexipan® sobre una placa o una rejilla de cocción antes del relleno para facilitar su transporte. Rellene las formas vacías con agua.
- **Cocción:** El Flexipan® puede usarse en cualquier tipo de horno, pero sin contacto directo con la fuente de calor (por ejemplo, una llama). El tiempo y la temperatura de cocción deben estar adaptados según el horno utilizado. Es preferible utilizar una placa perforada o una rejilla con el fin de optimizar la circulación del aire caliente. Por regla general, conviene desmoldar desde la salida del horno. Para productos más delicados como Gênoises y Dacquoises, es preferible dejar enfriar antes de desmoldar.
- **Desmoldeo:** El desmoldeo se hace muy sencillamente por deformación del molde, dando la vuelta a la placa o bien para pequeñas formas levantando los bordes del Flexipan®. No use cuchillos u objetos contundentes en el Flexipan®.
- **Limpieza:** El Flexipan® se limpia fácilmente en agua caliente con una esponja suave y detergente de pH neutro. Se aconseja lavarlo muy regularmente, la acumulación de grasa resulta nefasta para la longevidad del material.
- **Almacenamiento:** Almacenar los Flexipan® por pilas de 6 como máximo.

La etiqueta NSF®

ORGANISMO CERTIFICADOR: NSF INTERNACIONAL. (Nacional Safety Foundation, organismo americano mundialmente reconocido) - 148 Avenue Grandchamps 1150 BRUXELLES (Belgique). REFERENCIA: NSF/ANSI STANDARD 2.

CARACTERÍSTICAS CERTIFICADAS: NSF/ANSI Standard 2 establece las exigencias mínimas en lo que atañe a la protección de los alimentos e higiene para los materiales, la concepción, la fabricación, la construcción y la prestación de los equipamientos vinculados con la manipulación y la preparación de los alimentos.

La marca NF Higiene alimentaria. ORGANISMO CERTIFICADOR: AFAQ AFNOR Certification, 11 Rue Francis de Pressensé 93571. LA PLAINE SAINT DENIS CEDEX - FRANCE. REFERENCIA: NF 031. CARACTERÍSTICAS CERTIFICADAS: aptitud a la limpieza. Estos productos cumplen con el reglamento 1935/2004 del Parlamento Europeo y del Consejo del 27 de octubre de 2004 refiriéndose a los materiales y objetos destinados a entrar en contacto con los productos alimenticios.

HIGH TECHNOLOGY SILICON MOULDS

Solid, long-lasting and with exceptional non-stick properties

The Flexipan® is authorized by the NSF® (National Safety Foundation) from February 1997. It guarantees the user of our products a total security with regards to hygiene and non-toxicity. Furthermore, Demarle has also the advantage to be admitted by the NFHSA and the FDA (Food and Drug Administration - USA). All of our products are approved by the French LNE.

All Demarle products comply with the current French, European and American regulations in regards to the materials intended to get into contact with food. Instructions for use:

- **Filling:** Always place your Flexipan® on a plate or cooking grate before filling it to make it easy to carry later. Fill the empty spaces with water.
- **Baking:** The Flexipan® can be used in any kind of oven but not in contact with the direct heating source (for example, a flame). The baking time and temperature must be adequate according to the oven you are using. It is recommended to use a perforated plate or a cooking grate in order to optimize the hot air flow. Normally, it is better to unmould it right after taking it out of the oven. For more delicate products like Gênoises and Dacquoises it is better to allow it to cool down a little before unmoulding.
- **Unmoulding:** It is really easy to unmould because by means of the mould deFORMStion, turning the plate or, in regards to the small forms, by lifting the edges of the Flexipan®. Do not use knives or blunt objects on the Flexipan®.
- **Cleaning:** The Flexipan® is easily cleaned in hot water with a soft sponge and pH-neutral detergent. It is recommended to wash it on a regular basis. The accumulation of fat can be detrimental for the lifespan of the product.
- **Storage:** Store the Flexipan® in stacks of 6 pieces at most.

The NSF® label

CERTIFYING BODY: NSF INTERNATIONAL (National Safety Foundation, world-wide recognised American body) - 148 Avenue Grandchamps 1150 BRUSSELS (Belgium). REFERENCE: NSF/ANSI STANDARD 2.

CERTIFIED FEATURES: NSF/ANSI Standard 2 establishes the minimum requirements with regards to the provision of equipment intended for the preparation and handling of food.

The NF food hygiene label. CERTIFYING BODY: AFAQ AFNOR Certification, 11 Rue Francis de Pressensé 93571. LA PLAINE SAINT DENIS CEDEX - FRANCE. REFERENCE: NF 031.

CERTIFIED FEATURES: Cleaning suitability. These products comply with the regulations 1935/2004 of the European Parliament and the Council of 27 September 2004 with regards to the materials and objects intended to get into contact with food.

■ TUTORIAL MOLDE RECETA FLEXIPAN®

EN: Flexipan® mould recipe. FR: Recette pour moule en Flexipan®

PT: Receita forma Flexipan® IT: Tutorial ricetta stampo Flexipan®





MOLDES FLEXIPAN

Moulds · Moules · Moldes · Stampo



■ FLEXIPAN 528116

PLACA Plates	MEDIDAS Size	FORMAS Forms
60 x 40 cm	7,8 x 4,7 x H: 1,9 cm	40



■ FLEXIPAN 528143

PLACA Plates	MEDIDAS Size	FORMAS Forms
60 x 40 cm	9,5 x 4 x H: 3 cm	24



■ SEMI ESFERAS 528050

PLACA Plates	MEDIDAS Size	FORMAS Forms
60 x 40 cm	Ø 7 x H: 4 cm	24



■ FLEXIPAN 528149

PLACA Plates	MEDIDAS Size	FORMAS Forms
60 x 40 cm	Ø 10 x H: 3,5 cm	12



■ CAMPANA 528557

PLACA Plates	MEDIDAS Size	FORMAS Forms
60 x 40 cm	10,2 x 9,2 x H: 2,9 cm	15



■ PETITS FOURS 528031

PLACA Plates	MEDIDAS Size	FORMAS Forms
60 x 40 cm	Ø 4 x H: 2 cm	4



MOLDES FLEXIPAN

Moulds · Moules · Moldes · Stampo



■ **FLEXIPAN**
528082

MEDIDAS	FORMAS
Size	Forms
33,5 x 13 cm	1



■ **FLEXIPAN**
528021

MEDIDAS	FORMAS
Size	Forms
32 x 18 x H: 3,5 cm	1



■ **FLEXIPAN**
528033

PLACA	MEDIDAS	FORMAS
Plates	Size	Forms
60 x 40 cm	Ø 18 x H: 5 cm	6



■ **FLEXIPAN**
528053

PLACA	MEDIDAS	FORMAS
Plates	Size	Forms
40 x 30 cm	9,3 x 6 x H: 4 cm	8



■ **FLEXIPAN**
528013

PLACA	MEDIDAS
Plates	Size
60 x 40 cm	Ø 7,3 cm

FORMAS
Forms
24



MOLDES FLEXIPAN

Moulds · Moules · Moldes · Stampo



528477

MEDIDAS

Size

22 x 22 x H: 4,5 cm

FORMAS

Forms

1



528255

MEDIDAS

Size

57,5 x 37,5 x H: 5 cm

FORMAS

Forms

1



528369

MEDIDAS

Size

Ø 22 x H: 4,5 cm

FORMAS

Forms

1



528486

PLACA

Plates

60 x 40 cm

MEDIDAS

Size

Ø 7 x H: 4 cm

FORMAS

Forms

24



528240

PLACA
Plates

60 x 40 cm

MEDIDAS

Size

7,5 x 6,5 x H: 3,5 cm

FORMAS

Forms

20



528080

PLACA
Plates

60 x 40 cm

MEDIDAS

Size

6,6 x 6,2 x H: 3,5 cm

FORMAS

Forms

20

MOLDES FLEXIPAN

Moulds · Moules · Moldes · Stampo



NEW

528086

PLACA	MEDIDAS	FORMAS
Plates	Size	Forms
40 x 30 cm	6,5 x 3,6 x H: 2,7 cm	30



NEW

528006

PLACA	MEDIDAS	FORMAS
Plates	Size	Forms
60 x 40 cm	7,9 x H: 1,5 cm	24



528504

PLACA	MEDIDAS	FORMAS
Plates	Size	Forms
60 x 40 cm	Ø 7,9 x H: 4 cm	24



528505

PLACA	MEDIDAS	FORMAS
Plates	Size	Forms
30 x 20 cm	Ø 4,5 x H: 4,85 cm	8



528495

PLACA	MEDIDAS	FORMAS
Plates	Size	Forms
60 x 40 cm	7 x 7 x H: 3,4 cm	24



MOLDES DE SILICONA

Silicone moulds · Moules en silicone · Moldes de silicone
Stampo in silicone



■ MINI MUFFINS 528475

PLACA / Plates 60 x 40 cm
MEDIDAS / Size Ø 5 x H: 2,8 cm
FORMAS / Forms 54
Vol. 40 ml



■ MUFFINS 528473

PLACA / Plates 60 x 40 cm
MEDIDAS / Size Ø 6,9 x H: 3,9 cm
FORMAS / Forms 24
Vol. 120 ml



■ DONUTS 528467

PLACA / Plates 60 x 40 cm
MEDIDAS / Size Ø 7,5 x H: 2,5 cm
FORMAS / Forms 24
Vol. 90 ml



■ CORAZÓN 528468

PLACA / Plates 60 x 40 cm
MEDIDAS / Size 7,5 x 6,8 x H: 3 cm
FORMAS / Forms 24
Vol. 90 ml



■ ECLAIR 528469

PLACA / Plates 60 x 40 cm
MEDIDAS / Size 13 x 3 x H: 2,8 cm
FORMAS / Forms 28
Vol. 85 ml



■ MADELEINE 528470

PLACA / Plates 60 x 40 cm
MEDIDAS / Size 7,4 x 4,5 x H: 1,8 cm
FORMAS / Forms 44
Vol. 35 ml



■ ESFERA 528474

PLACA / Plates 60 x 40 cm
MEDIDAS / Size Ø 7 x H: 3,5 cm
FORMAS / Forms 20
Vol. 90 ml



■ MINI ESFERA 528476

PLACA / Plates 60 x 40 cm
MEDIDAS / Size Ø 3,5 x H: 1,75 cm
FORMAS / Forms 96
Vol. 10 ml

MOLDES DE SILICONA



Silicone moulds · Moules en silicone · Moldes de silicone
Stampo in silicone



528215

Ø 4 x 2 cm

1 u. 15 formas / forms



528201

Ø 4 x 2 cm

1 u. 15 formas / forms



528202

Ø 7 x 3,5 cm

1 u. 15 formas / forms



528515

7,9 x 2,9 x H: 3 cm

1 u. 12 formas / forms



528350

Ø 7,9 x 3,7 cm

1 u. 6 formas / forms



528353

Ø 6,8 x 3,8 cm

1 u. 6 formas / forms



528361

Ø 7,5 x 2,5 cm

1 u. 6 formas / forms



528008

Ø 3 x H: 1,5 cm

1 u. 24 formas / forms



528010

Ø 6 x H: 3 cm

1 u. 6 formas / forms



528203

Ø 8 x H: 4 cm

1 u. 5 formas / forms



528426

Ø 6,8 x 4,5 x H: 1,7 cm

1 u. 9 formas / forms



528200

Ø 3,4 x 1,6 cm

1 u. 24 formas / forms



528137

Ø 6,5 x 2,1 cm

1 u. 8 formas / forms



MOLDES

Moulds · Moules · Moldes · Stampo

SILICONFLEX Y UNIFLEX

Siliconflex and Uniflex moulds - Siliconflex et Uniflex moules - Formas Siliconflex e Uniflex

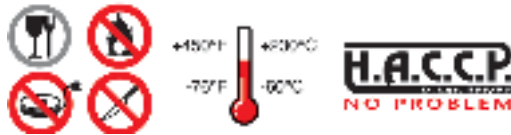
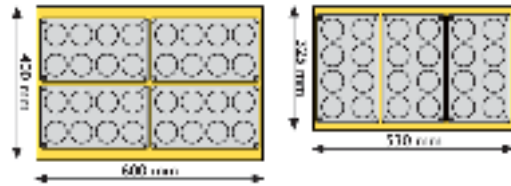

- Los moldes SILICONFLEX y UNIFLEX son aptos tanto para la cocción en horno como para la congelación.
- Especiales para postres, salados, chocolate y tarrinas.
- Óptimo para acaramelado del sirope.
- Preparación y decoración directamente sobre el molde.
- Ahorro en operaciones de engrase de los moldes.
- Se lava simplemente con agua caliente, con una esponja o en el lavavajillas.
- Medidas de las placas: 17,5 x 30 cm

- EN: The SILICONFLEX and UNIFLEX moulds are suitable for both baking and freezing.
- Well suited for desserts, savoury products, chocolate and terrines.
 - Optimal for caramelized syrup.
 - Preparation and decoration directly on the mould.
 - Saving in operations of lubrication of the moulds.
 - It is simply washed with hot water, with a sponge or in the dishwasher.
 - Size of the plates: 17,5 x 30 cm



528184

Ø 28 x 4,7 cm · 1 u.



528187

26 x 10 x H: 70 cm · 1 u.,



■ **MACARONS**

526094

60 x 40 · Ø 4 cm

1 u. 70 formas / forms

■ **MACARONS**

526149

30 x 40 · Ø 4 cm

1 u. 34 formas / forms



■ **ECLAIR**

526143

30 x 40 · 2,5 x 12,5 cm

1 u. 18 formas / forms



■ **ECLAIR** - Cookie cutter inox. - Coupe-pâtes inox. - Cortapastas inox. - Affetta torte inox.

543235

2,5 x 12,5 cm · 1 u.



■ **MINI ECLAIR**

526148

30 x 40 · 1,8 x 6 cm

1 u. 35 formas / forms



■ **MINI ECLAIR** -

Cookie cutter inox. - Coupe-pâtes inox. - Cortapastas inox. - Affetta torte inox.

543236

1,8 x 6 cm · 1 u.

BANDAS DE SILICONA





Silicone cake ring - Bande silicone - Faixas de silicone - Fascia in silicone



■ **BANDA SILICONA PERFORADA** - Silicone cake ring micro bands - Bande silicone perforée - Fascia perforata in silicone

526050 50 cm · H: 2,5 cm  10 u.

526055 75 cm · H: 2,5 cm  10 u.

526070 62,5 cm · H: 3,5 cm  10 u.

526073 75 cm · H: 3,5 cm  10 u.

REDUCCIÓN DEL TIEMPO DE PRODUCCIÓN

Alrededor del 30% simplificando los pasos.

CERO IMPERFECCIONES

Porque permite que la humedad escape.

RÁPIDO DESMOLDE SIN ROTURAS

Permitiendo desmoldar tanto en caliente como en frío.

REDUCCIÓN DE COSTES

Al alcanzar el 99% de éxito en la producción con menos gastos.



EN: REDUCTION OF PRODUCTION TIMES by simplifying the steps and reducing times by around 30% EVEN COOKING WITH ZERO IMPERFECTIONS because they allow moisture to escape QUICK UNMOULDING WITHOUT BREAKINGS by allowing the un moulding of both hot and cold products WASTE AND COST REDUCTION you will be 99% successful in production with less wasting

FR: UNE RÉDUCTION DES TEMPS DE PRODUCTION grâce à la simplification des étapes et à une réduction des délais d'environ 30 % VOS PÂTISSERIES SANS AUCUNE IMPERFECTION, grâce à l'évacuation de l'humidité UN DÉMOULAGE RAPIDE ET SANS CASSURES, grâce au démoulage des pâtisseries à chaud et à froid UNE RÉDUCTION DES DÉCHETS ET DES COÛTS, vos productions réussies à 99 % et avec moins de déchets

PT: REDUÇÃO DOS TEMPOS DE PRODUÇÃO, simplificando os passos e reduzindo os tempos em cerca de 30% COZINHANDO COM ZERO IMPERFEIÇÕES porque permitem que a humidade saia DESMONTAGEM RÁPIDA SEM PARTIR, permitindo a desmoldagem de produtos quentes e frios REDUÇÃO DE RESÍDUOS E CUSTOS, terá 99% de sucesso na produção com menos desperdício

IT: RIDUCI IL TEMPO DI PRODUZIONE di circa il 30% semplificando i passaggi. ZERO IMPERFEZIONI grazie alla funzione di fuoriuscita dell'umidità. SFORMATURA RAPIDA SENZA ROTTURA sia a caldo che a freddo. RIDUCI I COSTI, grazie a un tasso di successo del 99% della produzione, per meno spese.



 YouTube





LA POLIVALENCIA EN EL OBRADOR

Entre -40 °C y +300 °C

Reemplaza a los papeles de silicona
Evita el humo y la carbonización de las grasas

¿QUÉ ES EL SILPAT?

SILPAT es una hoja de caucho siliconado alimenticio, reforzado por una tela a base de "silicone"; está destinado a la cocción sobre bandejas y latas para hornear cualquier tipo de masa, aunque su uso es múltiple, ya que mantiene su antiadherencia a temperaturas negativas -40° C y positivas +300°C.

FACILIDAD DE EMPLEO Y DURACIÓN

SILPAT suprime el engrasado de las bandejas y latas, su limpieza evita el humo provocado por la cocción o la carbonización de las grasas; solución radical en aquellos productos cuya absorción de grasas adultera el sabor y la presentación del mismo. Reemplaza los papeles de silicona. Su almacenaje ocupa poco espacio. Permite poderlo utilizar nuevamente una vez limpio (entre 500 - 2.000 veces, según la naturaleza de la masa). Se interpone entre la lata y el producto, evitando, al cocer un producto, que éste adquiera los puntos negros producidos por la carbonización de los residuos de otros productos cocidos anteriormente. Limpieza con agua caliente o utilizando papel.

SUS ENEMIGOS

- No aplicar fuego directo.
- Almacenarlos en plano, nunca doblarlos.
- Las rasquetas de acero, cuchillos y pliegues que se forman si se doblan, pueden rasgarlos.
- Lavarlos con detergentes va deteriorando su garantía de antiadherencia.

THE BAKING VERSATILITY

Between -40 °C and +300 °C

It replaces the silicon papers
It avoids the smoke and the fat carbonisation

WHAT IS SILPAT?

SILPAT is a silicone rubber sheet suitable for food contact. Reinforced with a silicone fabric, it is intended for baking any kind of pastry on trays and cans. Bu it also has multiple uses since its non-stick properties remain with negative (-40°C) and positive temperatures (+300°C).

EASY TO USE AND DURABILITY





SILPAT suppresses the lubrication of trays and cans. It is clean, avoiding the smoke coming from cooking and fat carbonisation; a radical solution for those products which absorb fat and thus change their flavour and presentation. It replaces the silicon papers. Its storage does not require much space. It can be used again and again once it is clean (between 500 and 2000 times depending on the nature of the dough). It stands between the tray and the product, thus avoiding the black spots which appear due to the carbonisation of the residues from other products that have been baked previously. You can clean it with hot water or using paper.

ITS ENEMIES

- Do not use with direct fire.
- Store them on a flat level, never fold them.
- If they are folded, the steel scrapers, blades and folds can tear them.
- To wash them with detergents can deteriorate their non-stick guarantee.

SILPAT®



528300	40 x 30 cm	 1 u.
528001	60 x 40 cm	 1 u.
528007	53 x 32,5 cm	 1 u.
528003	75 x 45 cm	 1 u.

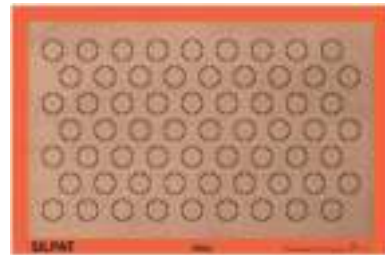

■ **SILPAT ESPECIAL MACARONS** - Special product for macarons - Produit spécial pour macarons - Produto especial para macarons

528126

PLACA / Plates	MEDIDAS / Size	FORMAS / Forms
60 x 40 cm	Ø 3,5 cm	63



ESPECIAL MACARONS

■ **FLEXIPAN** - Special for macarons - Spécial pour macarons - Especial para macarons - Specifico per macarons

528159

PLACA / Plates	MEDIDAS / Size	FORMAS / Forms
60 x 40 cm	Ø 3,8 x H: 0,3 cm	77



FLEXIPAT®

- El Flexipat® permite, gracias a sus bordes, alisar o rellenar muy rápidamente cualquier tipo de preparaciones con un espesor siempre igual. Así las cocciones y congelaciones son siempre regulares.
- Permite también ganar en productividad limitando pérdidas de productos cuando se monta el postre en el marco.

EN: Thanks to its edges Flexipan® allows you to stretch or fill any kind of preparation really fast with always the same identical thickness. Thus, whether you bake it or freeze it, it will be regular.

- It also allows you to increase productivity and limit losses of products when the dessert is mounted on the frame.



528000

55,5 x 36 x H: 1 cm ·  1 u..

SILPAIN®

ESTERAS PARA PANADERÍA

Entre -40 °C y +240 °C

Fermentación/ horneado/ congelado

El Silpain® es una esterilla antiadherente que es especialmente adecuada para hornear panes especiales o productos con masa crujiente (por ejemplo, pancakes crujientes o panecillos) Malla realizada en fibra de vidrio, con recubrimiento de silicona. Hay pequeñas perforaciones en la esterilla para una mejor transferencia de calor y una mejor corteza.

BAKINGS MATS

Between -40 °C and +240 °C

Fermentation/ baking/ freezing

A non-stick mat which is particularly suitable for baking special breads or product with crusty dough (e.g buckwheat pancakes or bread rolls)

Mesh made from fiberglass, with silicone coating.

There are small perforation in the mat for better transfer of heat and improved crustiness.

528458

60 x 40 cm ·  1 u.



■ TAPETE PERFORADO SILICONA -

Perforated silicone banking sheet
- Tapis silicone perforé - Tovaglietta perforata in silicone

526074 40 x 30 cm  1 u.

526072 60 x 40 cm  1 u.



40 cm

30 cm

■ PAPEL SILICONADO PARA HORNEAR

Silicone oven paper - Papier silicone pour enfourner - Papel de silicone para ornear - Carta siliconata

520001

59 x 39 cm ·  1 u.





UTILLAJE

Tools · Outillage · Utensílios · Utensili



■ DOSIFICADOR AUTOMÁTICO ACERO

& SOPORTE - Automatic dispenser. Steel & support - Doseur automatique acire & support - Dosificador automático aço & suporte - Dosatore automatico acciaio e supporto

DOSIFICADOR / Dispenser

SOPORTE / Support

535007

Ø 18,5 cm

1,9 L. ·  1 u.

535285

H: 18,5 cm

 1 u.





■ **FUENTE DE CHOCOLATE BASE INOX.** - Dish for chocolate stainless base. - Fontaine chocolat base acier inox. - Fonte de chocolate base inox. - Fontane di cioccolato base inox.

535001

Ø 39 x H: 80 cm
 Capacidad / Capacity: 5 Kg
 Tensión / Voltage: 220 - 249 V / 50 Hz.
 Stampi in policarbonato  1 u.

NUOVO BOL - NEW BOWL - NOUVEAU BOL - NOVA TAÇA - NUOVA CIOTOLA

La forma del nuevo bowl de acero inoxidable evita que el chocolate se desborde al desmontarlo y limpiarlo.

EN: The shape of the new stainless-steel bowl prevents the chocolate from overflowing on disassembly and cleaning. **FR:** La forme du nouveau bol en acier inoxydable empêche le chocolat de déborder sur le démontage et le nettoyage. **PT:** A forma da nova taça em aço inoxidável impede que o chocolate transborde ao desmontar ou limpar. **IT:** La forma di questa nuova ciotola in acciaio inossidabile permette di evitare che il cioccolato fuoriesca in fase di smontaggio e pulizia.



■ **FUENTE DE CHOCOLATE PEQUEÑA BASE INOX.**

- Small dish for chocolate stainless base. - Fontaine chocolat petit base acier inox. - Fonte de chocolate pequena base inox. - Fontane di cioccolato piccola base inox.

535730

Ø 21 x H: 42 cm
 Capacidad / Capacity: 1,5 Kg
 Potencia / Power: 70 W.
 Tensión / Voltage: 230 V / 50 Hz.

 1 u.

■ **SET DE UTENSILIOS PARA CHOCOLATE DE ACERO INOX. CON MANGO DE PLÁSTICO**

Set of stainless steel tools for chocolate with plastic handle - Set d'outils pour chocolat en acier inoxydable avec poignée en plastique - Set de ferramentas para chocolate de acero inox. com cabo de plástico - Set di utensili per cioccolato in acciaio inox con manico in plastica

535395

18 cm ·  x 10 utensilios / tools.





UTILLAJE

Tools · Outillage · Utensílios · Utensili



■ BASE GIRATORIA ELÉCTRICA -

Spinner electric cake turntable
- Spinner électrique rotary - Base
girevole elettrica

341015

27 x 26 x H: 12 cm

1 u.



Regulador de velocidad. Plato con escala graduada de 6 a 22 cm. Anillo conductor circular. Luz led que varía según la velocidad. Plato de plexiglass. Rotación a un lado y al otro.

EN: Speed regulator. Graduated plate between 2,36 and 8,66 inch. Roller ring support. LED brightness is proportional to the rotation speed. Plexiglass plate. Clockwise and anti-clockwise rotation. **FR:** Régulateur de vitesse. Plateau gradué entre 2,36 et 8,66 pouces. Support sous la forme d'un anneau à roulettes. Luminosité LED proportionnelle à la vitesse de rotation. Plateau en plexiglass. Rotation dans les deux sens. **PT:** Regulador de velocidade. Placa com escala graduada de 6 a 22 cm. Anel condutor circular. Luz LED que varia consoante a velocidade. Placa de plexiglass. Rotação para um lado e para o outro lado. **IT:** Regolatore di velocità. Piatto con scala graduata da 6 a 22 cm. Anello conduttore circolare. Luce LED che varia a seconda della velocità. Piatto in plexiglas. Rotazione da un lato all'altro

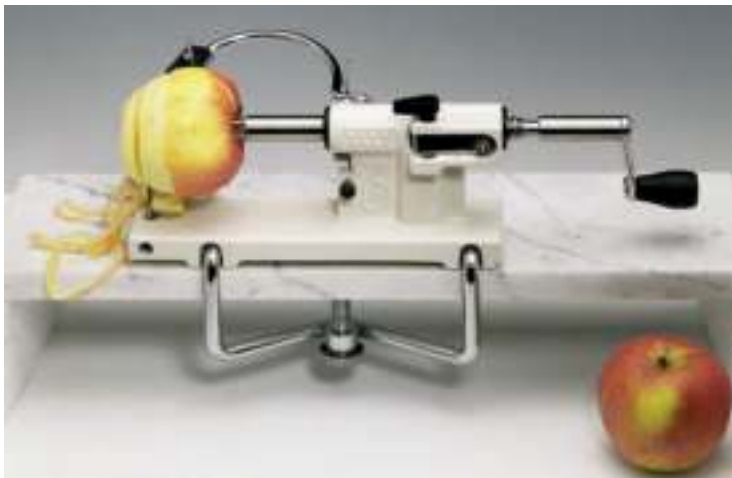

■ PELAMANZANAS "KALI" 3 USOS, CON POSIBILIDAD DE DESMONTAR - "Kali" apple peeler 3 uses. Detachable - Pele-pommes de terre "kali" 3 uses, avec possibilité d'être démonter - Pela maças "kali" 3 usos, com possibilidade de desmontar - Sbucciamele a 2 utilizzi con possibilità di smontare

535231

10 x 34 x H: 11 cm · Peso / Weight: 2,5 Kg · 1 u.



■ **MINI MELTIN CHOC ROJO**

Analógico / Analog

Dimensiones / Dimensions : 26 x 26 H: 16 cm

Capacidad / Capacity : 1.8L

60W – 230V

Peso / Weight: 1.5 kg

623001



■ **FUNDIDOR EN SECO DISEÑADO PARA HELADERÍAS** - Deep meltin choc

Analógico / Analog

Cubeta Extraible de Aluminio

Dimensiones / Dimensions : Ø 20,5 x H: 21 cm

Capacidad / Capacity: 1.7L

50W / 230V

623002



■ **ATEMPERADOR CHOCOLATE ANALÓGICO CUBETA (3.5 l)** - Chocolate tempering machine - Tempérer le chocolat - Temperador de chocolate atemperatore cioccolato

Analógico / Analog

Deposito Extraible de A.Inox / Stainless Steel Removal deposit

Dimensiones / Dimensions : 24 x 40 h 13,5 cm

Capacidad / Capacity : 3.6L

50W 230V

Peso / Weight: 2.7Kg

623000



■ **ATEMPERADOR DE CHOCOLATE** - Chocolate tempering machine - Tempérer le chocolat - Temperador de chocolate atemperatore cioccolato

Cubeta Extraible / Mobile cover

Tapa A Inox. / Stainless Steel Cover

Dimensiones / Dimensions : Ø 51 x H: 40 x 26.5 cm

Capacidad / Capacity : 12 Litros (10kg Cobertura)

1000W 220-240V

Monofásico/ Monophasic

Peso / Weight: 5.5kg

★ **623004**



■ **CALORIBAC. MANTENEDOR DE TEMPERATURA**

- Maintains temperature - Mainteneur de température - Mantenedor de temperatura. - Strumento di mantenimento temperatura

Cuba de Acero Inox. no extraible / Non removable stainless steel tank

Tapa transparente / Transparent cover

Dimensiones / Dimensions : Ø 25,4 x 18,8 cm

Capacidad / Capacity: 3,5 litros.

200 W. · 240 V.

Monofásico / Monophasic

Peso / Weight: 1,8 Kg

623006



UTILLAJE

Tools · Outillage · Utensílios · Utensili

CAJAS ISOTÉRMICAS ECOLINE

Ecoline isothermal boxes - Boîtes isothermes ecoline
Caixas isotérmicas ecoline - Scatole isothermiche ecoline

Versiones básicas de los artículos. EN: Alternative for starters. Basic versions of the articles

Material EPP. Resistentes y ligeras. Alta capacidad aislante. A prueba de lavavajillas, higiénicas. EN: EPP material. Strong and lightweight. High insulating capacity. Dishwasher-proof, hygienic. **FR:** Matériau EPP. Solide et léger. Grande capacité d'isolation. Résistant au lave-vaisselle, hygiénique. **PT:** Material EPP. Forte e leve. Elevada capacidade de isolamento. Resistente à máquina de lavar louça, higiénico. **IT:** Materiale EPP. Resistente e leggero. Elevata capacità isolante. Lavabile in lavastoviglie, igienico.



■ CAJA GN 1/1 ECO LINE

Box - Case - Caixa - Scatola

501042	24	30,5	45	720

Interior / inside: 54,6 x 34,6 cm - **Exterior / outside:** 60 x 40 cm



■ CAJA UNIVERSAL ECO LINE

Box - Case - Caixa - Scatola

501041	30	36	80	1.020

Interior / inside: 63 x 43 cm - **Exterior / outside:** 68,5 x 48,5 cm



■ CAJA PIZZA ECO LINE

Box - Case - Caixa - Scatola

501040	17,5	23,5	21,5	650

Interior / inside: 35 x 35 cm - **Exterior / outside:** 41 x 41 cm

La gama Eco Line se caracteriza por ser una versión básica con las características más importantes, que representa una sólida caja de transporte y aislamiento. EN: The Eco Line range is characterised by a basic version with the most important features, which represents a solid transport and insulation box. **FR:** La gamme Eco Line se caractérise par une version de base dotée des caractéristiques les plus importantes, qui constitue une solide caisse de transport et d'isolation. **PT:** A gama Eco Line caracteriza-se por uma versão de base com as características mais importantes, que representa uma caixa de transporte e de isolamento sólida. **IT:** La gamma Eco Line è caratterizzata da una versione base con le caratteristiche più importanti, che rappresenta un solido box di trasporto e isolamento



CAJAS ISOTÉRMICAS

Isothermic boxes - Boîtes isothermes - Caixas Isotérmicas - Scatole isothermiche

- A prueba de roturas (EPP, no es corcho)
- Robustas, ligeras y duraderas
- Alta capacidad aislante
- Utilizable de -40 a +120° C
- A prueba de lavavajillas, higiénicas
- Cumple estándar HACCP

- Damage proof (EPP, it is not cardboard)
- Hard, light and durable.
- High isolation capacity.
- Suitable from -40°C up to +120°C
- Dishwasher proof, hygienic.
- It complies with the HACCP standard

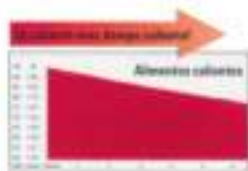
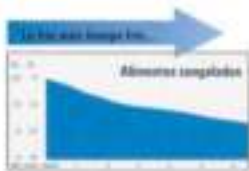

■ CAJA GN 1/1 CONFORT

Box - Case - Caixa - Scatola

501087	25	33	46	1.400

Interior / inside: 54 x 34 cm - Exterior / outside: 67 x 40 cm

■ CAJA MULTIUNIVERSAL SIN TAPA

Multi universal box with no cover - Boîte sans couvercle multiuniversel - Caixa multiuniversal sem tampa - Scatola multiuniversale senza coperchio

501011	8	12,5	21,5	700
501012	12	16,5	32	800
501014				
Tapa de recambio		3		305

Replacement cover

Interior / inside: 62,5 x 42,5 cm - Exterior / outside: 68,5 x 48,5 cm



■ CAJA UNISTAR

Unistar box - Case Unistar - Caixa Unistar - Scatola Unistar

501006	12	18,5	33	1.270
501007	16	22	44	1.300
501010	30	36	82	1.900

Para transporte de tartas, pasteles y pastas congeladas. Con tapa. Bandejas 60 x 40 cm Interior: 63,5 x 43,5 cm / exterior: 69,5 x 49,5 cm

To transport cakes, pies and frozen dough. With cover. Tray 60 x 40 cm
Inside: 63,5 x 43,5 cm / outside: 69,5 x 49,5 cm



Superficie interior impermeable. Fácil carga y descarga gracias al hueco. Espacio en los lados largos y en las esquinas. Superficie exterior de la más alta calidad. Mangos ergonómicos. Tapa de fácil apertura desde las esquinas. Etiquetas rígidas o flexibles para la identificación del producto.

Waterproof inside surface. Easy loading and unloading due to the recessed space on the long sides and on the corners. Highest quality outer surface. Ergonomic handles. Easy opening lid from the corners. Rigid or flexible labels for product identification.



UTILLAJE

Tools · Outillage · Utensílios · Utensili



■ CAJA COMBI JUNIOR UNIVERSAL LATERAL

Universal junior combi side box

				
501000	32,5	40,5	45,5	2.300

Interior / Inside: 60,5 x 40,5 cm - **Exterior / Outside:** 68 x 49 cm

Caja de carga frontal. Conveniente para cargar y descargar, Perfecta para bandejas. 3 carriles y 8,1 cm. Termómetro integrado para el control continuo de la temperatura.

Front load box. Convenient to load/unload; perfect for trays. 3 slides: each with distance of approx 8,1 cm Integrated thermometer for ongoing temperature control.







■ CAJA COMBI UNIVERSAL PARA BANDEJAS DE 60 x 40 cm y 40 x 30 cm

Universal combi box for trays 60 x 40 cm and 40 x 30 cm

Combi universal box plateau 60 X 40 cm Et 40 x 30 cm

Caixa combi universal para bandejas de 60 x 40 cm y 40 x 30 cm

Scatola combinata universale per vassoio

				
501064	51	62	125	6.500

Interior / Inside: 62 x 40,5 cm - **Exterior / Outside:** 70 x 58 cm

Guías / Guides: 5/3



■ ACCESORIOS

Accessories - Accessoires - Accesorios - Accessori

501093



2 partes laterales guías 9/1 - 2 side pieces guides 9/1



■ THERMO SOPORTE MÓVIL PARA CAJA GN 1/1

Thermo mobile support - Thermo support mobile - Thermo

sopORTE móvil - Thermo supporto mobile per scatola

			
501067	60 x 40 x 16	2.700	250

NPE, 4 ruedas, muy estable

NPE, 4 wheels. Very stable.

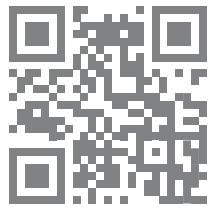

dekora.es



Dekora Innova S.A.U.
Pol. Ind. Las Atalayas • c/Florín, Parcela 30-39
Buzón 20095 • 03114 Alicante (Spain)
Tel. (+34) 965 94 30 33

www.dekora.es



[company/dekora/](https://www.linkedin.com/company/dekora/)



[dekorainnova](https://www.pinterest.com/dekorainnova)



[/dekorainnova](https://www.youtube.com/channel/UCdekorainnova)



[/dekorainnova](https://www.tiktok.com/@dekorainnova)